

TECHNICAL MANUAL
UNIT
MAINTENANCE MANUAL

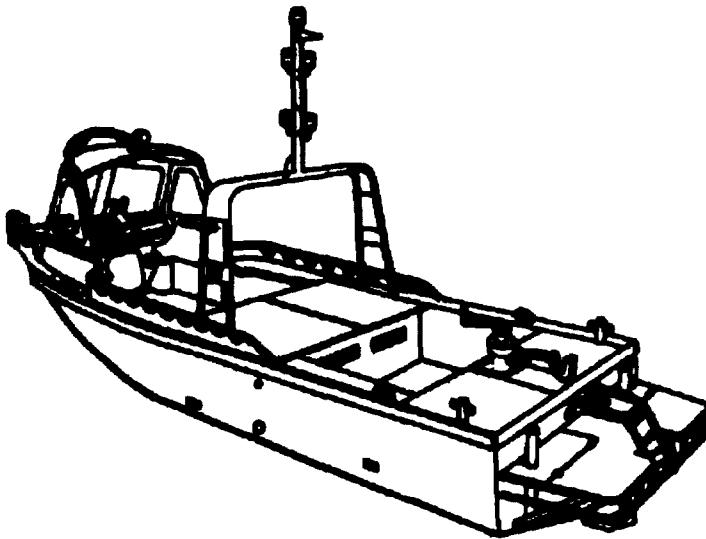

INTRODUCTION
PAGE 1-1

END ITEM MAINTENANCE INSTRUCTIONS
PAGE 2-1

COMPONENT MAINTENANCE INSTRUCTIONS
PAGE 3-1

REFERENCES
PAGE A-1

MAINTENANCE ALLOCATION CHART
PAGE B-1

EXPENDABLE SUPPLIES AND
MATERIALS LIST
PAGE C-1

ILLUSTRATED LIST OF MANUFACTURED
ITEMS
PAGE D-1

BOAT, BRIDGE ERECTION,
TWIN JET, ALUMINUM HULL
MODEL USCSBMK1 (1940-01-105-5728)
MODEL USCSBMK2 (1940-01-218-9165)

DISTRIBUTION STATEMENT A: Approved for public release; distribution is unlimited.

***This manual supersedes TM 5-1940-227-20, dated 16 November 1981.**

HEADQUARTERS, DEPARTMENTS OF THE ARMY
AND HEADQUARTERS, U.S. MARINE CORPS
29 APRIL 1994

CHANGE
NO. 1

HEADQUARTERS, DEPARTMENT OF THE ARMY
AND HEADQUARTERS, U.S. MARINE CORPS
WASHINGTON, D.C., 6 December 1996

UNIT MAINTENANCE MANUAL

**BOAT, BRIDGE ERECTION,
TWIN JET, ALUMINUM HULL,
MODEL USCSBMK1 (1940-01-105-5728)
MODEL USCSBMK2 (1940-01-218-9165)**

DISTRIBUTION STATEMENT A: Approved for public release; distribution is unlimited

TM 5-1940-277-20/TM 1940-20/2,29 April 1994, is changed as follows:

1. Remove and insert pages as indicated below. New or changed text material is indicated by a vertical bar in the margin. An illustration change is indicated by a miniature pointing hand.

Remove pages
i/(ii blank)

3-281 through 3-284

Insert pages
i/(ii blank)

3-281 through 3-284

2. Retain this sheet in front of manual for reference purposes.

TM 5-1940-277-20
TM 1940-20/2
C1

By Order of the Secretaries of the Army and Navy (including the Marine Corps):

DENNIS J. REIMER
General, United States Army
Chief of Staff

Official:

JOEL B. HUDSON

Administrative Assistant to the
Secretary of the Army
02986

J. E. BUFFINGTON
Rear Admiral, CEC, US Navy
Commander
Navy Facilities Engineering
Command

M. K. HAYDEN
Colonel, USMC
Director, Program Support
Marine Corps systems command

DISTRIBUTION:

To be distributed in accordance with DA Form 12-25E, block no. 0263, requirements for
TM 5-1940-277-20.

**WARNING****SERIOUS INJURY OR DEATH**

may result if personnel fail to observe the following safety precautions.

Batteries give off explosive hydrogen gas. Be careful while making connections. Do not smoke when servicing the battery.

Be sure the master battery switch is off before disconnecting or connecting battery cables.

Always disconnect the ground cable first and connect it last. Make sure the POS (+) and NEG (-) connections are correct.

Do not ground the positive terminal of batteries to boat structure.

Do not operate engines in an enclosed area without adequate ventilation as carbon monoxide, an invisible poisonous gas, is generated. Symptoms of exposure to carbon monoxide are headache, dizziness, drowsiness, loss of muscular control and coma. Severe exposure can cause permanent brain damage.

Wear life preservers (type 1) at all times when aboard the boat.

Do not allow personnel between boats during slave starting.

Maintenance procedures for the fuel system must be performed in a well-ventilated area. Do not allow sparks or flame in the vicinity.

Before performing any repair on the electrical system, place master switch OFF and disconnect negative battery cables.

For Artificial Respiration, refer to FM 21-11.

Ear protection (ear plugs) must be worn when operating this boat.

When working near mast assembly, avoid striking head on protruding parts of mast assembly. To avoid injury, be aware of mast assembly position when working below mast.

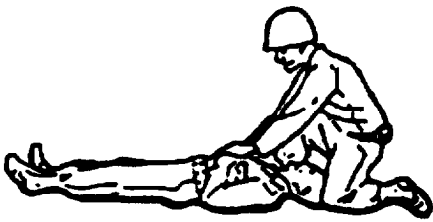

(a) HAND ON LOWER RIBS

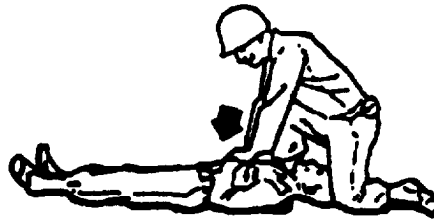

(b) STEADY PRESSURE DOWNWARD

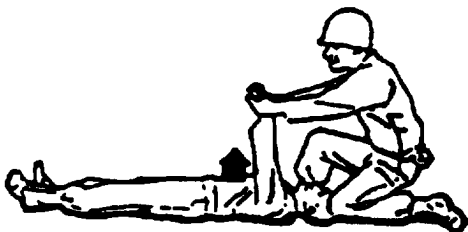

(c) ARMS LIFTED UPWARD

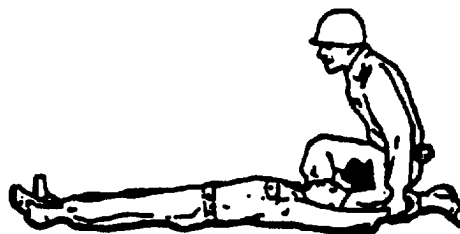

(d) ARMS BACKWARD AS FAR AS POSSIBLE

MOUTH-TO-MOUTH RESUSCITATION



NOSE SEALED WITH THUMB AND FINGER



OBSERVE RISE AND FALL
OF SOLDIER'S CHEST

HAND BEHIND HEAD

Figures from FM 21-11

TECHNICAL MANUAL
No. 5-1940-277-20

HEADQUARTERS, DEPARTMENT OF THE ARMY
AND HEADQUARTERS U.S. MARINE CORPS
WASHINGTON D.C., 29 APRIL 1994

UNIT MAINTENANCE MANUAL

BOAT, BRIDGE ERECTION, TWIN JET, ALUMINUM HULL
MODEL USCSBMK1 (1940-01-105-5728)
MODEL USCSBMK2 (1940-01-218-9165)

REPORTING ERRORS AND RECOMMENDING IMPROVEMENTS

You can help improve this manual. If you find any mistakes, or if you know of a way to improve these procedures, please let us know. Mail your letter or DA Form 2028 (Recommended Changes to Publications and Blank Forms), or DA Form 2028-2 located in the back of this manual directly to: Commander, US Army Aviation and Troop Command, ATTN: AMSAT-I-MP, 4300 Goodfellow Blvd., St. Louis, MO 63120-1798. You may also submit your recommended changes by E-mail directly to <mpmt%avma28@st-louis-emh7.army.mil>. A reply will be furnished directly to you. Instructions for sending an electronic 2028 may be found at the back of this manual immediately preceding the hard copy 2028.

Marine Corps users submit NAVMC 10772 Form to Commanding General, Marine Corps Logistics Base (Code 850) Albany, GA 31704-5000.

DISTRIBUTION STATEMENT A: Approved for public release; distribution is unlimited.

	PAGE
CHAPTER 1 INTRODUCTION	1-1
Section I General Information	1-1
Section II Equipment description	1-1
Section III Technical Principles of Operation	1-14
CHAPTER 2 END ITEM MAINTENANCE INSTRUCTIONS	1-1
Section I Repair Parts; Special Tools; Test, Measurement, and Diagnostic Equipment (TMDE); and Support Equipment	2-1
Section II Service Upon Receipt	2-1
Section III Preventive Maintenance Checks and Services (PMCS)	2-1
Section IV Troubleshooting	2-17
Section V Maintenance procedures	2-34
CHAPTER 3 COMPONENT MAINTENANCE INSTRUCTIONS	3-1
APPENDIX A REFERENCES	A-1
APPENDIX B MAINTENANCE ALLOCATION CHART	B-1
APPENDIX C EXPENDABLE SUPPLIES AND MATERIAL LISTS	C-1
APPENDIX D ILLUSTRATED LIST OF MANUFACTURED ITEMS	D-1
GLOSSARY	Glossary-1
ALPHABETICAL INDEX	Index 1
MK1 AND MK2 WIRING DIAGRAM	FO-1
FUEL SYSTEM DIAGRAM	FO-2
COOLING SYSTEM DIAGRAM	FO-3

This manual supersedes TM 5-1940-277-20, dated 16 November 1981.

CHAPTER 1

INTRODUCTION

Section I. GENERAL INFORMATION

1-1 SCOPE.

- a. Type of Manual: Unit Maintenance Manual.
- b. Equipment Name and Model Number: Bridge Erection Boat, Twin Jet, Aluminum Hull. The model numbers assigned to this equipment are USCSBMK1 and USCSBMK2.
- c. Purpose of Equipment: Support bridging and amphibious operations. May also be used as a general purpose workboat in support of diving operations and maritime projects, for inland water patrols, and as a safety boat for amphibious river crossings.
- d. Special Limitations on Equipment: When used to ferry troops or cargo, the safe carrying capacity is limited to a maximum of 12 fully equipped men or 4400 pounds (2000 kilograms).

1-2. MAINTENANCE FORMS AND RECORDS. Department of the Army forms and procedures used for equipment maintenance will be those prescribed by DA Pam 738-750, The Army Maintenance Management System (TAMMS). Marine Corps personnel will prepare and maintain records and report forms as prescribed by TM 4700-15/1, Equipment Record Procedures.

1-3. REPORTING EQUIPMENT IMPROVEMENT RECOMMENDATIONS. If your boat needs improvement, let us know. Send us an Equipment Improvement Recommendation (EIR). You, the user, are the only one who can tell us what you don't like about your equipment. Let us know why you don't like the design or performance. Put it on an SF 368 (Quality Deficiency Report). Mail it to us at Commander, U.S. Army Aviation and Troop Command, ATTN: AMSAT-I-MDO, 4300 Goodfellow Boulevard, St. Louis, MO 63120-1798. U.S. Marine Corps users are encouraged to submit EIRs in accordance with MCO 1650.17, or submit Quality Deficiency Reports in accordance with MCO 4855.10. Mail it to us at Commanding General (P840), Marine Corps Logistics Base, Albany, GA 31704-5000. We'll send you a reply.

1-4. WARRANTY INFORMATION. The Bridge Erection Boat, USCSBMK1, is warranted by Fairey Allday Marine Limited for 12 months. The Bridge Erection Boat USCSBMK2 is warranted by American Development Corporation for 12 months. The warranty starts on the date found in block 23 of DA Form 2408-9 in the logbook. Report all defects in material or workmanship to your supervisor, who will take appropriate action through your unit maintenance supervisor.

1-5. GLOSSARY.

Berth	Place at dock where boat is tied up or anchored.
Capstan	Manually rotated vertical cylinder for winding rope or cable.
Hydrojet	Propelling system that uses water.
MK1 (USCSBMK1)	Combat Support Boat, Mark 1. Original model of Bridge Erection Boat.
MK2 (USCSBMK2)	Combat Support Boat, Mark 2. Modified model of Bridge Erection Boat.
Raw water	River water.
Rub rail	Rubber bumper strip around boat hull.
Scoop	Movable metal cover that directs water stream that comes from jets.
Thermostarter	Glow plug used to preheat intake air for cold starting.
Vdc	Volts direct current.

Section II. EQUIPMENT DESCRIPTION

1-6. PURPOSE OF BRIDGE ERECTION BOAT. A transportable, hydrojet propelled, aluminum hull boat designed to maneuver components of floating bridges. The boat can also be used to propel rafts, support diving operations, assist in maritime construction projects, serve as a troop and cargo carrier, and patrol inland waters.

1-7. CAPABILITIES AND FEATURES.

- a. Can rotate on its own axis at low engine speeds.
- b. All weather operational.

- c. Transportable by rail, road, and air. (See Technical Bulletin TB 55-46-1.)
- d. Positive flotation.

MK 1

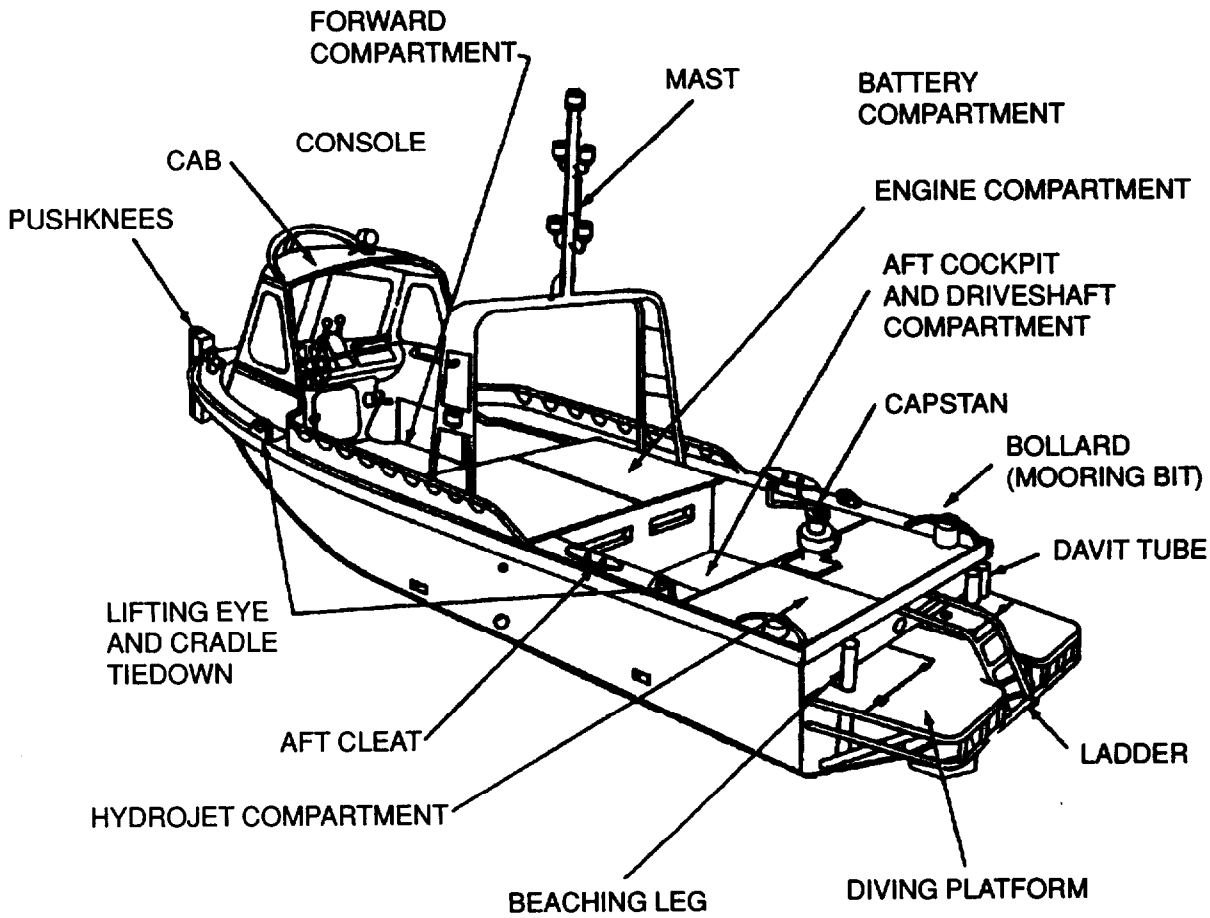

MK 2

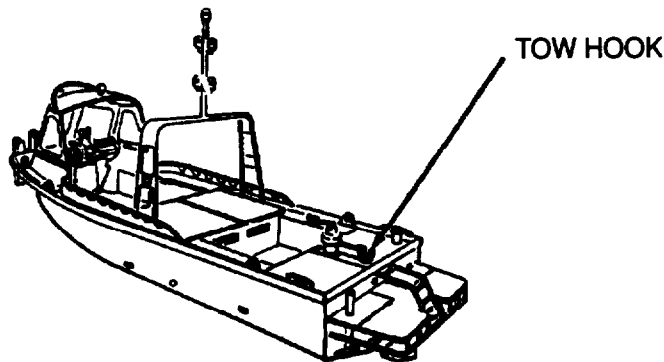

1-8. LOCATION AND DESCRIPTION OF MAJOR COMPONENTS.

- a. Removable Cab (1). An aluminum frame with windows and aluminum roof that can be attached to the boat to provide protection for the crew during bad weather: The cab is provided with windshield wiper and a place for attaching searchlight.
- b. Control Console (2). Contains all the controls and indicators required for operation of the boat. In addition, it contains a hand operated bilge pump, a stowage compartment for technical manuals, and a stowage compartment for life preservers and other gear.

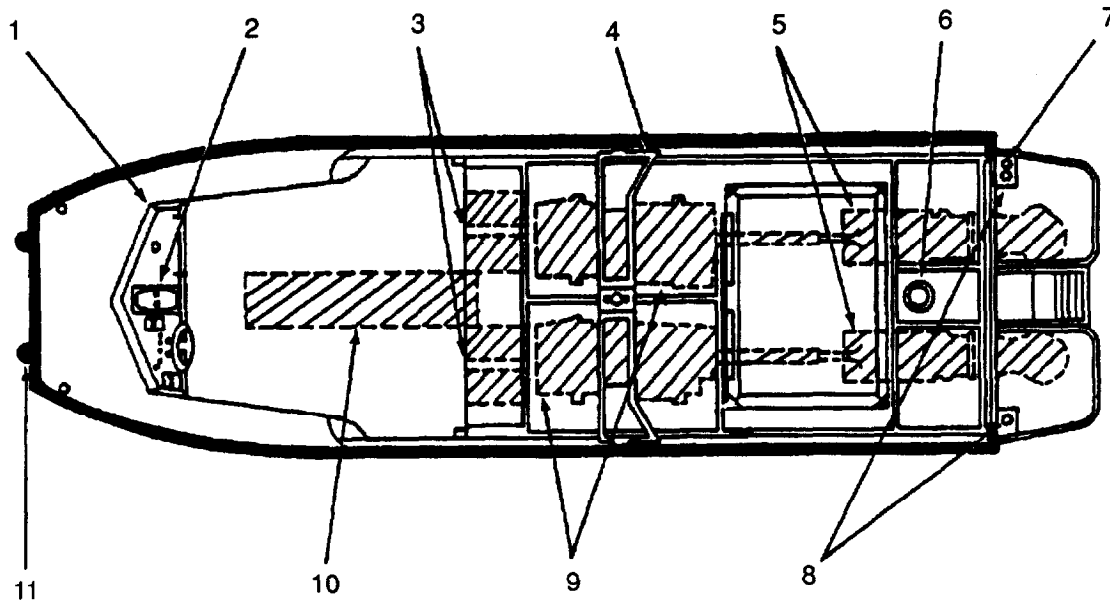

- c. Batteries (3). Provide electrical power for the operation of the boat.
- d. Removable Mast (4). Contains the navigation lights, towing lights, and anchor lights. May be lowered to rest on capstan or removed from the boat when lights are not required.
- e. Hydrojets (5). Consist of diesel engine driven hydrojet propulsion units with directional nozzles and scoops. The propulsion units propel the boat and steer it.
- f. Capstan (6). A two-speed hand-operated winching device used for towing, winching, and other work tasks.
- g. Davit Tube (7) (MK1 only). Allows the attachment of a davit (small crane) to the boat for use in diving operations. Not used in U.S. Army operations.
- h. Beaching Legs (8). Support the boat in an upright position when on a hard surface and not in cradle. The beaching legs are retractable.
- i. Engines (9). Provide power for driving hydrojet units.
- j. Fuel Tank (10). Provides fuel storage capacity for operation of boat.
- k. Pushknees (11). Provides the front of the boat with a flat vertical surface for pushing barges or maneuvering bridge components. The pushknees can be removed.

CAUTION

Do not beach boat on rock shores. Damage to keel and keel cooler may result.

- l. Keel Coolers (12) (MK2 only). Provide cooling for the engine, transmission, oil, and turbocharged air. Located on the bottom of the boat.

- m. Tow Hook (13). Provides towing capability for pulling disabled boats. The two hook has a quick-release mechanism for disengaging a dangerous load.

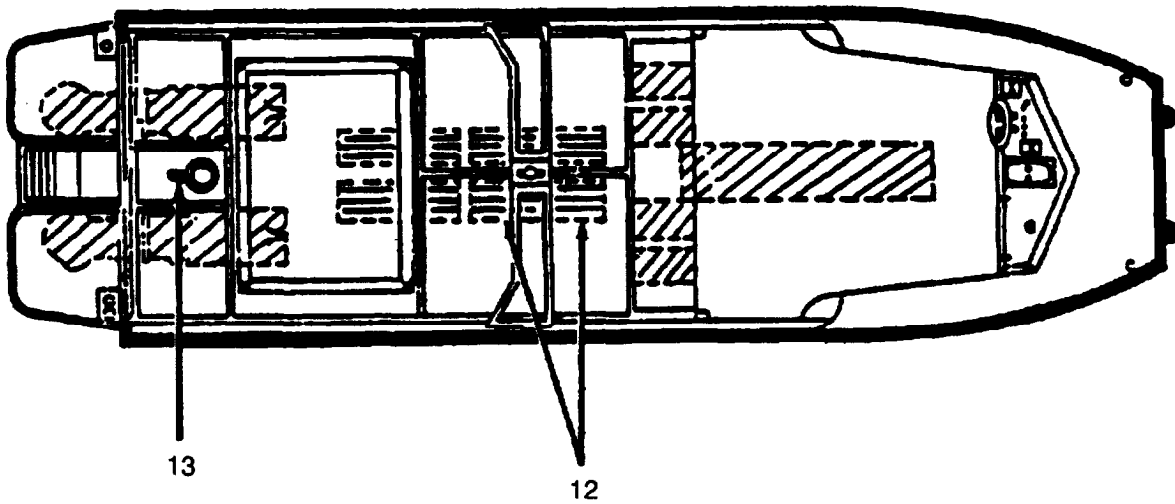

1-9. LOCATION AND DESCRIPTION OF FORWARD COCKPIT AND CONTROL CONSOLE. The console is located at the forward end of the boat and contains the controls necessary to operate the boat, the manual bilge pump, and stowage compartments.

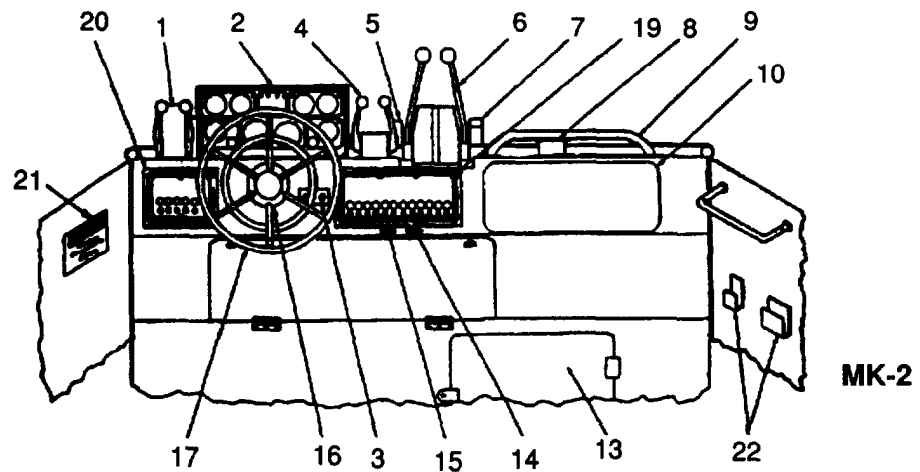
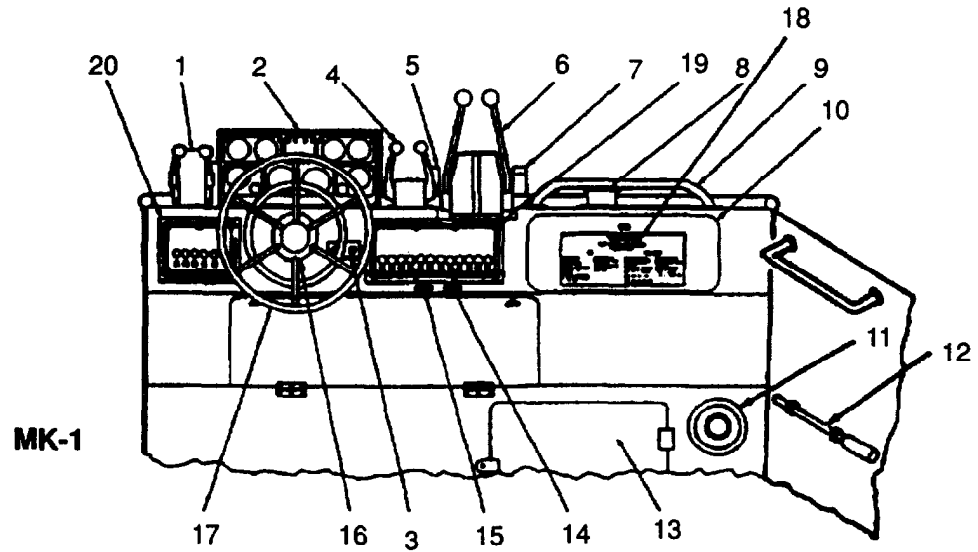

- a. Transmission Selector Lever (1). Allows operator to place individual gears in forward-neutral-reverse position.
- b. Engine Instrument Panel (2). Contains oil pressure gages, engine water temperature gages, engine tachometers, battery condition meter, ignition switches, and warning lights.
- c. Engine Alarm Mute Switch (3). Allows operator to turn off engine audible alarm. (Indicates low engine oil pressure or high water temperature.)
- d. Engine Throttle Controls (4). Allows operator to control the revolutions per minute (rpm) of each engine.
- e. Cab Electrical Connector (5). Provides electrical connection for cab windshield wipers and searchlight.
- f. Scoop Control (6). Allows operator to control direction of output from hydrojets to obtain forward and reverse direction of boat. May also be used to assist in turning boat and controlling speed.
- g. Searchlight Socket (7). Provides electrical connection for searchlight when cab is removed.
- h. Searchlight Mounting (8). Provides mounting for searchlight when cab is removed.
- i. Handrail (9). Provides a safety rail.
- j. Map Locker (10). Provides stowage space for technical manuals.
- k. Bilge Pump, Hand Operated (11). Provides manual means of pumping water from bilge (MK1).
- l. Pump Handle (12). Removable handle for hand operated bilge pump (MK1) stowed on starboard bulkhead under the console.
- m. Storage Locker (13). Provides a lockable stowage compartment for life jackets and other equipment.
- n. Engine Stop Control, Starboard (14). Stops the starboard engine when pulled out.
- o. Engine Stop Control, Port (15). Stops the port engine when pulled out.
- p. Scoop Position Indicator (16). Provides a means for the operator to position the scoops for straight ahead movement of the boat. (Located on steering column directly behind steering wheel.)
- q. Steering Wheel (17). Used to steer the boat.
- r. Warning Decal (18). Indicates to the operator that caution should be taken (MK1).
- s. Switch Panel Unit 1 (19). 12-circuit power panel contains electrical switches for cabin lights, inspection light, mast light, wipers (port and starboard), emergency battery link, and searchlight.
- t. Switch Panel Unit 2 (20). 6-circuit power panel contains electrical switches for forward and aft bilge pumps, auto control of bilge pumps and horn. Engine room blower is not used.
- u. Caution Plate (21). Indicates to operator that hearing protection is required for noise pollution (MK2 only).
- v. Hatchet Bracket (22). To secure hatchet for emergency use (MK2 only).

EQUIPMENT DATA

WEIGHTS AND DIMENSIONS

Operating	
Weight, w/crew, equipment and fuel (gross)	8800 lbs (4000 kg)
Length	322.8 in (820 cm)
Beam	98.0 in (249 cm)
Height	
w/o cab or mast	77.9 in (198 cm)
w/cab	109.8 in (279 cm)
w/cab and mast	177.9 in (452 cm)
Draft	
w/crew, equipment and fuel	22.0 in (56 cm)
fully loaded	26.0 in (66 cm)
Transported, w/cradle	
Weight	10800 lbs (4909 kg)
Length	326.4 in (826 cm)
Height w/o cab	96.3 in (244 cm)
Width	116.3 in (294 cm)
Shipping weight	11,100 lbs

PERFORMANCE

Speed, w/crew, equipment and fuel	21.6 mph (40 km/hr)
Speed, fully loaded	16.2 mph (30 km/hr)
Maximum load carrying capacity	4400 lbs (2000 kg)
Towing hook	400 lbs (2000 kg)
Turning radius (with scoops at maximum thrust)	
Full speed ahead	2 boat lengths in 15 seconds
Full speed astern	2 boat lengths in 25 seconds
One scoop forward and one scoop in reverse	Standing circle
Fuel consumption (approximate)	
1750 rpm	2.8 gallons/hour (11 liters/hour)
2000 rpm	4.2 gallons/hour (18 liters/hour)
2250 rpm	6.0 gallons/hour (23 liters/hour)
2450 rpm	10.8 gallons/hour (40 liters/hour)
Minimum forward thrust at 2450 rpm	4200 pounds (18.7 km)
Minimum reverse thrust at 2450 rpm	2200 pounds (9.8 km)
Maximum safe engine operating speed	
MK1	2800 rpm
MK2	2900 rpm

CAPACITY

Fuel	75 gallons (280 liters)
Oil	
Engine	17-1/2 quarts (18.4 liters)
Transmission	2-1/2 quarts (2.35 liters)
Coolant	
MK1	7-1/5 gallons (27 liters)
MK2	18 gallons (68.1 liters)

ENGINE INSTRUMENT PANEL GAGE READINGS

Tachometer	
Idle speed	650 to 750 rpm
Operating speed	1000 to 2000 rpm
Maximum speed (Under Load)	2500 rpm
Engine oil pressure gage	
Idle speed	20 to 30 lb/in ² (1.4 to 2.1 Kp/cm ²)
Operating speed	40 Lb/in ² or above (2.8 Kp/cm ²)
Coolant temperature gage (fresh water system)	
Normal	Below 195°F (90°C)
Overheating	Above 195°F (90°C)
Battery condition meter (engine not running, no electrical load)	
Battery fully charged	25.4 volts or above
Battery half charged	24.6 to 25.4 volts
Battery fully discharged	23.7 volts or below

NOTE

The above readings are most reliable if the batteries have stood for at least 8 hours with-out charge or discharge.

Battery condition meter (engine running about 1500 rpm and no electrical load)	
Battery near to fully charged	27.0 to 28.0 volts
Battery partially discharged	24.0 to 27.0 volts
Battery charge low	Below 24.0 volts
Battery condition meter (normal operation)	
Above 24 volts	Alternator output matching or greater than electrical load
Below 24 volts	Load in excess of alternator output
Opening temperature range for thermostat	160°F - 170°F

NOMENCLATURE

Boat, Bridge Erection,
Twin Jet, Aluminum Hull

HULL

Manufacturer	
MK1	Allday Aluminum Limited, Gosport Hampshire PO12 4DT England
MK2	American Development Corporation (ADCOR) 1930 Hanahan Road North Charleston, SC 29406
Length (overall)	322.8 inches (820 cm)
Width (overall)	98 inches (249 cm)

Height (with cab)	109.8 inches (279 cm)
Height (without cab)	77.9 inches (198 cm)
Weight	8800 lbs (4000 kg)
Construction	Welded aluminum
ENGINE	
Manufacturer	Sabre Engines Ltd. Ferndown Industrial Estate, Wimborne Dorset, England
Model	212
Maximum rpm (no load)	
MK1	2800 rpm
MK2	2900 rpm
Shaft horsepower	212 @ 2500 rpm (\pm 50 rpm)
Weight (dry)	1358 lbs (with transmission) (616 kg)
No. of cylinders	6
Bore	4.125 inches (105 mm)
Stroke	4.524 inches (115 mm)
Total displacement	363 cubic inches (5.95 liters)
Rotation	Counterclockwise (as viewed from fly-wheel)
Firing order	1, 5, 3, 6, 2, 4
Compression ratio	14.7 to 1
Compression pressure (min.)	300 psig
Valve clearance (hot)	0.018 inch
No. of main bearings	7
Upper main bearings	Grooved, oil feed holes, steel backed aluminum tin liners
Lower main bearings	Groove in center and rear lin- ers only, steel backed alu- minum tin liners
Oil pump	Sliding vane type camshaft
Idle speed	650 to 750 rpm
Fresh water capacity	
MK1	7-1/5 gallons (27 liters)
MK2	18 gallons (68.1 liters)
Lubricating oil capacity	17-1/2 quarts (16.8 liters)
Injection pump timing	21° BTDC
Diesel fuel specification	W-F-800
Lubrication specification	MIL-M-2104

FUEL INJECTOR

Manufacturer

CAV Limited,
P.O. Box 36
Warple Way,
London, England

Model

49053

Nozzle setting pressure

2999 psig (205 atms)

ALTERNATOR

Manufacturer

CAV Limited,
P.O. Box 36
Warple Way,
London, England

Model

AC5

Type

Three-phase, stationary field,
revolving armature, self-
limiting in current output:
17A at 2200 rpm,
22A at 3000 rpm

STARTER MOTOR

Manufacturer

CAV Limited,
P.O. Box 36
Warple Way,
London, England

Model

CA45

HYDRAULIC MARINE GEAR (TRANSMISSION)

Manufacturer

Warner Gear Division
Borg Warner Corp.
Muncie, Indiana
47302

Model

10-18-002

Type

Hydraulically clutched for-
ward-reverse transmission

Rotation

Counterclockwise

Forward-reverse selection

Hydraulic fluid direction to
clutches by selector valve
inside transmission

Front oil pump

Positive displacement, gear
type (driven at engine
speed)

Oil type

Engine oil

Oil pressure (normal)

110.0 to 150.0 pounds per
square inch (7.7 to 10.5
Kp/cm²)

Oil pressure (maximum)

250.0 pounds per square inch
(17.5 Kp/cm²)

Oil temperature (normal)

155° to 165° Fahrenheit
(68.3 to 73.8°C)

Regulator valve spring weight

98 to 108 pounds at 1-1/16
inch height (44.5 to 49.1
Kg at 2.7 cm)

STEERING PROPULSION SYSTEM

Manufacturer

Downty Hydraulic Units Limited
Cheltenham, England

Type

Hydrojet, 12 inch (300 mm diameter, two stage with scoops for reversing water flow and nozzles that swing through an angle of 40 degrees either side of central position for steering

Steering

Through cable control from helm in front cockpit to steering assembly portion of the hydrojet unit

ELECTRICAL SYSTEM (24 Volts Direct Current)

Batteries

Voltage

12

Number

4

Connection

Two batteries are connected in series to give 24-volt output; one pair is used to provide starting power and the second pair to provide all light and bilge pump operation power

ACCESSORIES

Electric bilge pumps

Manufacturer

EMPO Pump Co., Inc.
Piqua, Ohio

Model

32-30

Type

Heavy-duty enclosed motor-driven impeller

Discharge venting

Forward pump discharges through vent in transom onto driver's platform

Manual bilge pump

Manufacturer (MK1 only)

Henderson Pumps and Equipment Ltd.
38 Medina Road,
Cowes, Isle of Wight, PO 31,7BZ,
England

Model

MkV

Type

Hand-operated diaphragm pump

1-10. DIFFERENCES BETWEEN MODELS. There are two models of the Bridge Erection Beat, the MK1 and the MK2. The two models have different engine cooling systems.

- a. The MK1 uses two closed fresh water systems. Raw water is also drawn from the hydrojet unit to pass through a remote exchanger unit which cools the fresh water flowing through the remote unit's coil. The exhaust system expels exhaust gases and raw water via port and starboard wet exhaust outlets.

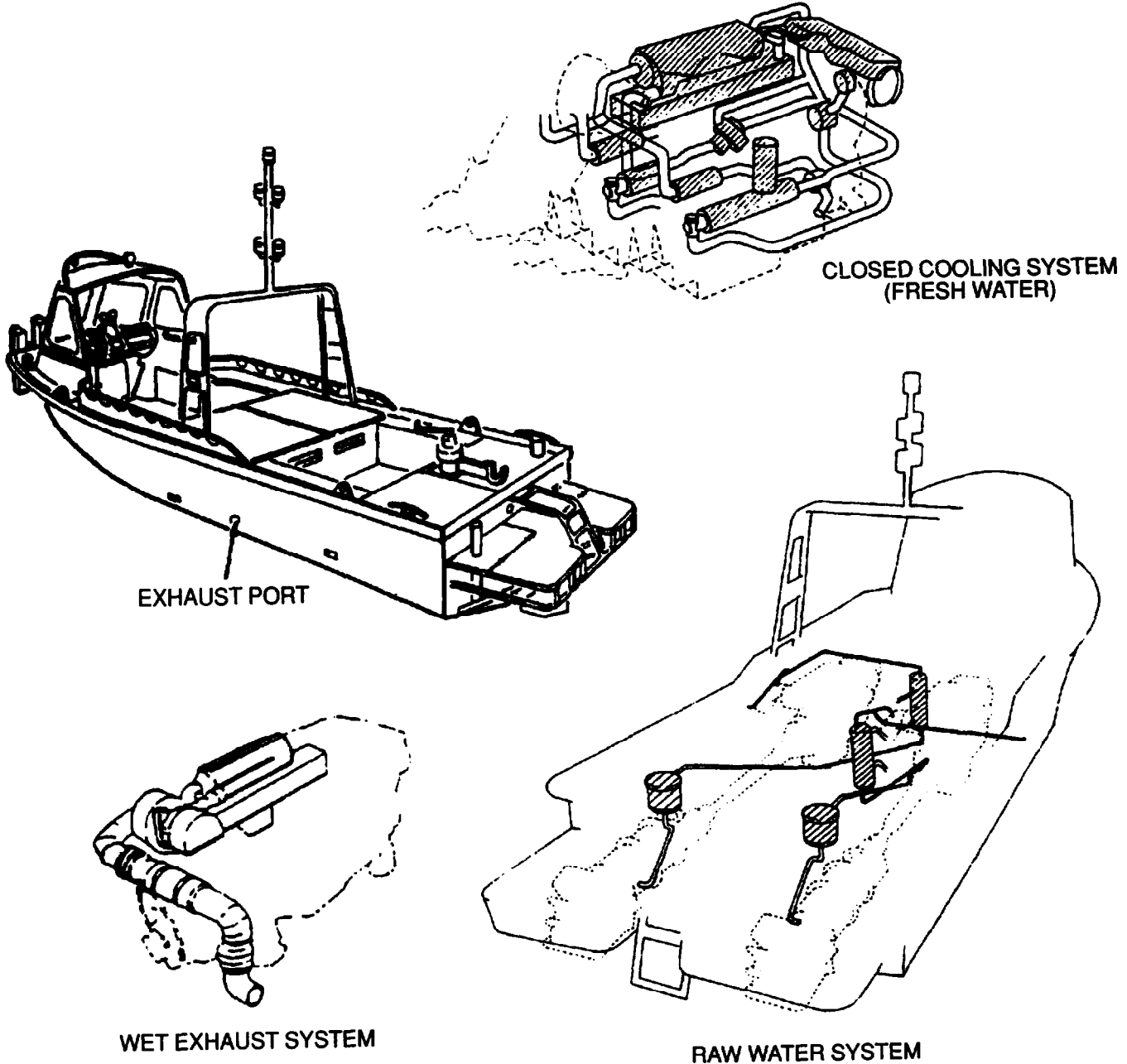

- b. MK2. Each MK2 engine uses two closed cooling systems which share a common reservoir. The MK2 uses a wet exhaust system similar to the MK1. The hydrojet forces raw water into the exhaust system and out the exhaust port on the side of the boat.

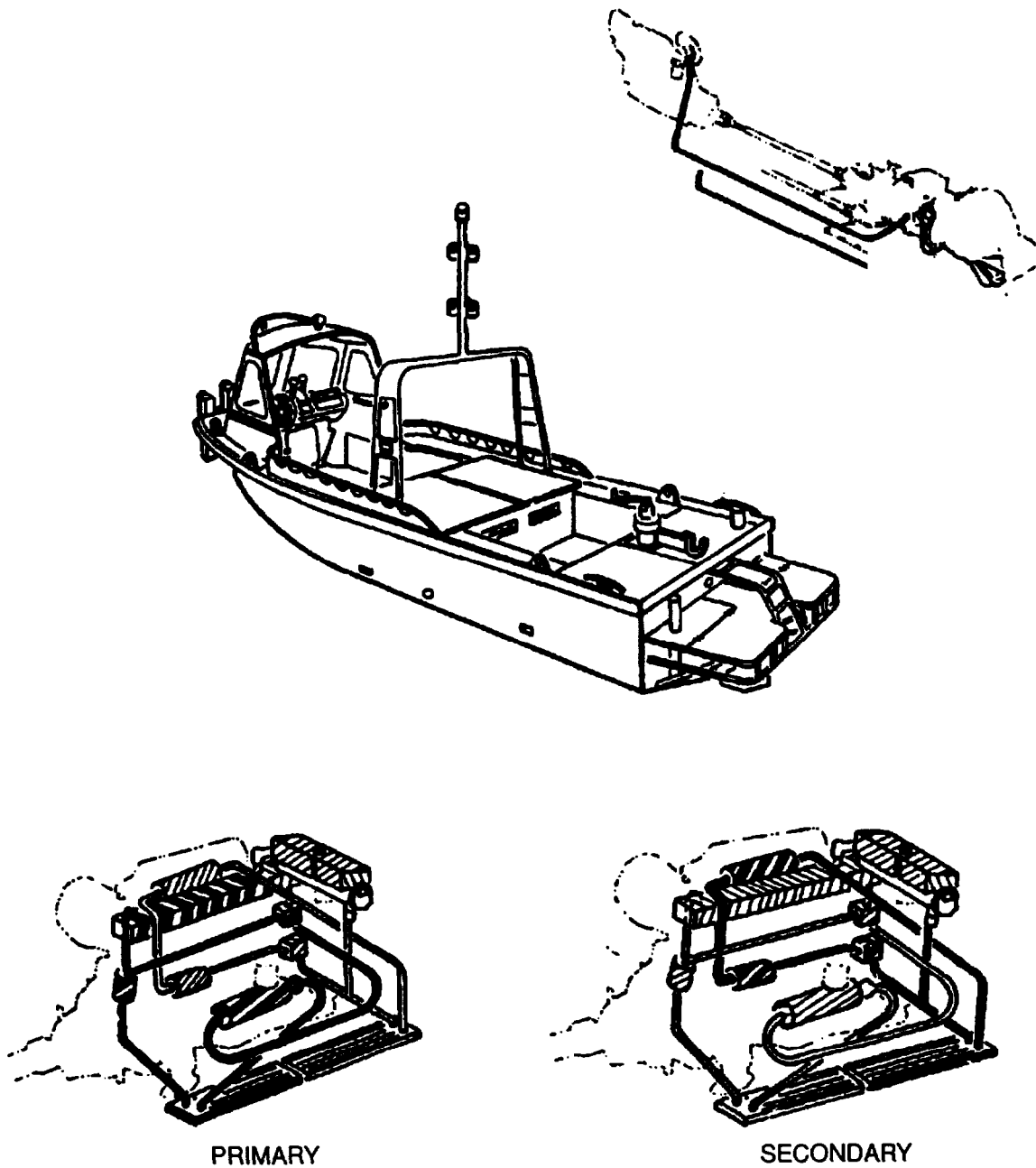

CLOSED COOLING SYSTEMS
(FRESH WATER)

Section III. TECHNICAL PRINCIPLES OF OPERATION

1-11. PROPULSION SYSTEM.

- a Engines - are 363 cubic inches (5.95 liter), 212 horsepower, 6-cylinder, water-cooled, diesel engines. Engine speed is adjusted by the throttle control mounted on the control console. Fuel is provided by an external fuel system. Cooling systems are explained in paragraphs 1-12 and 1-13.
- b. Transmissions - are 3-position, direct drive, hydraulically operated, oil-cooled units that transmit power from each engine to its respective drive shaft.

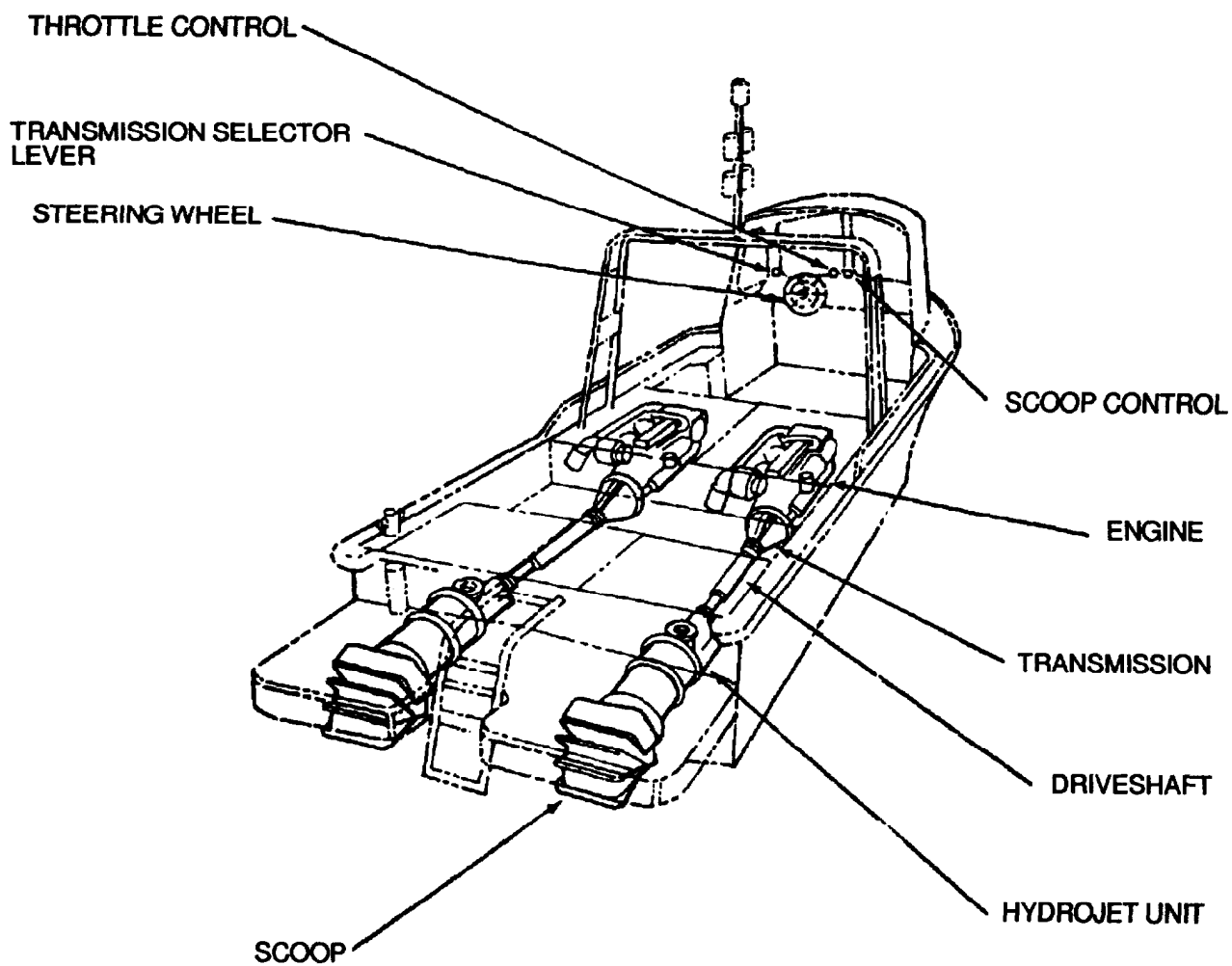

- c. Drive-Neutral-Reverse - position of each transmission is separately and mechanically adjusted by the transmission selector lever located on the control panel.
- d. Drive Shafts - transfer power from engines to hydrojet units.
- e. Hydrojet Units - are hydrojet propulsion units that provide the thrust to move and steer the boat. Water is drawn in through grilles in the underside of the boat and expelled through nozzles mounted beyond the back of the boat. The force with which the water is expelled depends on the speed of the engine.
- f. Scoops - are movable metal shields that fit over the nozzles of the propulsion units and direct the flow of water from the nozzle. The position of the scoops is mechanically adjusted by the steering wheel and the scoop control levers mounted on the control panel. The steering wheel controls the port-starboard directional movement of the boat. The scoop control levers control the forward-reverse motion of the boat. At low speeds, the scoop control can be used to turn the boat by having one scoop in reverse position and the other in neutral or forward position.

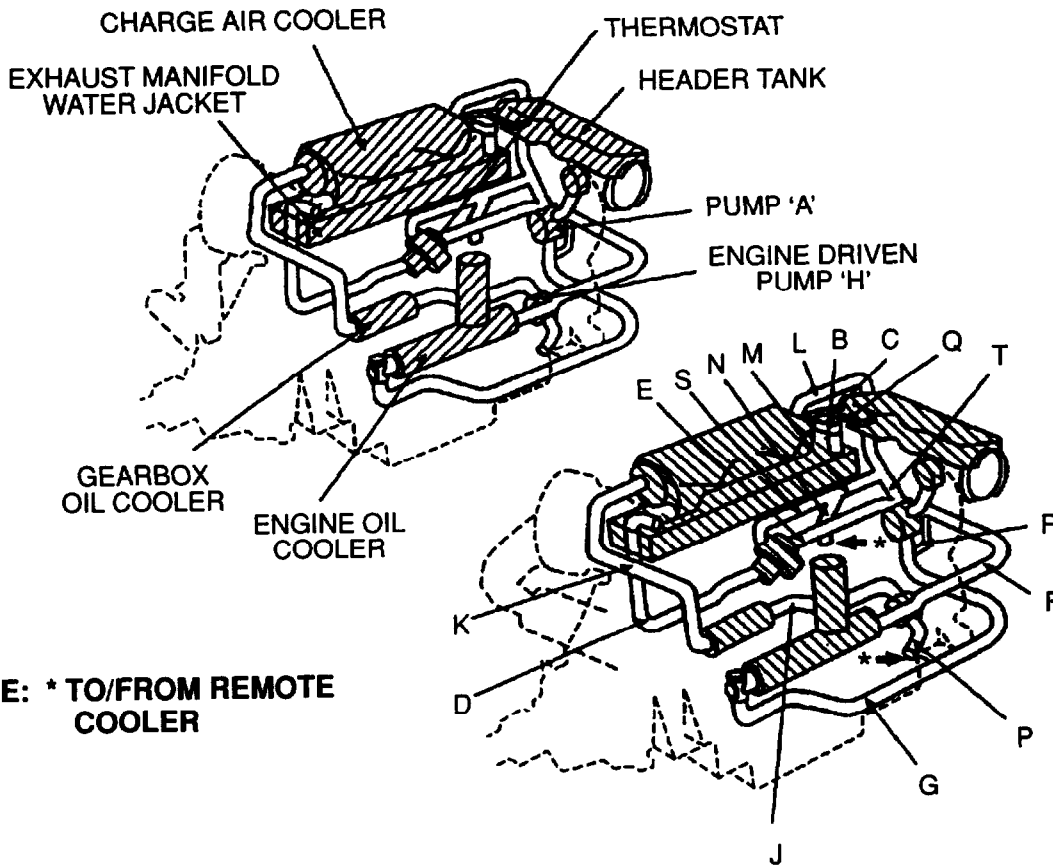
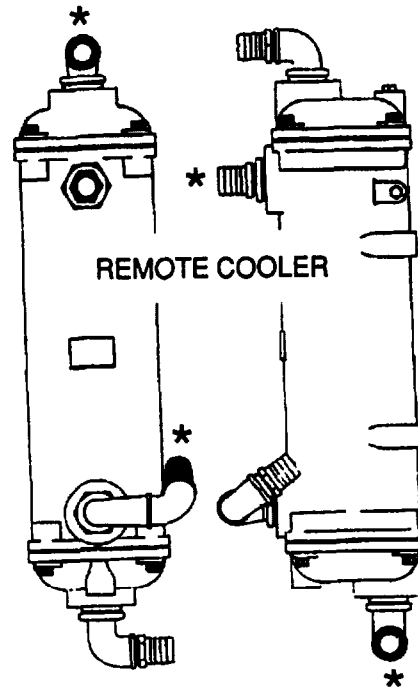
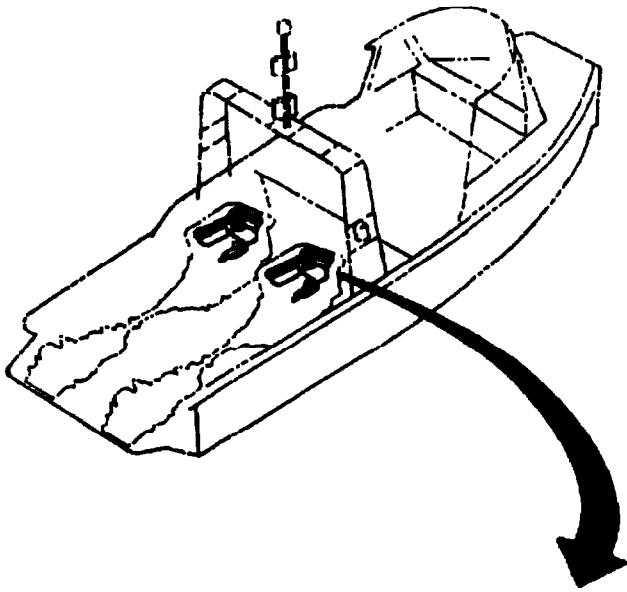

NOTE: * TO/FROM REMOTE COOLER

MK 1 FRESH WATER ENGINE COOLING SYSTEM

1-12. MK1 ENGINE COOLING SYSTEM.

The coolant circuits and components are shown on preceding page.

a. Flow During Engine Warm Up

During this type of operation the system is divided into two principal circuits (1) and (2), which are almost independent of each other with a third circuit (3) providing de-aeration.

(1) Thermostatically Controlled Cylinder Block Circuit

In this circuit, water is circulated by the conventional engine mounted water pump 'A', which directs water into the block and then the cylinder head. From there, the water is taken by duct 'B' to the water jacket around the exhaust manifold. A small pipe 'C' connects to the header tank to allow air to escape during filling, also providing a small flow when the engine is running so that continuous de-aeration takes place. From the exhaust manifold jacket, the water flows through pipe 'D' to the full flow bypass thermostat. If the water temperature is below the thermostat opening temperature, the flow passes through pipes 'E' and 'F' to the engine oil cooler, and then through pipe 'G' to the pump 'A', thus completing the circuit.

(2) Low Temperature Circuit

A pump 'H' directs water through pipe 'J' to the gearbox oil cooler, and then through pipe 'K' to the charge air cooler. The water then flows through pipes 'C', 'M', and 'N' to the 'remote cooler'. From the 'remote cooler' the water returns to the pump 'H' via pipe 'P'. A small pipe 'Q' allows air to escape from the circuit when filling, and provides continuous de-aeration when the engine is running.

(3) Header Tank Circuit

The header tank receives a small flow of water through pipes 'Q' and 'C', and returns make-up water through pipe 'R', close to the inlet to pump 'A'.

b. Flow When Engine Coolant Is Up To Normal Operating Temperature

In this condition the flows described in a(1), a(2) and a(3) above continue, but an additional flow circuit is set up which connects the two circuits (1) and (2) together:

(1) Low Temperature Flow Diluting Thermostatically Controlled Cylinder Block Circuit

When the engine thermostat valve opens, water flows through pipe 'S' and then into pipe 'N' leading to the remote cooler. The water lost from the engine cylinder block circuit is replaced by water from the low temperature circuit, passing through pipe 'T' and diluting the 'by-pass' water flowing from 'E' and 'F'. By these means the temperature in the cylinder block circuit is controlled by the thermostat.

1-13. MK2 ENGINE COOLING SYSTEM.

a. Primary Engine Cooling System. The primary engine cooling system is identical for both port and starboard engines. Coolant flows from the primary water pump through the engine block to the header and through the exhaust manifold to the thermostat where it is diverted to the keel cooler or to the primary water pump. The coolant diverted to the keel cooler flows through the keel cooler to the oil cooler and back to the primary water pump.

- (1) Primary Water Pump - circulates the coolant through the primary cooling system.
- (2) Header (Expansion Tank) -acts as a reservoir for both primary and secondary engine cooling systems. The cap is fitted with a relief valve to prevent damage to the system by overpressurization.
- (3) Exhaust Manifold - serves as a heat exchanger where coolant flowing through the exhaust manifold cools the exhaust gases from the engine.
- (4) Thermostat - operates as a heat sensitive valve, diverting coolant either to the keel cooler or to the primary water pump.
- (5) Keel Cooler - serves as a heat exchanger where coolant from the primary cooling system is circulated through the rear keel cooler and is cooled by the raw water under the hull.
- (6) Oil Cooler - serves as a heat exchanger where oil from the engine is circulated through the oil cooler and is cooled by the coolant.

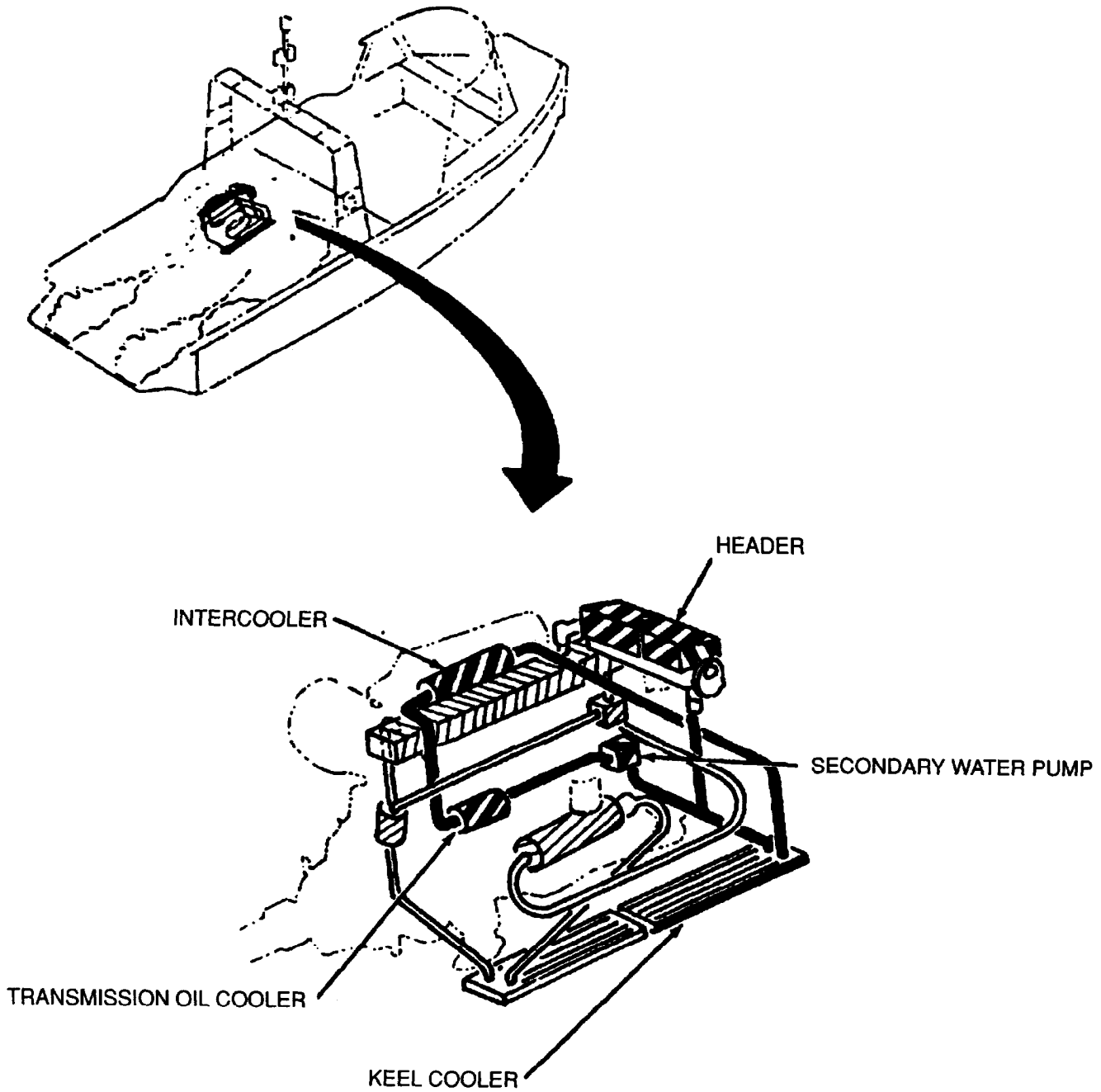

MK2 SECONDARY ENGINE COOLING SYSTEM

- b. Secondary Engine Cooling System. The port and starboard engines have their own separate secondary engine cooling systems. Coolant flows from the secondary water pump to the transmission oil cooler to the intercooler, and from the intercooler to the keel cooler. The coolant flows from the keel cooler back to the secondary water pump, picking up coolant as needed from the heater.
- (1) Secondary Water Pump - circulates the coolant through the secondary engine cooling system.
 - (2) Transmission Oil Cooler - serves as a heat exchanger where fluid from the transmission is circulated through the transmission cooler and is cooled by coolant.
 - (3) Intercooler - serves as a heat exchanger where coolant is used to cool engine intake air that has been heated by compression in the turbocharger.
 - (4) Keel Cooler - serves as a heat exchanger where coolant from the secondary engine cooling system is circulated through the front keel cooler and is cooled by the raw water under the hull.
 - (5) Header (Expansion Tank) - acts as a reservoir for both primary and secondary engine cooling systems. The cap is fitted with a relief valve to prevent damage to the system by overpressurization.

1-14. FUEL SYSTEM. Each engine has its own fuel system except that fuel is drawn from a common tank. The fuel systems are identical. The fuel flows from the tank through fuel water separators to the fuel lift pump mounted on the engine. The fuel is pumped through a fuel filter to the fuel injection pump and then to the injectors. From the fuel filter fuel also goes through a filter/reservoir to the thermostarter. Excess fuel from the fuel filter is returned to the tank. Excess fuel from the fuel injectors and the filter/reservoir is returned to the fuel tank through a collector.

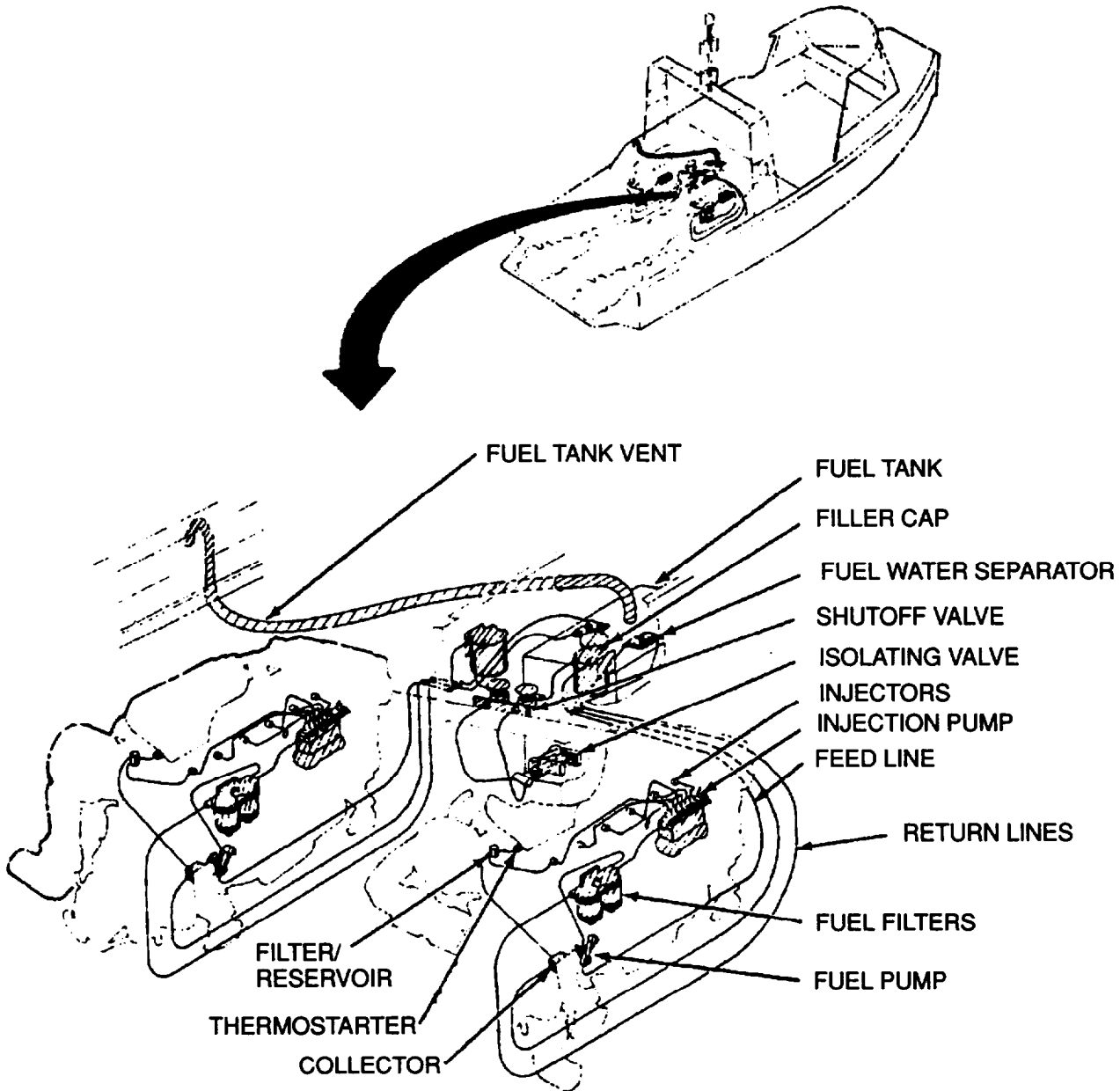

- a. Fuel Tank - is located on the centerline of the boat between the battery compartments and slightly forward of the engines. The tank is provided with a vent that vents fumes to the atmosphere and a filler cap for filling the tank. The filler cap has a dipstick for determining the exact amount of fuel in the tank. The tank is designed to prevent an explosion if the tank is penetrated by a bullet.
- b. Isolating Valve - is located at the bottom of the tank and is used to isolate the fuel tank from both engines.
- c. Shutoff Valve - is located near the top of the fuel tank and is used to isolate the engine from the fuel tank.
- d. Fuel Water Separator - is located near the top of the fuel tank and is used to remove water and coarse particles from the fuel.
- e. Fuel Tank Vent - is located next to the filler cap on the tank and extends over to the port side of the boat.
- f. Feed and Return Lines - are the nylon tubing that connect the engines to the fuel tank. The feed line supplies fuel to the engine. The return lines return excess fuel back to the tank.
- g. Fuel Lift Pump - is located on the right side of the engine near the rear mounting brackets. The fuel lift pump supplies fuel to the injection pump during start-up and operation.
- h. Fuel Filters - are the double bowl arrangement above the fuel lift pump. These filters remove particles from the fuel that could clog the injection pump or the injectors.
- i. Injectors - inject fuel into the engine cylinders.
- j. Filter/Reservoir - is located on the left side of the engine near the intercooler and has a small screened knob on top.
- k. Thermostarter - is located on the left side near the bottom of the air intake manifold. The thermostarter is used to heat the incoming air when the engine is started at temperatures below 50°F (10°C). The thermostarter operates by electrically igniting a small amount of fuel in the air intake manifold.
- l. Collector - is located near the fuel lift pump and is a collecting point for excess fuel from the filter/reservoir and leak-off from the injectors.
- m. Injector Pump - is located on the right side of the engine. It delivers an accurately measured quantity of diesel oil, under pressure, to the injector through which the fuel is injected into the engine cylinder.

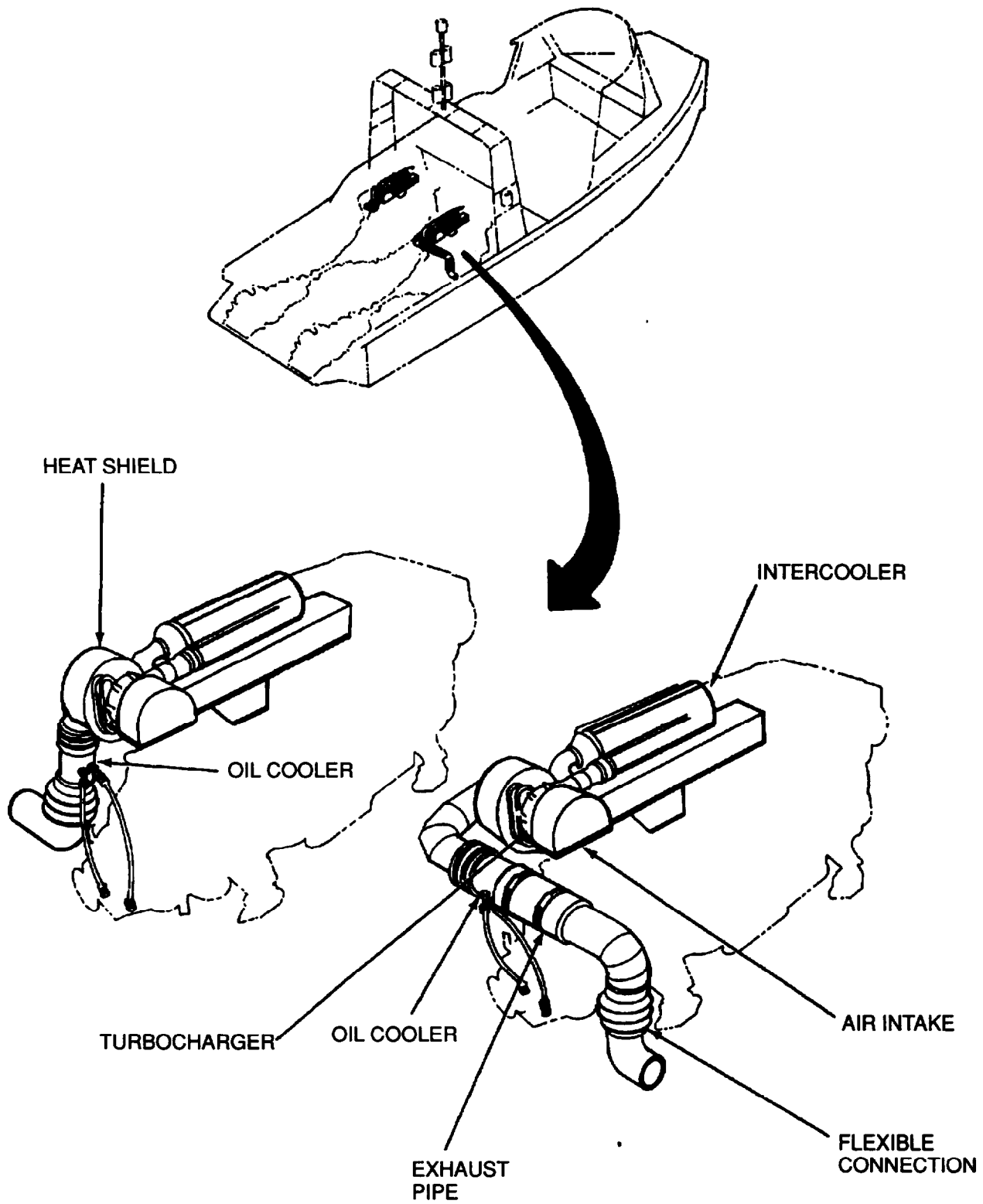

1-15. AIR-EXHAUST SYSTEM. The port engine and the starboard engine have individual air-exhaust systems. The systems are identical except that the port engine discharges exhaust gases to port and starboard engine discharges exhaust gases to starboard. Both port and starboard exhaust systems are cooled by raw water from the hydrojet. The MK2 exhaust is cooled by water from the hydrojet. On the MK1 boats, a hybrid system from self-contained fresh water cooling has been installed. Refer to paragraph 1-12 MK1 engine cooling system.

- a. Air Intake - draws air for combustion from the engine compartment. The air intake contains filters that remove particles from the air that could cause engine damage.
- b. Turbocharger - draws a large amount of air (approximately 360 cubic feet per minute) and supplies it to the intercooler where it is cooled before entering the intake manifold. The turbocharger is driven by exhaust gas expanding through a turbine wheel.
- c. Heat Shield - encloses the turbocharger's turbine housing which operates at high temperature. The heat shield contains insulation, but may cause burns if touched during, or immediately after extensive operation of the engine.
- d. Exhaust Pipe - carries the exhaust gases to the flexible connection and on to the exhaust port on the side of the boat at water level. The exhaust gases are cooled by raw water from the raw water cooling system. The raw water enters the exhaust pipe just after the point where gases leave the turbine housing.
- e. Flexible Connection - is a short piece of bellows-type rubber tubing and is used to isolate the engine from the hull.

1-16. FIRE EXTINGUISHING SYSTEM.

- a. Automatic Operated Fire Extinguishers - are located on the underside of each engine compartment hatch. Each extinguisher is equipped with sensor/spray nozzle that operates the extinguisher when subjected to flames or extreme heat.
- b. Hand-Held Fire Extinguisher - is located in bracket, on right side of the forward cockpit. Operating instructions are printed on the extinguisher.

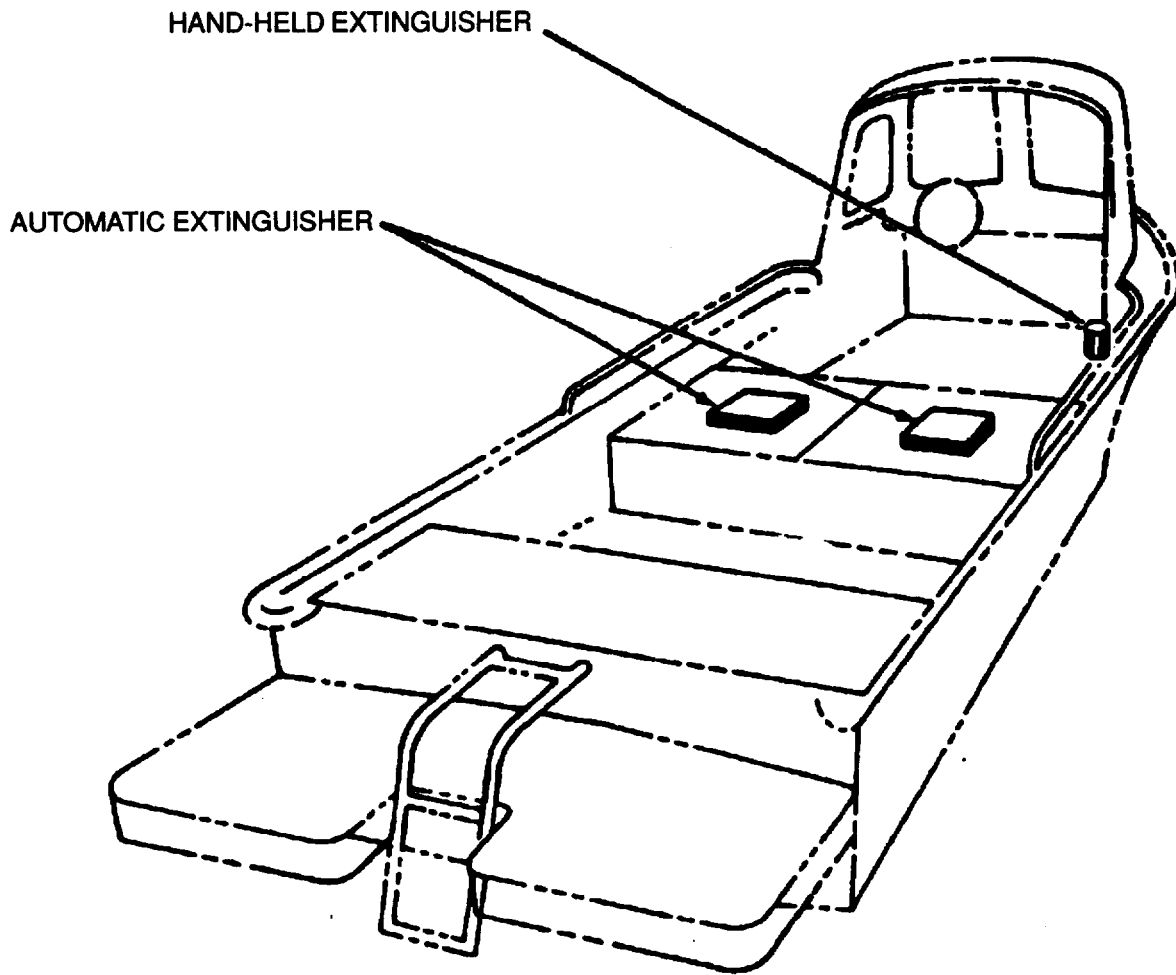

- 1-17. ELECTRIC SYSTEM.** The boat electrical system is 24 vdc. Two 12 volt batteries are connected in series. There are two sets of batteries for power. An alternator is fitted to each engine for charging the batteries. The circuits are arranged so that EITHER alternator can charge EITHER set of batteries automatically. Power is drawn from the batteries by two separate circuits. The batteries on the port side power the starter motor of both engines and the port engine instruments. The batteries on the starboard side power the starboard engine instruments and the auxiliary circuits.
- a. Searchlight - can be located on either the top of the cab (as shown) or on the console when the cab is removed. The searchlight can be used as both a floodlight and spotlight.
 - b. Horn - is located under the console (MK1) or on the front of the forward cockpit (MK2). The horn may be sounded by pressing a button switch on the console.
 - c. Wiper Motors - are located on the inside of the cab above the windshield. The motor operates the windshield wipers in a back-and-forth motion.
 - d. Engine Alarm Mute Switch - allows operator to turn off engine audible alarm that indicates low engine oil pressure or high water temperature.
 - e. Masthead Light - is located on top of the mast and is to be lit when boat is anchored. The light is white.
 - f. Towing Lights - are located at the middle of the mast and are to be lit when the boat is towing. The forward light is white and the stern light is yellow.
 - g. Mast Lights - are located at the middle of the mast and are to be lit when the boat is underway. Both lights are white.
 - h. Side Lights - are located on both sides of the mast. The starboard light is green and the port light is red.

NOTE

The anchor, towing, steaming and navigation lights are not intended for use under combat conditions. They are intended for use in waters subject to boat traffic.

- i. Electric Bilge Pumps - are for pumping out water that has collected inside the hull. One pump is located in the engine compartment and one pump is located in the hydrojet compartment.
- j. Inspection Light - is an extension light located in the engine compartment.
- k. Batteries - are located in the battery compartment and supply the electrical power.
- l. Hour Meters - are located in the battery compartment and record the number of hours the engines are operated.
- m. Emergency Link Solenoid - is located in the battery compartment and is used to connect both pairs of batteries in parallel when additional power is required to start the engines.
- n. Slave Receptacle - is located outside the battery compartment on the starboard side (MK1), or inside the battery compartment (MK2). It is used to slave start the boat when necessary.
- o. Master Battery Switch - is located next to the slave receptacle and turns ON and OFF all electrical power on the boat.
- p. Mast Receptacle and Mast Plug - are located on the starboard side of the boat and supply power to the mast lights.

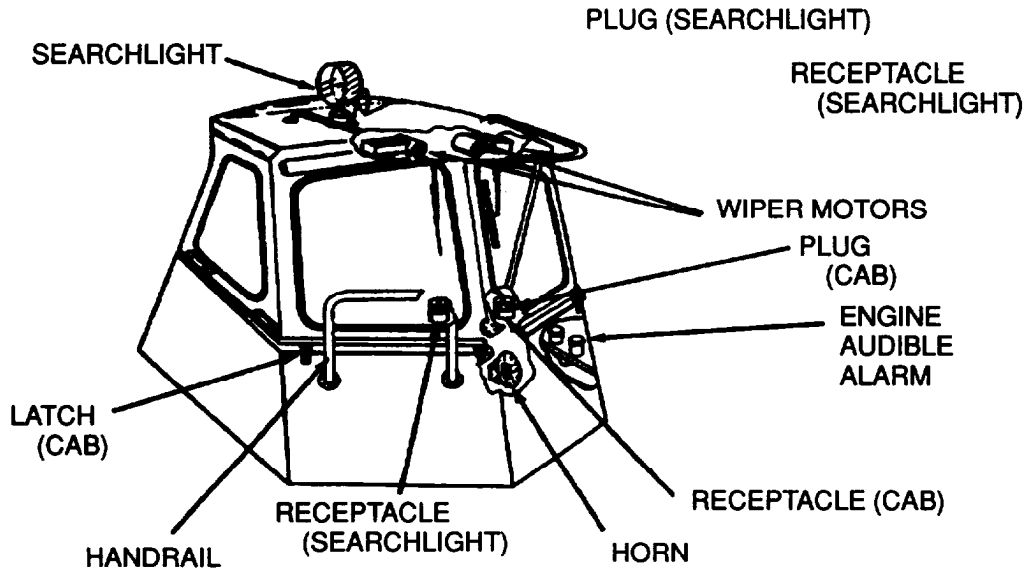

MK 1

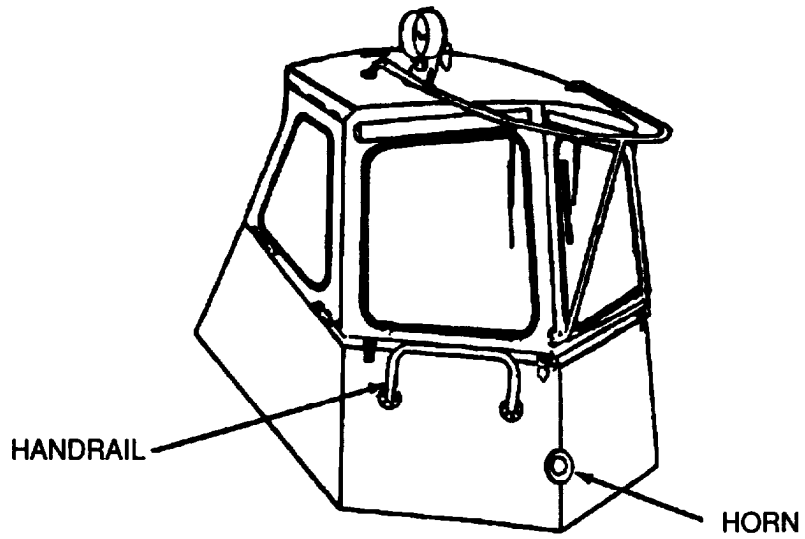

MK 2

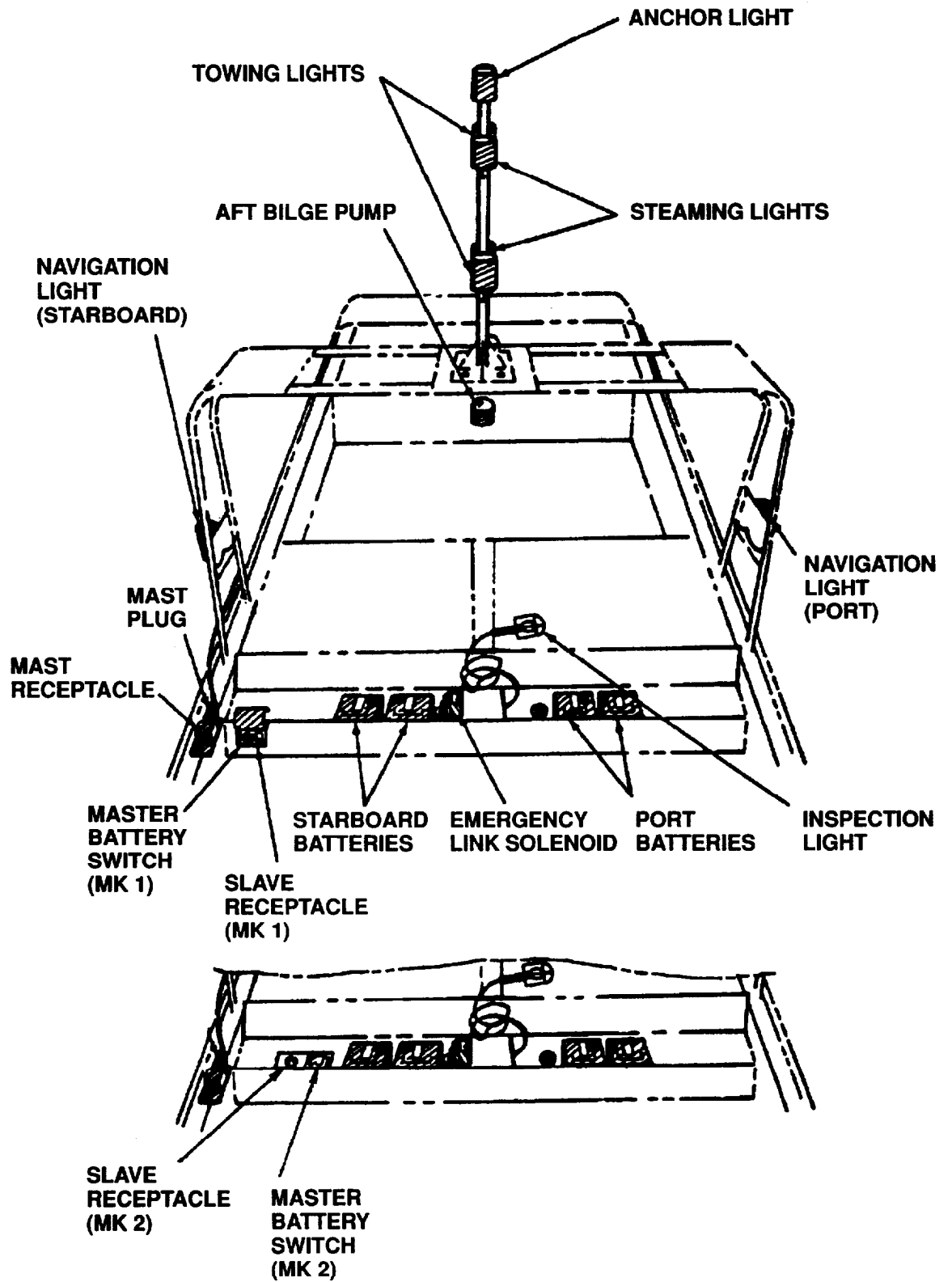

1-18. **ENGINE BREATHING SYSTEM.** Each engine is equipped with a breathing tube located on top of the rocker arm cover. A flexible tube from each engine goes to a central point (trap) where condensed vapors are collected. Non-condensed vapors are vented overboard on the starboard side.

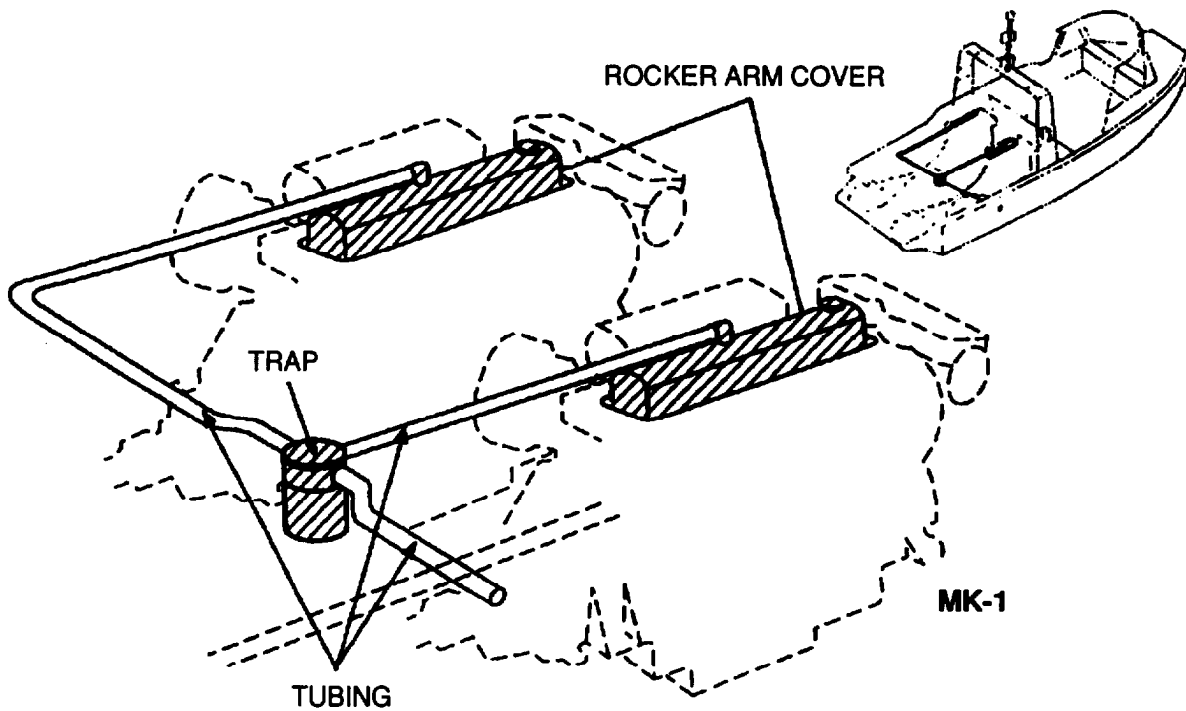
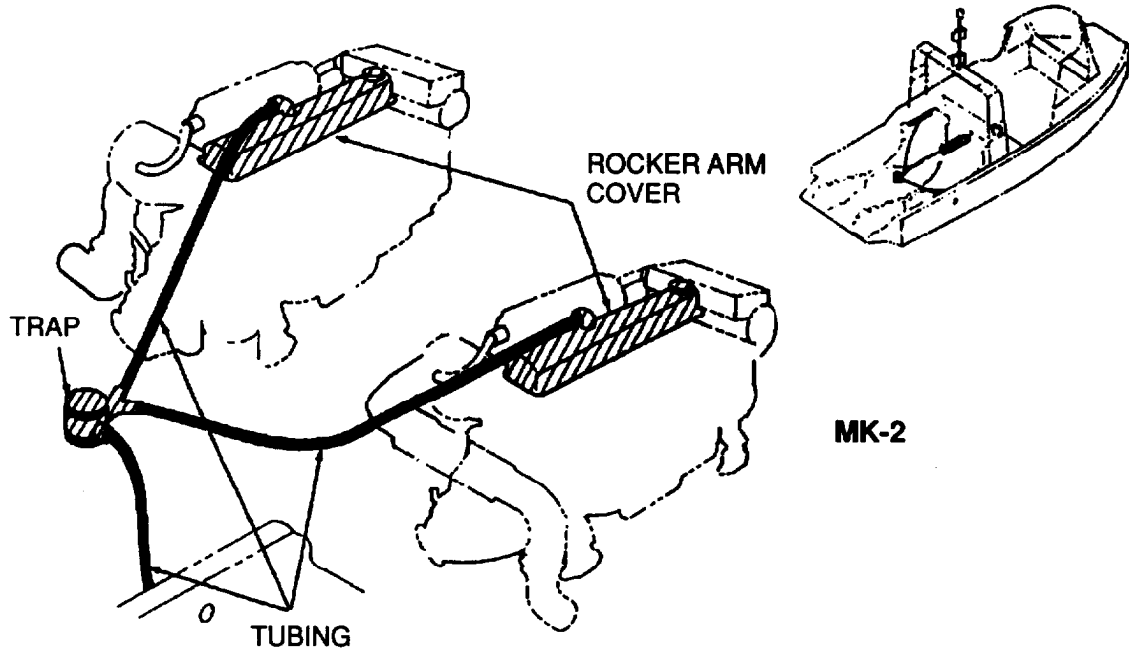

CHAPTER 2

END ITEM MAINTENANCE INSTRUCTIONS

Section I. REPAIR PARTS; SPECIAL TOOLS; TEST MEASUREMENT AND DIAGNOSTIC EQUIPMENT (TMDE); AND SUPPORT EQUIPMENT

- 2-1. COMMON TOOLS AND EQUIPMENT.** For authorized common tools and equipment refer to the Modified Table of Organizational Equipment (MTOE) applicable to your unit.
- 2-2. SPECIAL TOOLS, TMDE AND SUPPORT EQUIPMENT** No special tools, TMDE or support equipment are required for use by unit maintenance personnel. Manufactured items are listed in Appendix D.
- 2-3. REPAIR PARTS.** Repair parts are listed and illustrated in the Repair Parts and Special Tools List TM 5-1940-277-20P covering unit maintenance of this equipment.

Section II. SERVICE UPON RECEIPT

A new Bridge Erection Boat will have been operationally checked prior to leaving the factory. Before operation, drain the shipping/preservation oil from the engines and refill them according to LO 5-1940-277-12/LI 1940-12. The batteries may have to be connected or installed in the boat in accordance with instructions contained in the maintenance procedure portion of this manual. The normal before-operation preventive maintenance checks and services should be performed prior to first operation. Higher level maintenance assistance may be required if any deficiencies are found.

(Refer to TM 5-1940-277-10 for services and checks.)

Section III. PREVENTIVE MAINTENANCE CHECKS AND SERVICES (PMCS)

- 2-4. GENERAL.** To ensure that the boat is ready for operation at all times, it must be inspected to discover and correct defects before they result in serious damage or failure. The preventive maintenance checks and services (PMCS) performed by unit maintenance personnel are listed and described in this section. The item numbers indicate the order of checks and the services based on a logical order of performance.

The interval gives the duration of calendar time between preventive maintenance checks and services. Procedures are required weekly, quarterly, and semiannually. Quarterly and semiannually are based on three and six calendar months respectively.

The item to be inspected or serviced is self-explanatory while the procedure section gives or references the procedure used to inspect or service the item.

The item number column is the source of item numbers for the "TM Number" column on DA Form 2404, Equipment Inspection and Maintenance Worksheet, when recording results of PMCS.

NOTE

Within designated interval, these checks are to be performed in the order listed.

Table 2-1. Unit Preventive Maintenance Checks and Services

Item No.	Interval			Item
	W	Q	S	
				<p>Item to be Inspected Procedure: Check for and have repaired, filed, or adjusted as needed Perform all operator PMCS first</p> <p style="text-align: center;">WARNING</p> <p>When hatch covers are opened, make sure securing latches are installed and latched in place. Before dosing hatch covers, make sure your head and fingers are clear of the opening. Failure to heed this warning may result in death or injury.</p> <p style="text-align: center;">WARNING</p> <p>Do not get acidic water from batteries or battery boxes in eyes or on skin or clothing. This may result in injury. If spilled on personnel, immediately start flushing affected area with clean water and continue until given medical assistance.</p> <p style="text-align: center;">CAUTION</p> <p>Do not get acidic water from batteries or battery boxes on aluminum parts of boat (hull, decks, hatches, etc). This may result in corrosive deterioration of aluminum parts.</p> <p style="text-align: center;">CAUTION</p> <p>Charge batteries for 1 hour after adding water when temperatures may go below freezing 32°F (0°C).</p> <p style="text-align: center;">NOTE</p> <p>To ensure readiness of a boat placed in storage, you should maintain the batteries at a full charge, perform all the PMCS quarterly, launch the boat, and check the systems/components for proper operation.</p>

Table 2-1. Unit Preventive Maintenance Checks and Services (cont)

Item No.	Interval			Item to be Inspected Procedure: Check for and have repaired, filed, or adjusted as needed Perform all operator PMCS first
	W	Q	S	

1

•

BATTERIES AND BATTERY BOXES

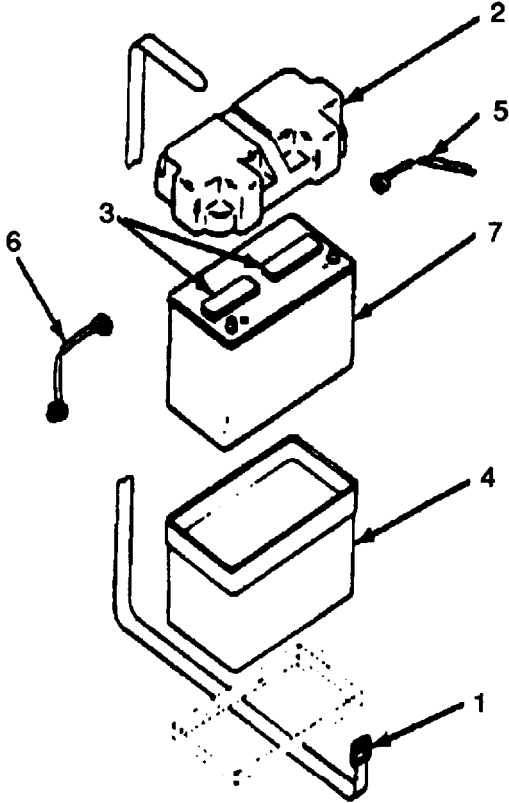

- a. Battery water levels. Open and secure battery compartment hatch. Remove battery box tie-down straps (1) battery box covers (2) and fill caps (3) from battery cells. Check for proper water level in cells. Proper water level is 3/8 inch (9.5 mm) above plates. If water level is less than 3/8 inch (9.5 mm), add clean, deair water (distilled water is preferred) and install fill cape. Check for and remove corrosion.

CAUTION

Do not set batteries on deck, hatches, or boat. This may result in corrosive deterioration of boat aluminum.

- b. Water accumulation in battery boxes. Check inside of battery boxes (4) for water. If water is found, disconnect negative cable (5) and then positive cable (6) from battery (7) and remove battery. Do not set batteries down on the boat. Remove battery box and property dispose of acidic water. Clean and wipe box dry. Install battery box, battery, battery cables, cover (2), and tiedown straps (1). Close compartment hatch.

Table 2-1. Unit Preventive Maintenance Checks and Services (cont)

W-Weekly

Q-Quarterly

S-Semiannually

Item No.	Interval			Item	Item to be inspected Procedure: Check for and have repaired, filed, or adjusted as needed Perform all operator PMCS first
	W	Q	S		
2	•			<u>RAW WATER PUMPS.</u>	 <p style="text-align: center;">NOTE</p> <p>If there are pieces of rubber missing from impeller they will have to be removed from the inlet end cover and tube stack of the header tank heat exchanger.</p> <p>a. Pump impellers. Open and secure engine hatches. Remove draindown tubing (1), six screws (2), cover (3), cover gasket (4), and rubber button (5). Use two screwdrivers (6) and remove impeller. Check impeller (7) for wear, signs of overheating, and deterioration. Bend vanes back and check for cracked or broken vanes.</p> <p style="text-align: center;">CAUTION</p> <p>Self-priming ability of pump is reduced by the amount of wear in pump parts. If pump is run dry more than 30 seconds it could overheat and bum the impeller.</p> <p>b. Pump housing. Check cover (3) and the cam and wear plate inside housing (8) for indications of overheating and wear. Lubricate impeller (7), with liquid soap, rotate it in the direction of rotation, and push it on the shaft and into the housing. install rubber button (3). Apply sealant to cover gasket (4). Install gasket, cover, screws (2), and rain-down tubing (1).</p>

Table 2-1. Unit Preventive Maintenance Checks and Services (cont)

Item No.	Interval			Item	Item to be Inspected Procedure: Check for and have repaired, filed, or adjusted as needed Perform all operator PMCS first
	W	Q	S		
3		•		<u>BOAT ASSEMBLY</u>	

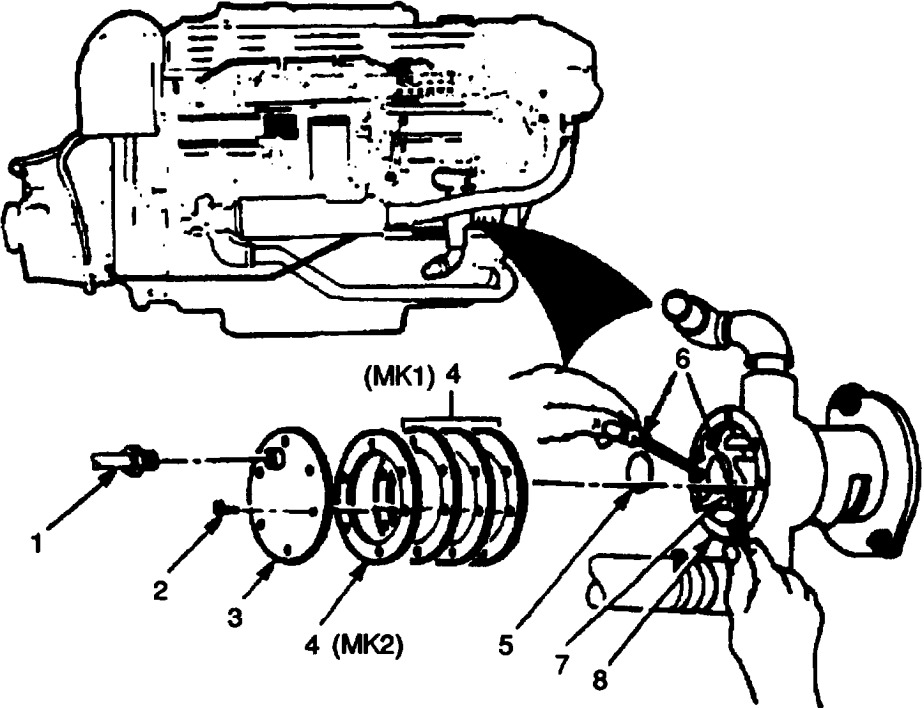
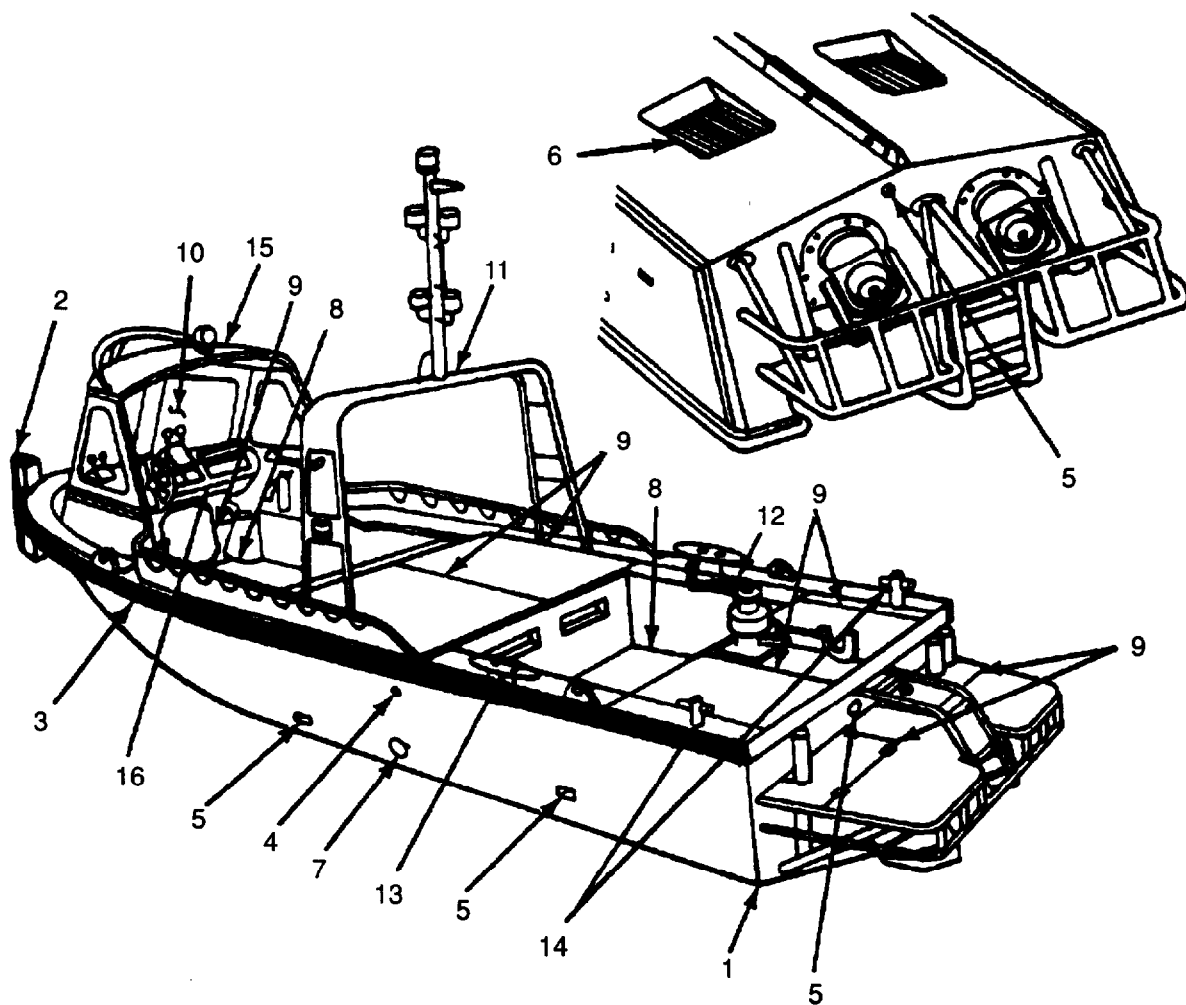

NOTE

If structural damage has occurred to the outside of the hull, inspect the inside of the hull for damage.

- a. Hull (1), pushknees (2), rub rails (3), vent (4), drains (5), intakes (6) and exhausts (7), decks (8), hatches (9), cockpits (10), mast (11), capstan (12), cleats (13), bollard (14). Check for structural damage (cracked or broken welds; missing, bent, cracked, twisted, crushed, or torn metal; holes through skin; etc). Check that pushknees and rub rails are properly attached and not torn or missing. Check that capstan operates without drag or binding and is securely mounted. Check for loose, broken, or missing hardware.
- b. Cab (15). Check for structural damage. Check that handrails, latches, windows, and windshield wipers are securely mounted and not missing or damaged. Check wiper blade condition and operation of wiper system. Check for loose, broken, or missing hardware.

Table 2-1. Unit Preventive Maintenance Checks and Services (cont)

W-Weekly

Q-Quarterly

S-Semiannually

Item No.	Interval			Item	Item to be Inspected Procedure: Check for and have repaired, filed, or adjusted as needed Perform all operator PMCS first
	W	Q	S		

3
(cont)

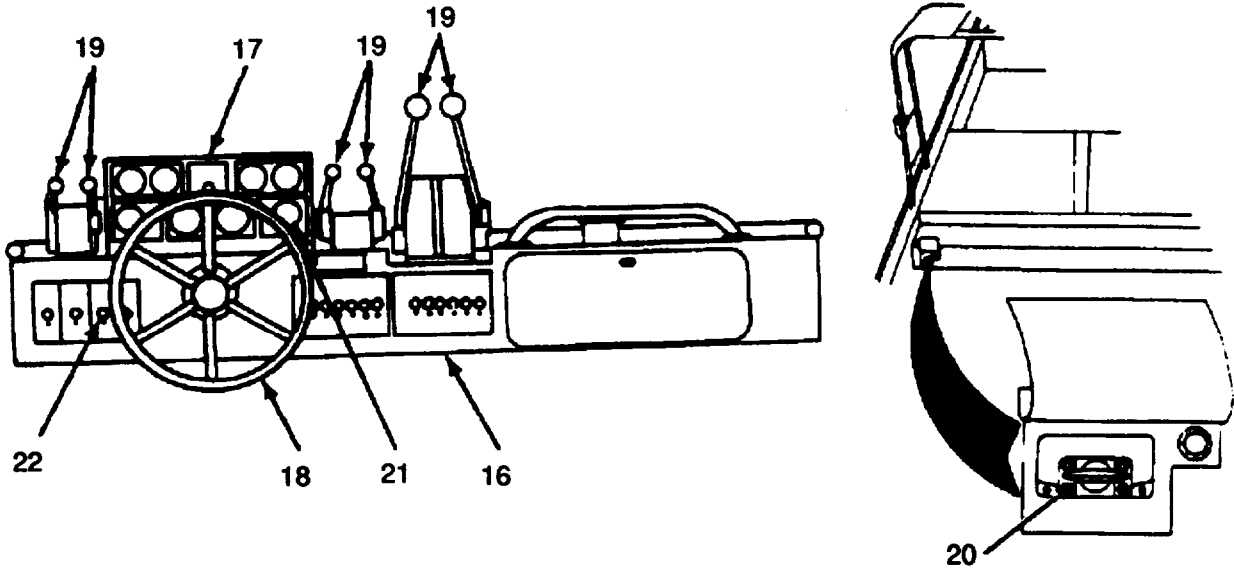

- c. Console (16), instrument panel (17), steering (18), and controls (19). Check for structural damage and for loose or missing parts. Check that steering and control levers operate without drag or binding. Check that controls and their cables operate properly and are properly adjusted. With batteries installed, turn on battery master switch (20) and check that auxiliaries voltmeter (21) indicates above 24 volts. Check that cabin, inspection, anchor, towing, search, and navigation lights are in their proper locations and not broken. Press horn switch (22) and check that horn operates. Check for loose, broken, or missing hardware and replace torn or missing rubber switch boots.

4

FUEL SYSTEM.

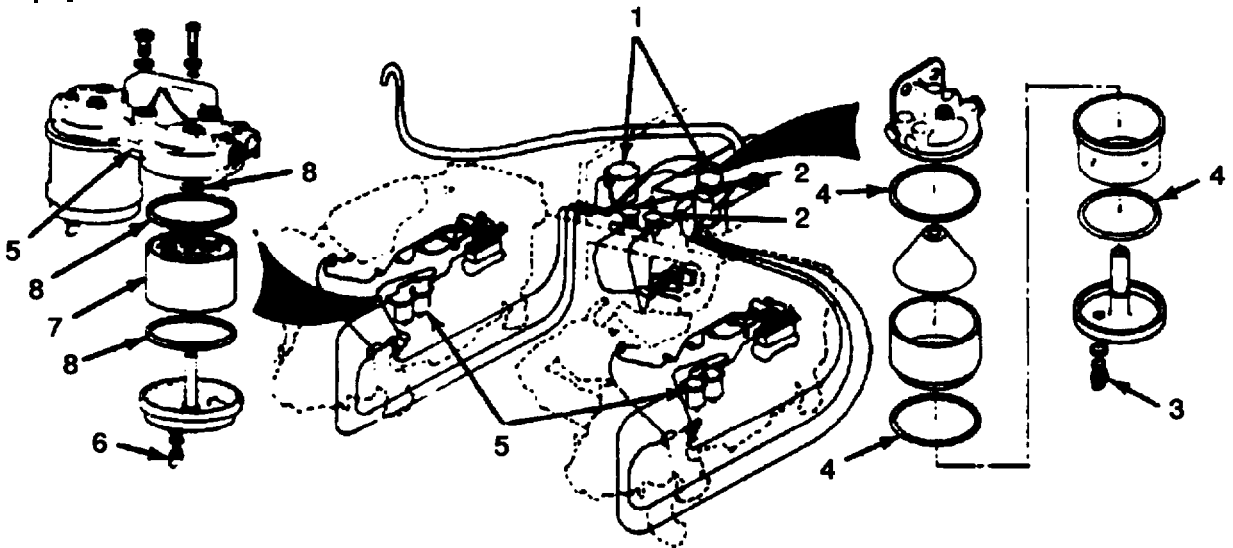

Table 2-1. Unit Preventive Maintenance Checks and Services (cont)

Item No.	Interval			Item	Item to be Inspected Procedure: Check for and have repaired, filed, or adjusted as needed Perform all operator PMCS first
	W	Q	S		
(cont)					<div style="text-align: center; border: 1px solid black; padding: 5px; width: fit-content; margin: 0 auto;"> WARNING </div> <p>Do not allow fuel to enter the bilges. Fuel is flammable and could explode.</p> <ul style="list-style-type: none"> a. Fuel water separator filter (1). Open engine and battery compartment hatches and secure them. Close off two fuel shutoff valves (2). Loosen drain plug (3) in the bottom of the fuel water separator filters and drain contents of filters into a suitable container. Do not drain contents of filters into the bilges. Disassemble filters and clean and inspect for damage. Install new gaskets (4) and assemble filters. Clean up spilled fuel. b. Fuel filter (5) (on engines). Remove drain plug (6) from bottom of fuel filters and drain contents of filter into a suitable container. Do not drain filters into the bilges. Disassemble filters and clean and inspect for damage. Install new filter elements (7) and gaskets (8) and assemble the filters. Clean up spilled fuel. Open the two fuel shutoff valves and bleed fuel system. Check for and correct fuel leaks. c. Fuel feed and return lines, valves, pumps, and vent. Check for fuel leaks, loose connections, and crushed or kinked lines and hoses.
5				<p><u>SILENCERS AND AIR FILTERS.</u></p>  <p>a. Silencer assemblies (1). Remove silencer assembly from the turbocharger. Remove silencer (2) and air filter (3) from cover (4). Check for missing, cracked, or crushed parts.</p>	

Table 2-1. Unit Preventive Maintenance Checks and Services (cont)

W-Weekly

Q-Quarterly

S-Semiannually

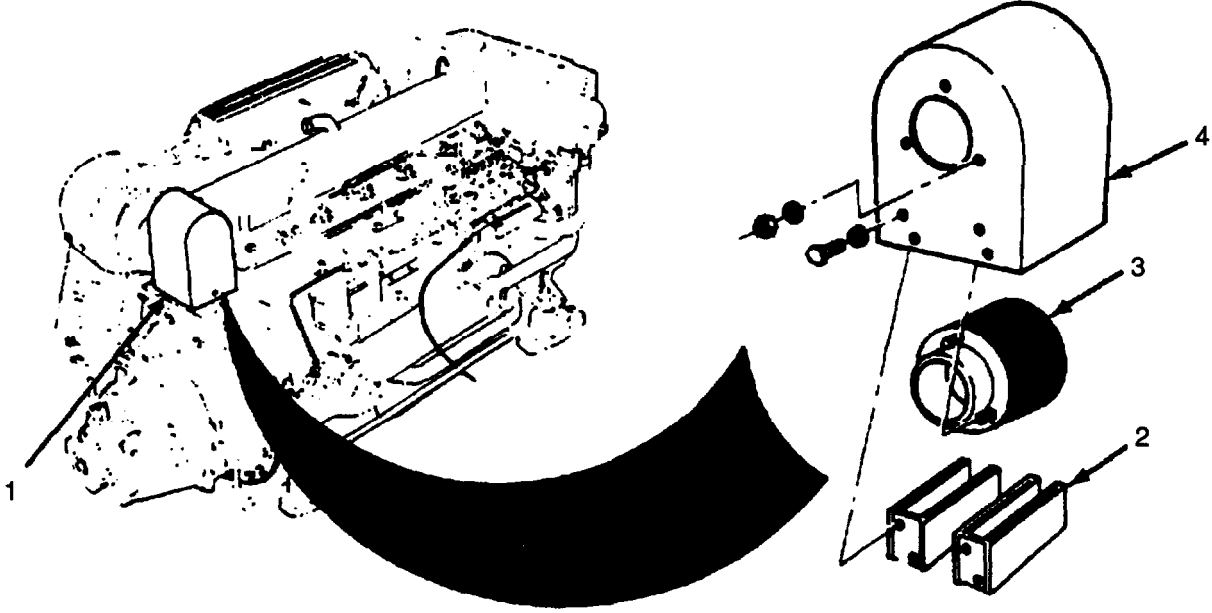
Item No.	Interval			Item	Item to be Inspected Procedure: Check for and have repaired, filed, or adjusted as needed Perform all operator PMCS first
	W	Q	S		
5 (cont)		•		b. Air filter assembly (3). Clean air filter, silencer, and cover in a detergent-water solution, rinse in fresh water, and dry. Repair or replace loose or missing sponge rubber. Install air filter and silencer in cover and install silencer assemblies on the turbochargers.	
6		•		<u>ENGINE BREATHER SYSTEM.</u>	
				 <p>The diagram illustrates the engine breather system. It features a cylindrical breather trap (2) with a gasket (3) at its base. A network of breather tubing (1) is connected to the trap and extends to two turbochargers, which are shown in dashed outlines. The tubing is secured with clamps and passes through various components of the engine compartment.</p>	
				a. Breather Tubing (1). Check for leaks and loose or missing clamps. Check if tubing is kinked, crushed, torn, or missing. Check for loose or missing hardware.	
				b. Breather trap (2). Disassemble, clean, and inspect for damage. Install new gaskets (3) and assemble.	

Table 2-1. Unit Preventive Maintenance Checks and Services (cont)

Item No.	Interval			Item	Item to be Inspected Procedure: Check for and have repaired, filed, or adjusted as needed Perform all operator PMCS first
	W	Q	S		
7		•		<u>ENGINE COOLING SYSTEMS (MK1).</u>	 <p>MK1</p> <ol style="list-style-type: none"> Raw water system (1). Check for leaks and loose clamps. Check for worn, cracked, twisted, crushed, or missing hoses and tubing. Check for loose or missing hardware. Engine coolant system (2). Check for leaks and loose clamps. Check for worn, cracked, twisted, crushed, or missing hoses and tubing. Check for loose and missing hardware.
8		•		<u>ENGINE ASSEMBLIES.</u>	 <ol style="list-style-type: none"> Port and starboard engines (1). Check for fuel, oil, coolant, and raw water leaks. Check for loose, broken, or missing hardware and components. Check intake and exhaust systems for leaks, loose clamps, damaged hoses, and missing hardware.

Table 2-1. Unit Preventive Maintenance Checks and Services (cont)

Item No.	Interval			Item
	W	Q	S	
8 (cont)		•		<p>Item to be Inspected Procedure: Check for and have repaired, filed, or adjusted as needed Perform all operator PMCS first</p> <p>b. Engine wiring (2). Check for loose, burnt, worn, or broken wires, insulation, and connections. Check that connectors are tight and not broken. Check that engine safety switch connections are properly installed and tight.</p> <p>c. Engine V-belts.</p> <div style="text-align: center;">  </div> <p style="text-align: center;">CAUTION</p> <p>Loose V-belts can overheat or slip off the drive pulley, causing premature belt or engine failure. Overtightened V-belts may cause premature belt or bearing failure.</p> <p>(1) V-belt (3) adjustment. Check adjustment by applying moderate hand pressure at center of V-belt between water pump pulley (4) and alternator pulley (5). Obtain a deflection of between 1/4 and 1/8 inch (6.4 and 3.2 mm). To decrease tension, unlock T-handle adjuster lock (6) and turn T-handle adjuster (7) clockwise. To increase tension, turn T-handle adjuster counterclockwise. Ensure alternator mounting bolts are tight.</p> <p>(2) V-belt (3) check. Check if belts are worn, burnt, cracked, broken, or missing.</p> <p>d. Fuel injection pump (8). Check that engine idle is adjusted to between 650 and 750 rpm. Check for proper adjustment of throttle and stop cables. Check for fuel and oil leaks and for loose or missing hardware.</p> <p>e. Engine motor mounts (9). Check that engine mounting bracket bolts are tight and not missing. Torque the eight nuts on motor mounts to 32.5±5 lb-ft (44±7 NŹm).</p> <p>f. Transmissions (10). Check for oil leaks. Check for proper adjustment of shift cable and for loose or missing hardware.</p>

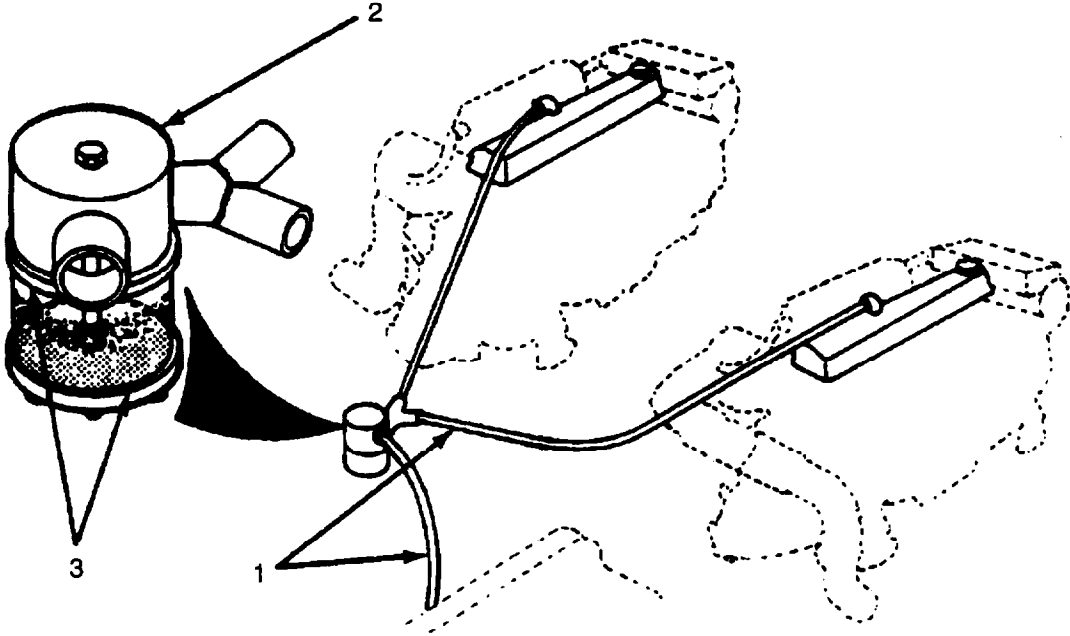
Table 2-1. Unit Preventive Maintenance Checks and Services (cont)

Item No.	Interval			Item to be Inspected Procedure: Check for and have repaired, filed, or adjusted as needed Perform all operator PMCS first
	W	Q	S	
9		•		<p><u>DRIVE LINE ASSEMBLIES.</u></p>  <p>The diagram shows a side view of a vehicle chassis. Callout 2 points to the aft cockpit area. Callout 1 points to the drive shaft. Callout 3 points to the U-joints at both ends of the drive shaft. Callout 4 points to the drive shaft collar and support.</p> <ol style="list-style-type: none"> Drive lines (1). Remove aft cockpit (2) and check drive lines for loose or worn U-joints (3). Check that U-joint mounting bolts are tight and not missing. Drive shaft collar and support (4). Check that bolts are tight and that bolts and spacers are not missing.

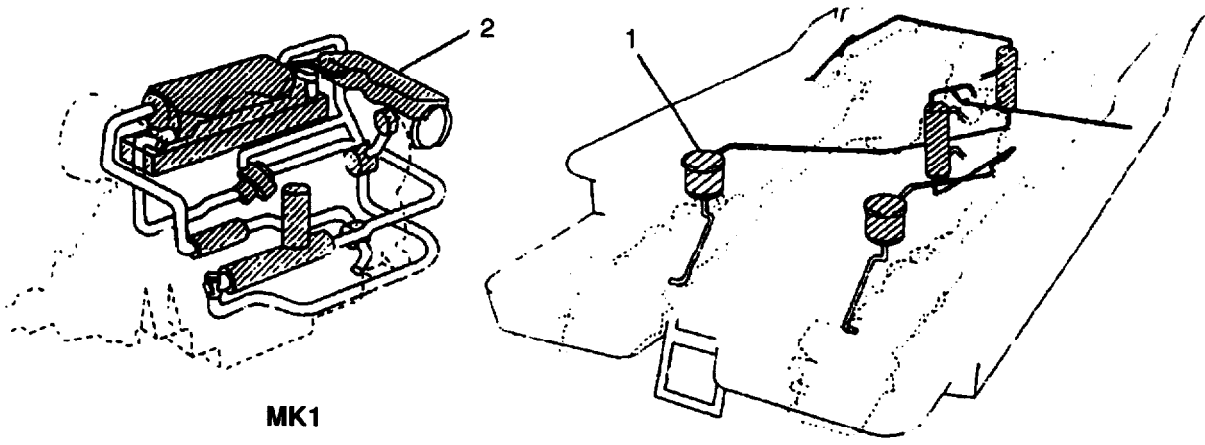
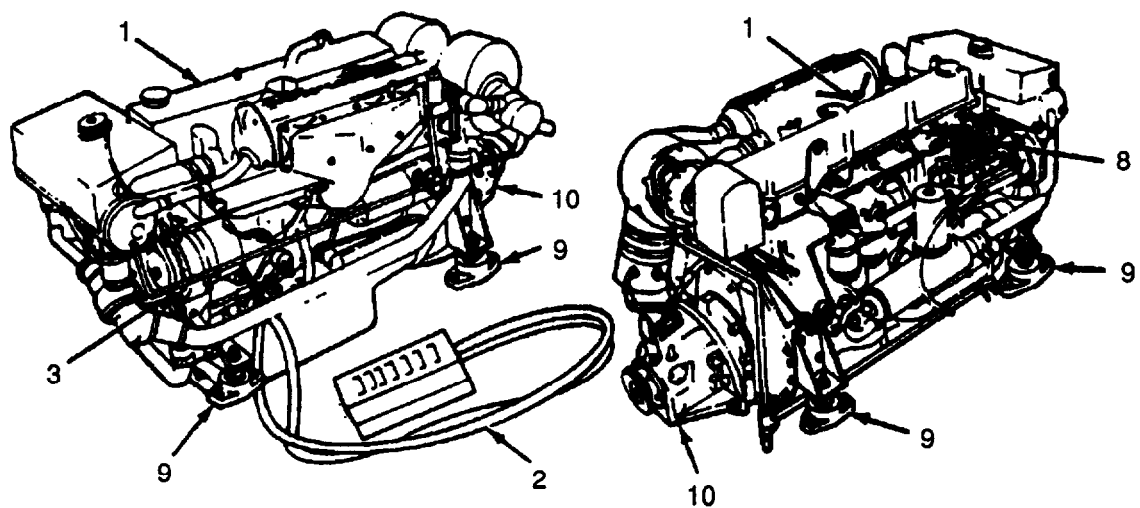
Table 2-1. Unit Preventive Maintenance Checks and Services (cont)

Item No.	Interval			Item
	W	Q	S	
				<p>Item to be Inspected Procedure: Check for and have repaired, filed, or adjusted as needed Perform all operator PMCS first</p> <p><u>HYDROJET AND STEERING ASSEMBLIES.</u></p>  <p>Do not operate engines while inspecting hydrojet assemblies. Failure to heed this warning may result in injury.</p> <ol style="list-style-type: none"> a. Hydrojet assemblies (1). Loosen inspection cover wingnuts (2) and remove the cover (3). Rotate impeller drive shaft and check if impeller blades or shaft is bent, cracked, or broken. Remove debris. Install inspection cover and gasket, tighten wingnuts, and check for leaks. b. Steering nozzle (4) and reversing scoop (6) assemblies. <ol style="list-style-type: none"> (1) Check for loose, bent, worn, or missing linkages. Check for loose, worn or missing hardware. Check for cracked, bent, or broken steering nozzle (4) or steering components (5). Rotate steering nozzles from stop to stop and adjust them so they rotate in unison and contact their stop at the same time. (2) Check for loose, bent, cracked, or broken reversing scoop (6) or cover (7). Check for loose, worn, or missing brush assembly. Pull reversing scoop control levers to the full reverse position and adjust the scoops so that the upper edge is even with the reversing indicator attached to the steering nozzle. Push reversing scoop control levers to full forward position and check that reversing scoops engage their stops. If stops are not engaged, adjust linkages, rotary control, or cables.

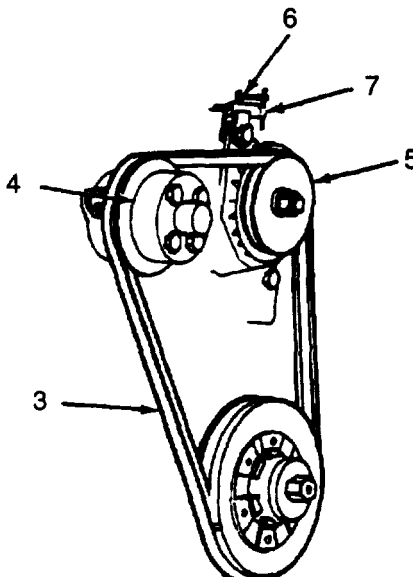
Table 2-1. Unit Preventive Maintenance Checks and Services (cont)

Item No.	Interval			Item to be Inspected Procedure: Check for and have repaired, filed, or adjusted as needed Perform all operator PMCS first
	W	Q	S	
11			•	<p>BILGE PUMPS.</p>  <p>a. Electric bilge pumps (1). Open and secure engine and hydrojet hatch covers. Remove four mounting bolts (2) and the two bilge pumps with mounting brackets (3). Remove four screws securing the screens and remove the screens. Clean and inspect screens. If screens are damaged or broken, replace them. Check for damaged or dogged pump impellers. Assemble and install pumps. Check the pumps for proper operation and output. Check the system for leaks.</p> <p>b. Hand bilge pump (4). Open stowage locker. From inside stowage locker, remove bilge pump top cover and check inside pump for a dogged or damaged diaphragm. Install top cover, operate pump, and check for proper operation and output. Check the system for leaks.</p>

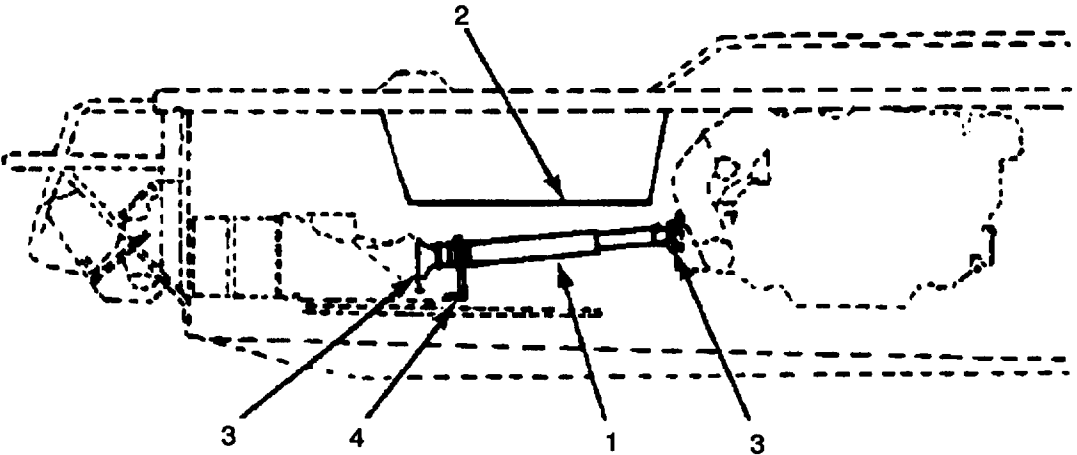
Table 2-1. Unit Preventive Maintenance Checks and Services (cont)

Item No.	Interval			Item	Item to be Inspected Procedure: Check for and have repaired, filed, or adjusted as needed Perform all operator PMCS first
	W	Q	S		
12				ANODES.	<p>a. Hydrojet tail cone anode (1). Check for loose bolts or nuts (2). Replace anode if pitting is through anode or if anode is over 50 percent deteriorated (worn down).</p> <p>b. Keel anodes (3). Check for loose or missing bolts (4). Replace if pitting is through anode or if anode is over 50 percent deteriorated (worn down).</p>

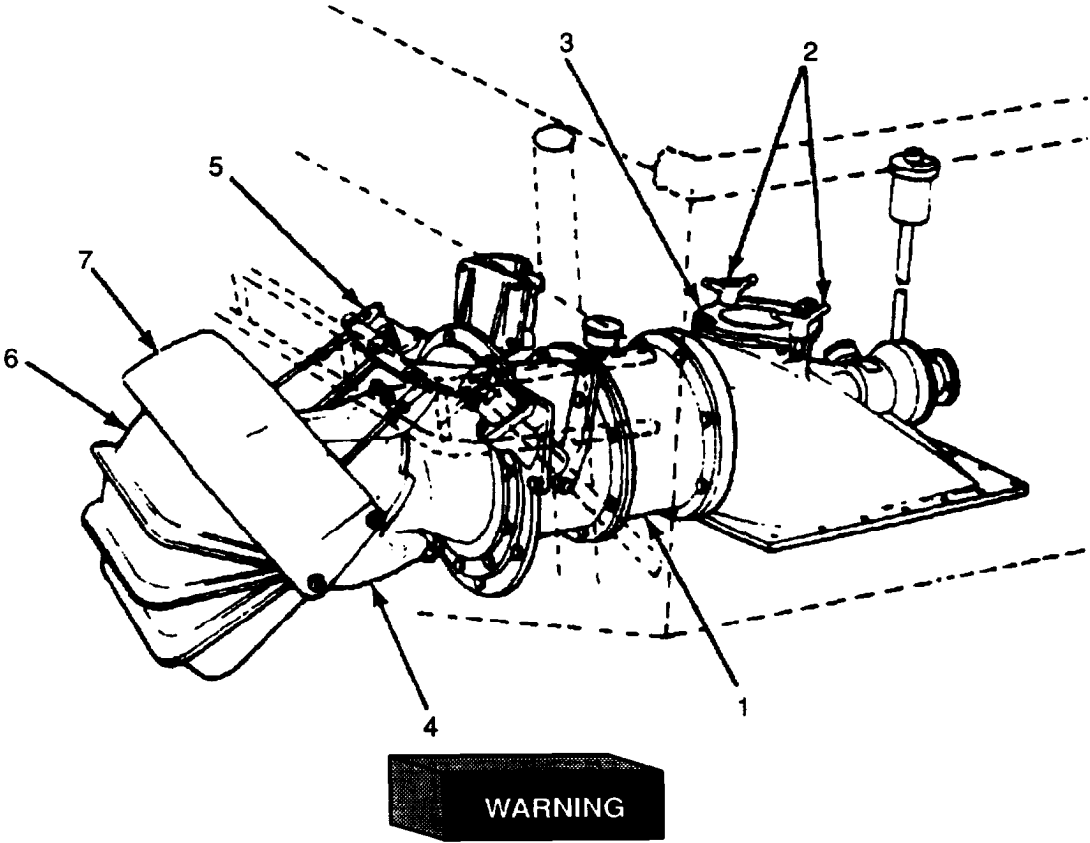
Table 2-1. Unit Preventive Maintenance Checks and Services (cont)

Item No.	Interval			Item	Item to be Inspected Procedure: Check for and have repaired, filed, or adjusted as needed Perform all operator PMCS first
	W	Q	S		
13			●	BOAT ELECTRICAL SYSTEM	 <p>a. Electrical system (1). Open panels and remove covers to expose electrical connections, wires, wire harnesses, and cable assemblies in cab, instrument panel, mast, battery, and engine compartments.</p> <p>(1) Check for loose, missing, burnt, corroded, cracked, or broken terminals and/or connectors.</p> <p>(2) Check for worn through, cut, tom, burnt, broken, cracked, or missing wires, wire insulation, and cable harness assemblies.</p> <p>b. Operate electrical switches and buttons and check that associated lights and motors operate property.</p> <p>c. Check that lights and lenses are properly located and are mounted securely.</p>

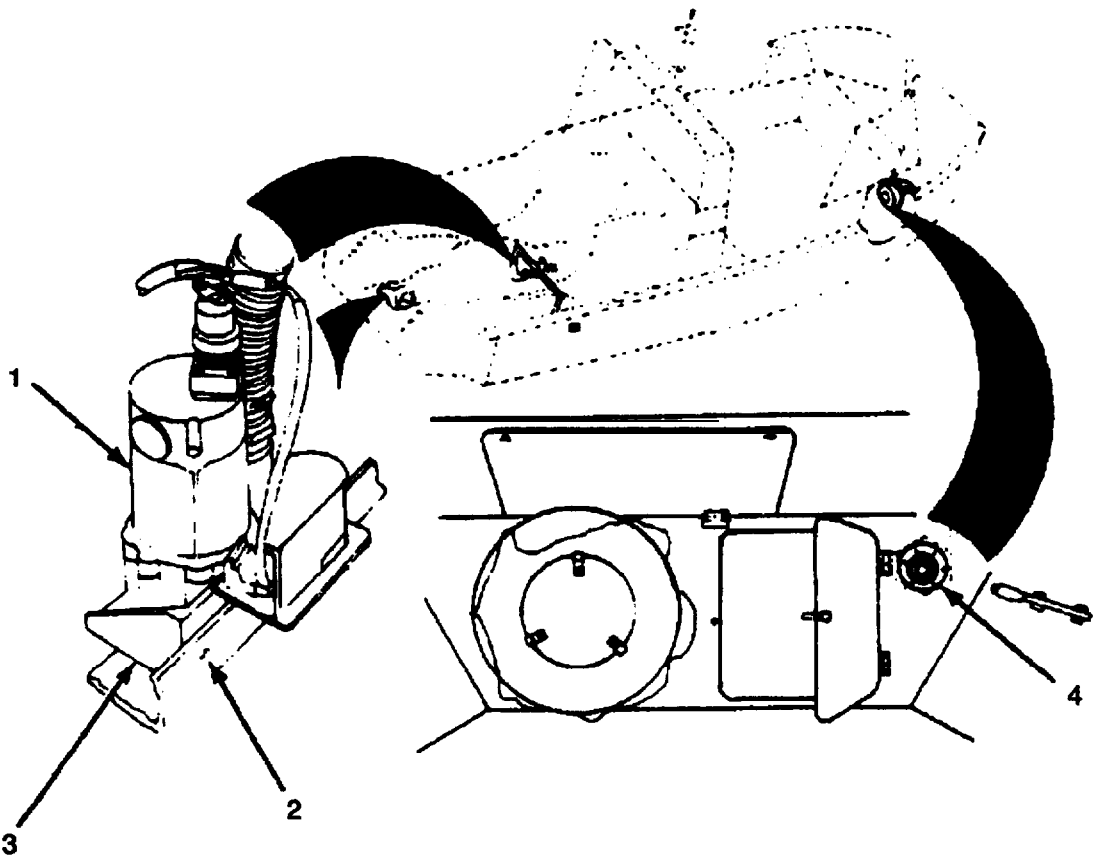
Table 2-1. Unit Preventive Maintenance Checks and Services (cont)

W-Weekly Q-Quarterly S-Semiannually

Item No.	Interval			Item	Item to be Inspected Procedure: Check for and have repaired, filed, or adjusted as needed Perform all operator PMCS first
	W	Q	S		
14			•	FUEL INJECTORS.	
				a. Operate engines and check for proper operation of fuel injectors. Missing, rough running, or lack of power may indicate a defective injector or injectors. Replace suspected defective fuel injectors.	
				b. Sometimes defective injectors can be detected by feeling for vibration in the fuel injector feed lines. All lines should feel the same. If a definite difference can be detected between two lines, the one with more pronounced vibration can indicate a defective injector.	
15			•	VALVE LIFTERS.	
				a. Operate engines and listen for proper operation and adjustment of valve lifters. A clattering, clicking, or knocking sound from under valve cover is an indication that valves required adjustment. A rough running engine may be an indication that valve lifters are too tight.	
				b. Adjust valve clearances as follows:	
				(1) Turn engine over until valve to be adjusted is fully closed and its cam lobe is to the bottom of its stroke.	
				(2) If engine is hot, use a 0.018-inch (0.45 mm) feeler gage. With engine cold, place a 0.019-inch (0.48 mm) feeler gage between rocker arm and valve stem. Loosen locknut and turn adjusting screw clockwise to decrease valve lash or counterclockwise to increase valve lash. Proper adjustment is when feeler gage has a slight drag when moved between valve stem and tip of rocker arm.	

Section IV. TROUBLESHOOTING

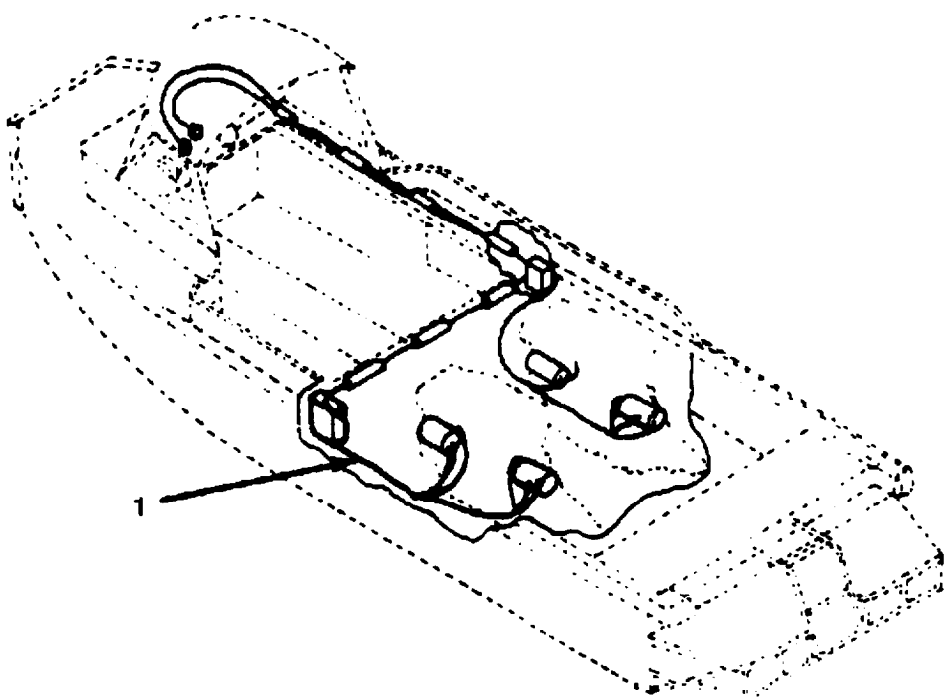
2-5. INTRODUCTION. This section tells you how to find and fix most things that go wrong with the boat. Malfunctions which might occur are listed followed by the check, test, or inspection of the probable cause. The corrective action recommended for the probable cause is then described. Do all checks, tests, inspections and corrective actions in the order listed. After you complete a corrective action operate the equipment to see if the malfunction has been eliminated. If the malfunction continues, go on to the next step.

This manual cannot list all malfunctions that may occur, or all checks, tests, inspections and corrective actions possible. If a malfunction is not listed, or is not corrected by the corrective actions listed, notify your supervisor.

MALFUNCTION

TEST OR INSPECTION

CORRECTIVE ACTION

1. ENGINE FAILS TO CRANK WHEN START SWITCH ENGAGED.

- Step 1. Check position of master battery switch (refer to paragraph 1-17).
- a. Set master battery switch "ON".

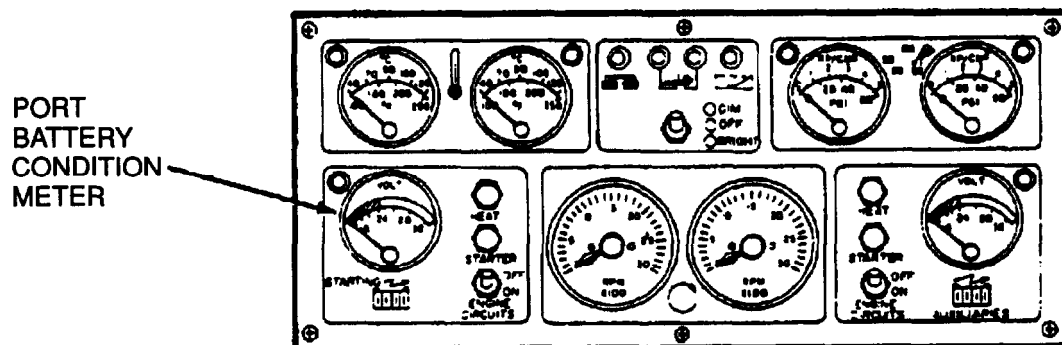

- Step 2. Check port battery condition meter reading.
 - a. If below 24 vdc go to Step 4.
- Step 3. Check battery connections and cables (refer to paragraph 3-90).
 - a. Clean and tighten connections (refer to paragraph 3-90).
 - b. Replace defective cables (refer to paragraph 3-90).
- Step 4. Test batteries (refer to paragraph 3-88).
 - a. Replace defective battery (refer to paragraph 3-89).
- Step 5. Test master switch (refer to paragraph 3-100).
 - a. Replace defective master switch (refer to paragraph 3-100).
 - b. Report defective control box to direct support maintenance (refer to paragraph 3-110).
- Step 6. Test engine start switch.
 - a. Replace defective start switch.

Section IV. TROUBLESHOOTING (Continued)

MALFUNCTION

TEST OR INSPECTION

CORRECTIVE ACTION

1. ENGINE FAILS TO CRANK WHEN START SWITCH ENGAGED - Continued.

- Step 7. Test master switch (refer to paragraph 3-100).
- a. Replace defective starter (refer to paragraph 3-121).
- Step 8. Inspect flywheel and ring gear (refer to paragraph 3-130).
- a. Report defective flywheel or ring gear to supervisor.

2. ENGINE CRANKS BUT FAILS TO START.

- Step 1. Check position of engine stop control (refer to paragraph 3-41).
- a. Push in fully and insure that stop control cable is not broken and is connected at the injection pump (refer to paragraph 3-41).

WARNING

- Set master switch to "OFF".
- No smoking.

NOTE

Whenever fuel system is opened bleed the system of air.

- Step 2. Check for fuel in fuel tank.
- a. Refuel if empty.
 - b. Bleed the fuel system after refueling (refer to paragraph 3-64).
- Step 3. Check position of fuel master shutoff valve (refer to paragraph 3-59).
- a. Open master shutoff valve.
 - b. Replace defective master shutoff valve (refer to paragraph 3-59).
- Step 4. Check position of engine shutoff valve (refer to paragraph 3-58).
- a. Open engine shutoff valve.
 - b. Replace defective engine shutoff valve.
- Step 5. Check fuel hoses and lines for leaks (refer to paragraph 3-57).
- a. Tighten leaking connections.
 - b. Replace defective lines (refer to paragraph 3-57).
- Step 6. Check for air in fuel system (refer to paragraph 3-64).
- a. Bleed air (refer to paragraph 3-64).
- Step 7. Inspect fuel filter.
- a. Replace defective fuel filter (refer to paragraph 3-62).
- Step 8. Test fuel lift pump.
- a. Replace defective fuel lift pump (refer to paragraph 3-63).

Section IV. TROUBLESHOOTING (Continued)

MALFUNCTION

TEST OR INSPECTION

CORRECTIVE ACTION

2. ENGINE CRANKS BUT FAILS TO START - Continued.

Step 9. Inspect engine throttle cable.

- a. Replace defective engine throttle cable (refer to paragraph 3-39).

Step 10. Check engine stop control cable.

- a. Replace defective engine stop control cable (refer to paragraph 3-41).

3. ENGINE CRANKS SLOWLY (NORMAL START ATTEMPT).

Step 1. Check starting battery charge using port battery condition meter.

- a. Connect emergency link and start engine.

Step 2. Check engine transmission control setting (refer to paragraph 3-37).

- a. Set transmission control in neutral (refer to paragraph 3-37).

Step 3. Check transmission control linkage.

- a. Adjust transmission control linkage.

4. ENGINE STARTS BUT FAILS TO KEEP RUNNING.



No smoking.

Step 1. Check fuel hoses and lines for leaks.

- a. Tighten leaking connections.
- b. Replace defective hoses and lines.
- c. Bleed fuel system (refer to paragraph 3-64).

Step 2. Check sedimenter for water (refer to paragraph 3-61).

- a. Drain water and sediment (refer to paragraph 3-61).

Step 3. Check fuel filter (refer to paragraph 3-62).

- a. Replace defective fuel filter (refer to paragraph 3-62).

Step 4. Check engine control cables and linkages.

- a. Adjust engine control cable and linkages (refer to paragraph 3-39).
- b. Replace defective engine control cables and linkages (refer to paragraph 3-39).

Step 5. Inspect throttle control head assembly for looseness, disconnection, or damage.

- a. Repair throttle control head assembly (refer to paragraph 3-33).
- b. Replace defective throttle control head assembly (refer to paragraph 3-34).

Step 6. Inspect injector lines and fittings

- a. Replace defective injector lines and fittings (refer to paragraph 3-124).

Section IV. TROUBLESHOOTING (Continued)

MALFUNCTION

TEST OR INSPECTION

CORRECTIVE ACTION

5. ENGINE STARTS BUT MISFIRES AND RUNS ROUGH.

Step 1. Check valve adjustment (refer to paragraph 3-128).

a. Adjust valves (refer to paragraph 3-128).

6. ENGINE DOES NOT DEVELOP FULL POWER.

Step 1. Check air filter (refer to paragraph 3-133).

a. Clean air filter (refer to paragraph 3-133).

b. Replace air filter (refer to paragraph 3-133).

Step 2. Check turbocharger (refer to paragraph 3-123).

Step 3. Inspect throttle control head assembly for looseness, disconnection, or damage.

a. Repair throttle control head assembly (refer to paragraph 3-33).

b. Replace defective throttle control head assembly (refer to paragraph 3-34).

Step 4. Inspect engine throttle cable.

Step 5. Disengage transmission and check engine response.

7. ENGINE OVERHEATS (ENGINE AUDIBLE ALARM ACTIVATES).

a. MK1

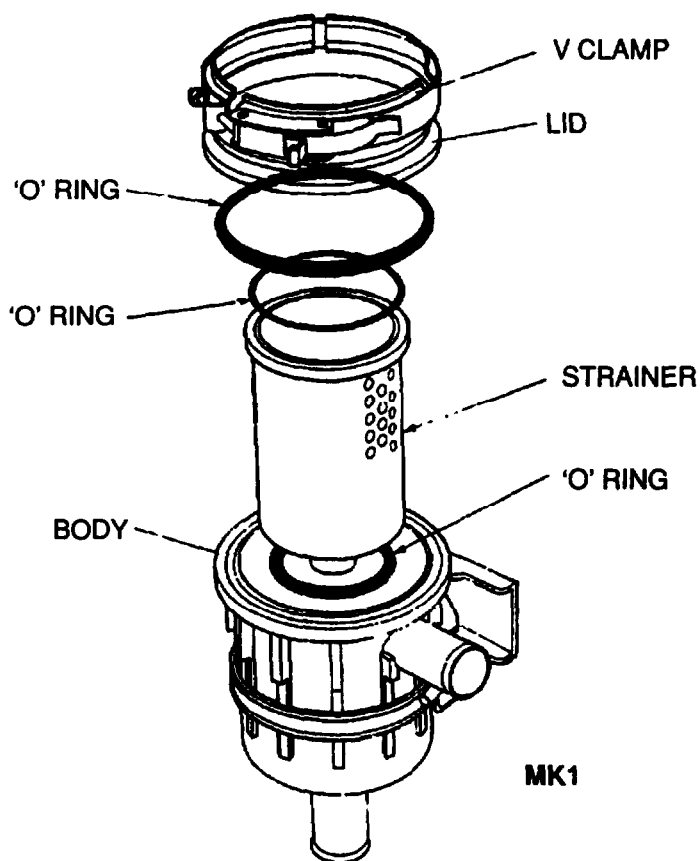

Section IV. TROUBLESHOOTING (Continued)

MALFUNCTION
TEST OR INSPECTION
CORRECTIVE ACTION

7. ENGINE OVERHEATS (ENGINE AUDIBLE ALARM ACTIVATES) - Continued.

- Step 1. Stop engine and turn engine circuit switch OFF.
- Step 2. Release retaining clips. Remove rim and lid.
 - a. Check condition of edging strip. Replace if damaged or worn.

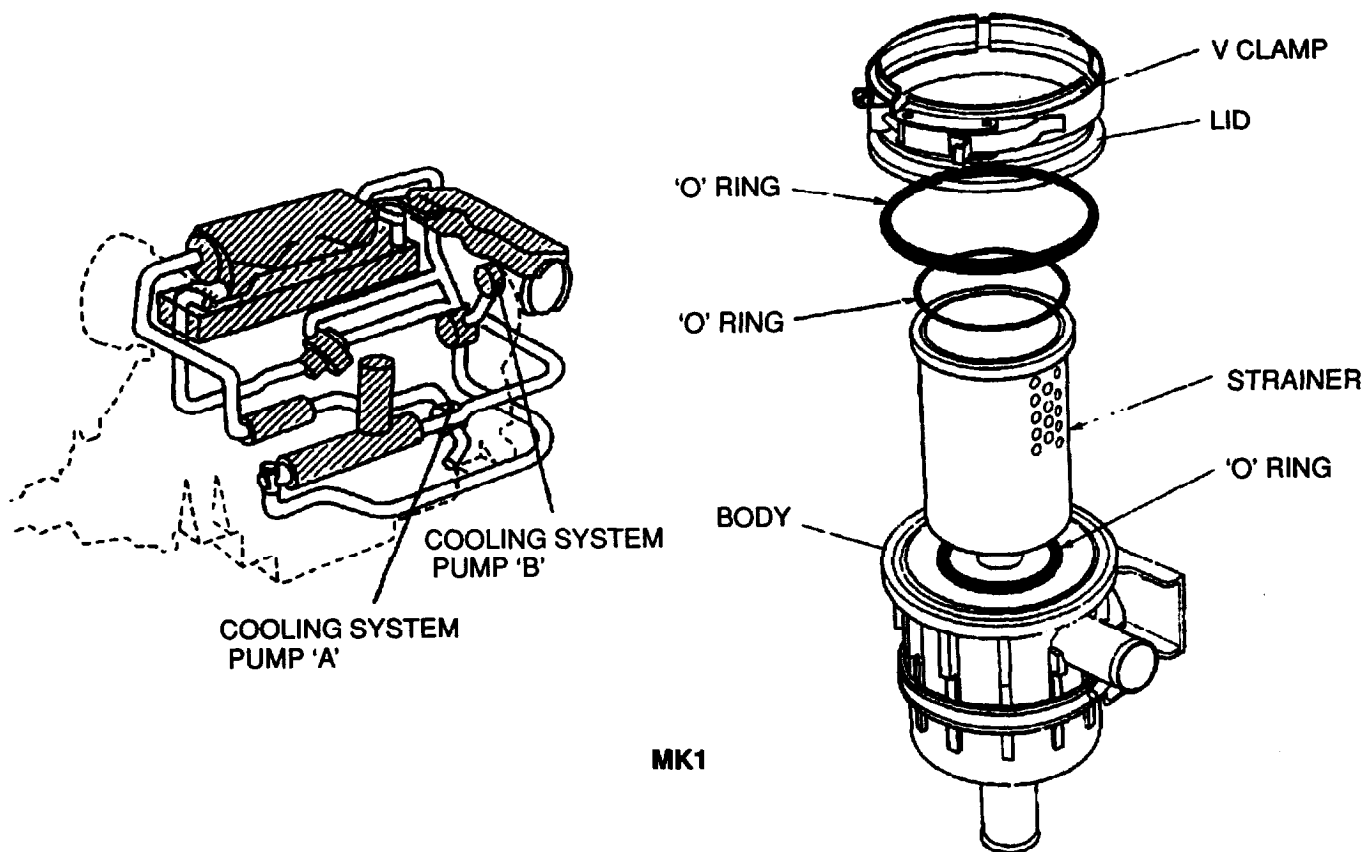

Section IV. TROUBLESHOOTING (Continued)

MALFUNCTION

TEST OR INSPECTION

CORRECTIVE ACTION

7. ENGINE OVERHEATS (ENGINE AUDIBLE ALARM ACTIVATES) - Continued.

- Step 3. Check water intake.
- a. Clean strainer and housing.
 - b. Replace strainer (refer to paragraph 3-66).
- Step 4. Inspect cooling system pump 'A' impeller, cam and end plate (refer to paragraph 3-80).
- a. Replace defective impeller.
 - b. Replace defective cam.
 - c. Replace end plate.
 - d. Replace cooling system pump 'A' (refer to paragraph 3-61).

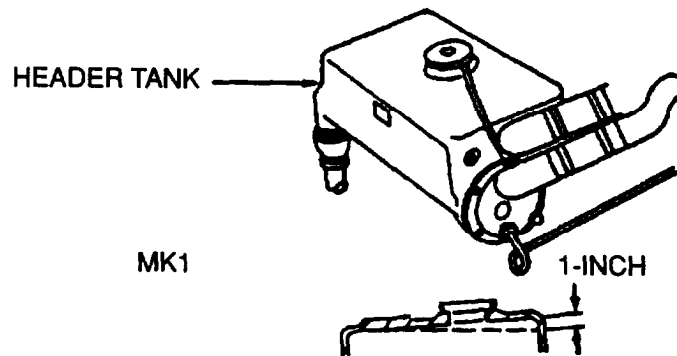

- Step 5. Check coolant level in header tank.
- a. Fill to 1" below neck.
- Step 6. Check for leaks in fresh water system.
- a. Tighten hose clamps.
 - b. Replace defective hoses (refer to paragraph 3-67).
 - c. Repair header tank (refer to paragraph 3-71).
 - d. Replace header tank (refer to paragraph 3-72).
- Step 7. Check raw water hoses and fittings (refer to paragraph 3-67).
- a. Tighten hose clamps.
 - b. Replace defective hoses and fittings (refer to paragraph 3-67).
- Step 8. Check V-belt for looseness, breaks, or fraying.
- a. Adjust to correct tension (refer to paragraph 3-119).
 - b. Replace V-belt (refer to paragraph 3-119).

Section IV. TROUBLESHOOTING (Continued)

MALFUNCTION

TEST OR INSPECTION

CORRECTIVE ACTION

7. ENGINE OVERHEATS (ENGINE AUDIBLE ALARM ACTIVATES) - Continued.

Step 9. Check thermostat (refer to paragraph 3-73).

- a. Replace thermostat (refer to paragraph 3-73). Do not operate engine without thermostat installed.

Step 10. Check cooling system pump for leaks.

- a. Replace defective pump (refer to paragraph 3-70).

Step 11. Check intercooler for loose connections or leaks.

- a. Tighten loose raw water hose dampers.

Step 12. Check water temperature sending unit.

- a. Replace defective water temperature sending unit (refer to paragraph 3-101).

Step 13. Check for clogged remote cooler (MK1).

- a. Clean tube stack (refer to paragraph 3-78).

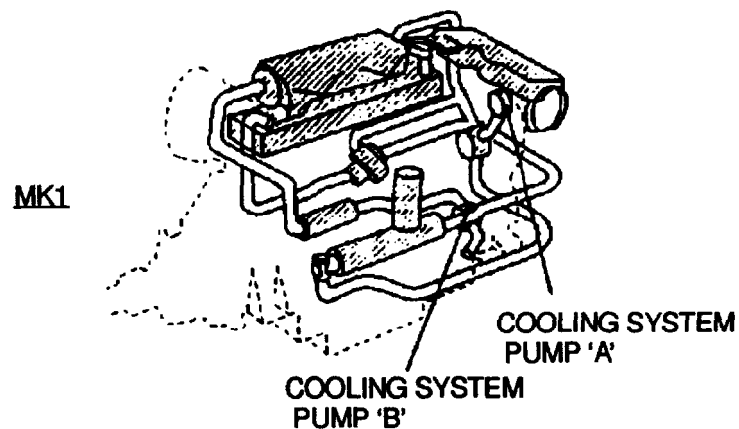

Section IV. TROUBLESHOOTING (Continued)

MALFUNCTION

TEST OR INSPECTION

CORRECTIVE ACTION

7. ENGINE OVERHEATS (ENGINE AUDIBLE ALARM ACTIVATES) - Continued.

b. MK2.

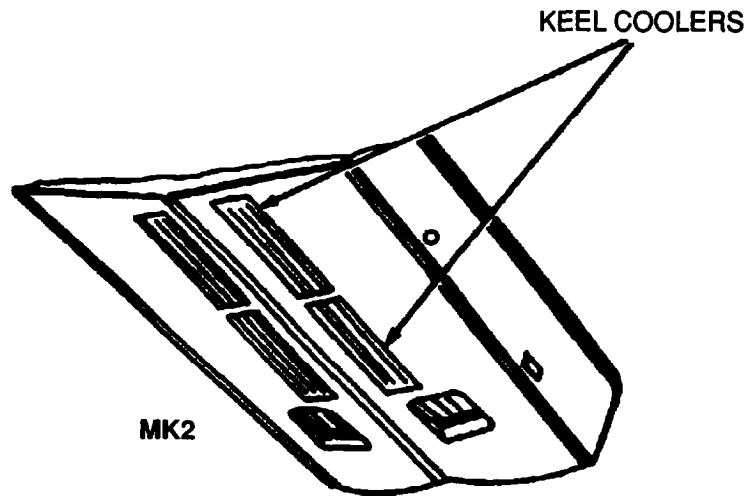

Step 1. Stop engine and turn engine circuit switch OFF.

Step 2. Check keel cooler for marine growth and other foreign matter. Also check for leaks, cracked nickel plating, or any sign of corrosion.

a. Clean keel coolers with wire brush.

b. Replace keel coolers (refer to paragraph 3-77).

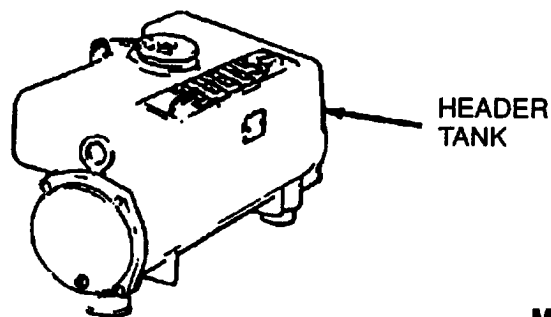

Section IV. TROUBLESHOOTING (Continued)

MALFUNCTION

TEST OR INSPECTION

CORRECTIVE ACTION

7. ENGINE OVERHEATS (ENGINE AUDIBLE ALARM ACTIVATES) - Continued.

- Step 3. Check coolant level in header tank.
- a. Fill to 1" below neck.
- Step 4. Check for leaks in secondary cooling system.
- a. Tighten hose clamps.
 - b. Replace defective hoses (refer to paragraph 3-67).
 - c. Replace header tank (refer to paragraph 3-72).
- Step 5. Inspect secondary water pump impeller, cam, and end plate (refer to paragraph 3-79).
- a. Replace defective impeller (refer to paragraph 3-80).
 - b. Replace defective cam (refer to paragraph 3-80).
 - c. Replace end plate (refer to paragraph 3-80).
 - d. Replace secondary water pump (refer to paragraph 3-81).
- Step 6. Test water temperature sending unit (refer to paragraph 3-153).
- a. Replace defective water temperature sending unit (refer to paragraph 3-101).
- Step 7. Check V-belt for looseness, breaks, or fraying.
- a. Adjust to correct tension (refer to paragraph 3-119).
 - b. Replace V-belt (refer to paragraph 3-119).
- Step 8. Check primary cooling system for leaks.
- a. Tighten hose clamps (refer to paragraph 3-67).
 - b. Replace defective hoses (refer to paragraph 3-67).
- Step 9. Check primary water pump for leaks.
- a. Replace defective primary water pump (refer to paragraph 3-70).

CAUTION

Do not beach boat on rock shores. Damage to keel and keel cooler may result.

- b. Replace thermostat (refer to paragraph 3-73).

Section IV. TROUBLESHOOTING (Continued)

MALFUNCTION

TEST OR INSPECTION

CORRECTIVE ACTION

8. ENGINE OIL PRESSURE LOW (ENGINE AUDIBLE ALARM COMES ON) (LOW GAGE READING).

- Step 1. Turn engine alarm mute switch OFF.
- Step 2. Check engine oil level (refer to paragraph 3-76).
 - a. Fill to proper level (refer to paragraph 3-76).
- Step 3. Check oil filter element.
 - a. Tighten if leaking.
 - b. Replace oil filter element (refer to paragraph 3-76).
- Step 4. Check oil lines and fittings.
 - a. Tighten connections.
 - b. Replace defective lines and fittings.
- Step 5. Check water in header tank for oil film as evidence of oil cooler leak (refer to paragraph 3-72).
 - a. Repair oil cooler (refer to paragraph 3-75).
 - b. Replace oil cooler (refer to paragraph 3-74).
- Step 6. Check oil pressure sending unit.
 - a. Replace defective sending unit (refer to paragraph 3-101).

9. SUDDEN LOSS OF OIL PRESSURE.

- Step 1. Check engine oil level.
 - a. Fill to proper level (refer to paragraph 3-134).
- Step 2. Check for oil leaks (engine running).
 - a. Repair leaks.
 - b. Contact Direct Support Maintenance.
- Step 3. Check oil pressure sending unit.
 - a. Replace defective sending unit (refer to paragraph 3-101).

Section IV. TROUBLESHOOTING (Continued)

MALFUNCTION

TEST OR INSPECTION

CORRECTIVE ACTION

10. ENGINE CRANKS SLOWLY (COLD START ATTEMPT).

- Step 1. Check engine transmission control setting (refer to paragraph 3-37).
- a. Set transmission control in neutral (refer to paragraph 3-37).

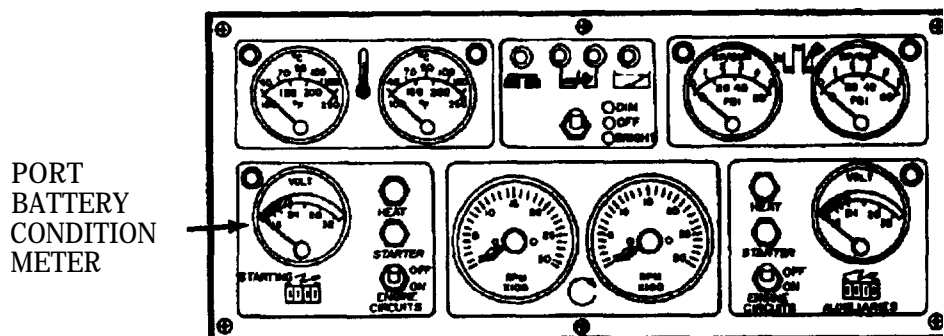

- Step 2. Check starting battery charge using port battery condition meter.
- a. If reading is 24.5 to 25.5 volts connect emergency link and start engine.

11. TRANSMISSION SHIFTS HARD.

- Step 1. Check transmission oil level.
- a. Fill to proper level (refer to paragraph 3-135).
- Step 2. Check transmission lines and fittings.
- a. Tighten loose connections and fittings.
 - b. Replace defective lines and fittings (refer to paragraph 3-136).
- Step 3. Check oil strainer assembly (refer to paragraph 3-135).
- a. Service oil strainer assembly (refer to paragraph 3-135).

NOTE

- If metal filings or chips are found report to Direct Support Maintenance.
- b. Replace oil strainer assembly (refer to paragraph 3-135).

12. TRANSMISSION SLIPS OUT OF GEAR.

- Step 1. Check transmission lines and fittings.
- a. Tighten loose connections and fittings.
 - b. Replace defective lines and fittings (refer to paragraph 3-136).
- Step 2. Check transmission control linkage adjustment.
- a. Adjust transmission control linkage.

Section IV. TROUBLESHOOTING (Continued)

MALFUNCTION

TEST OR INSPECTION

CORRECTIVE ACTION

13. STEERING SYSTEM OUT OF ALIGNMENT.

- Step 1. Check steering cable.
 - a. Replace steering cable (refer to paragraph 3-42).
- Step 2. Check tie rod.
 - a. Adjust tie rod (refer to paragraph 3-45).
 - b. Replace tie rod (refer to paragraph 3-46).
- Step 3. Check hydrojet unit steering assembly (refer to paragraph 3-45).
 - a. Adjust steering assembly (refer to paragraph 3-45).
- Step 4. Check steering wheel assembly.
 - a. Repair steering wheel assembly (refer to paragraph 3-43).
 - b. Replace defective steering wheel assembly (refer to paragraph 3-44).

14. ENGINE RUNS BUT BOAT FAILS TO MOVE.

- Step 1. Check transmission control setting.
 - a. Adjust transmission control cables and linkages (refer to paragraph 3-37).
 - b. Replace defective transmission control cables and linkages (refer to paragraph 3-39).
- Step 2. Check transmission oil level.
 - a. Fill to proper level.
- Step 3. Inspect drive shaft couplings (refer to paragraph 3-141).
 - a. Replace defective drive shaft coupling (refer to paragraph 3-141).

15. ELECTRICAL SYSTEMS INOPERATIVE.

- Step 1. Check position of master battery switch.
 - a. Set master battery switch "ON".

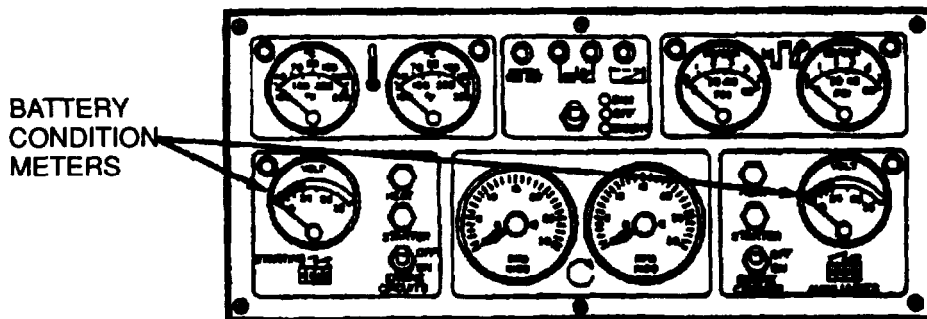

- Step 2. Check battery condition using battery condition meters.
 - a. If reading below 24 vdc go to Step 4.

Section IV. TROUBLESHOOTING (Continued)

MALFUNCTION

TEST OR INSPECTION

CORRECTIVE ACTION

15. ELECTRICAL SYSTEMS INOPERATIVE - Continued.

Step 3. Check battery connections and cables (refer to paragraph 3-90).

a. Clean and tighten connections (refer to paragraph 3-90).

b. Replace defective cables (refer to paragraph 3-90).

Step 4. Test batteries (refer to paragraph 3-33).

a. Replace defective battery (refer to paragraph 3-39).

Step 5. Check master battery switch.

a. Replace defective master battery switch (refer to paragraph 3-100).

16. ONE OR BOTH WARNING LIGHTS DO NOT COME (Master Switch ON).

Step 1. Check engine circuit switch.

a. Turn engine circuit switch ON.

Step 2. Perform engine circuit fuse test (Refer to paragraph 3-117).

a. Replace defective fuse.

Step 3. Check batteries.

a. Replace defective batteries (Refer to paragraph 3-99).

Step 4. Check battery cables.

a. Replace or repair damaged cables. (Refer to paragraph 3-90).

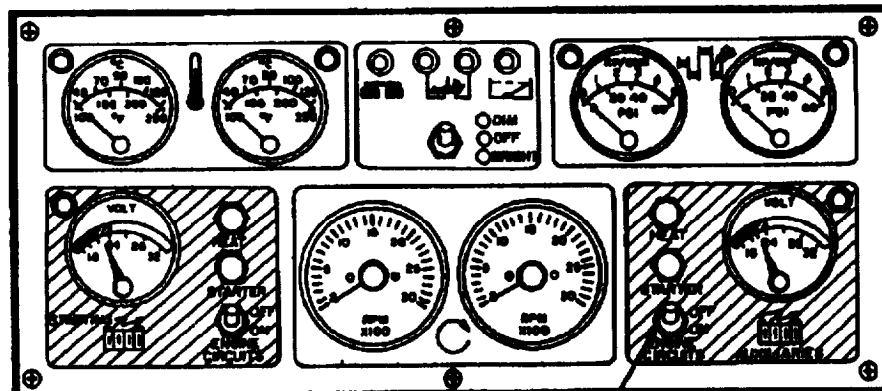

ENGINE CIRCUIT SWITCH

Section IV. TROUBLESHOOTING (Continued)

MALFUNCTION

TEST OR INSPECTION

CORRECTIVE ACTION

17. INDIVIDUAL LIGHTS INOPERATIVE.

Step 1. Inspect individual lamps.

- a. Replace defective lamps (refer to paragraph 3-93 or 3-94 for anchor lamp or paragraph 3-95 or 3-96 for towing, steaming or navigational lamps).

Step 2. Test light switches.

- a. Replace defective switch panel unit 1 (refer to paragraph 3-50).

18. INSTRUMENT PANEL GAGE INOPERATIVE.

(Water temperature, oil pressure)

Step 1. Test individual sending unit (refer to paragraph 3-153).

- a. Replace defective sending unit (refer to paragraph 3-101).

Step 2. Inspect individual gages (refer to paragraph 3-47).

- a. Replace individual gage (refer to paragraph 3-47).

19. HORN ONLY FAILS TO OPERATE.

Step 1. Test for 24 vdc at horn connections.

- a. Replace defective horn (refer to paragraph 3-55).
- b. Replace defective switch panel unit 2 (refer to paragraph 3-51).

20. WINDSHIELD WIPERS OPERATE BUT DON'T CLEAN WINDSHIELD.

Step 1. Inspect windshield wiper blades.

- a. Replace defective windshield wiper blades (refer to paragraph 3-11).

Section IV. TROUBLESHOOTING (Continued)

MALFUNCTION

TEST OR INSPECTION

CORRECTIVE ACTION

21. WINDSHIELD WIPERS ONLY FAIL TO OPERATE.

Step 1. Visually inspect wiper motor for normal operation.

- a. If wiper motor operating go to Step 2.
- b. If not operating go to Step 3.

Step 2. Inspect windshield wiper drive unit.

- a. Repair windshield wiper drive unit (refer to paragraph 3-13).
- b. Replace windshield wiper drive unit (refer to paragraph 3-14).

Step 3. Check for presence of power at cab to console connector.

- a. Replace wiper switch.
- b. If power present replace connector to wiper wiring.

22. SCUPPERS DON'T DRAIN WATER FROM BOAT

Step 1. Inspect scupper drains (refer to paragraphs 3-29 and 3-30).

- a. Clean scupper drains (refer to paragraphs 3-29 and 3-30).
- b. Replace defective scupper drains.

23. ELECTRIC BILGE PUMP DOES NOT DISCHARGE WATER (FORWARD OR AFT) (MK1).

Step 1. Check intake screen for blockage.

- a. Clean intake screen.

Step 2. Inspect electrical connections and cables.

- a. Tighten loose connections.
- b. Replace defective cables and connections (refer to paragraph 3-143).

Step 3. Test switch (refer to paragraph 3-48).

- a. Replace defective switch (refer to paragraph 3-47).

Step 4. Inspect pump assembly.

- a. Repair pump assembly (refer to paragraph 3-145).
- b. Replace defective pump assembly (refer to paragraph 3-143).

24. ELECTRIC BILGE PUMP DOES NOT DISCHARGE WATER (FORWARD OR AFT) (MK2).

Step 1. Check intake screen for blockage.

- a. Clean intake screen.

Step 2. Inspect electrical connections, cables, and switch panel unit 2.

- a. Tighten loose connections.
- b. Replace defective switch panel unit 2 (refer to paragraph 3-51).

Section IV. TROUBLESHOOTING (Continued)

MALFUNCTION

TEST OR INSPECTION

CORRECTIVE ACTION

24. **ELECTRIC BILGE PUMP DOES NOT DISCHARGE WATER (FORWARD OR AFT) (MK2) - Continued.**

- Step 3. Inspect pump assembly.
- a. Repair pump assembly (refer to paragraph 3-145).
 - b. Replace defective pump assembly:
 - For MK2 aft pump, refer to paragraph 3-143.
 - For MK2 forward pump, refer to paragraph 3-144.

25. **HAND BILGE PUMP DOES NOT DISCHARGE WATER (MK1 only).**

- Step 1. Check hand bilge pump assembly.
- a. Repair hand bilge pump assembly (refer to paragraph 3-147).
 - b. Replace defective hand bilge pump assembly (refer to paragraph 3-146).

26. **BOAT VIBRATION FELT WHILE UNDER WAY.**

NOTE

Boat must be out of water on cradle or on hardstand to inspect hydrojet unit anode.

- Step 1. Inspect hydrojet unit anode.
- a. Replace defective anode (refer to paragraph 3-139).
- Step 2. Check transmission oil level.
- a. Fill to proper level (refer to LO 5-1940-277-12-1.)
- Step 3. Inspect drive shaft couplings (refer to paragraph 3-141).
- a. Replace defective drive shaft coupling (refer to paragraph 3-141).

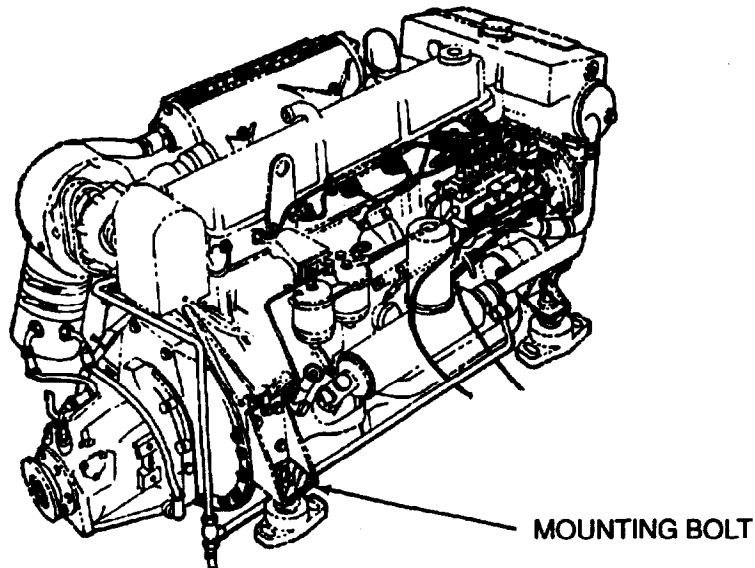

Section IV. TROUBLESHOOTING (Continued)

MALFUNCTION

TEST OR INSPECTION

CORRECTIVE ACTION

- 26. BOAT VIBRATION FELT WHILE UNDER WAY - Continued.**
Step 4. Check engine mounting bolt torques.
a. Torque to 30 - 35 ft-lbs.
- 27. ENGINE FAILS TO STOP WHEN SHUT OFF.**
Step 1. Inspect engine stop cable.
a. Replace defective engine stop cable (refer to paragraph 3-41).
- 28. ENGINE STARTS BUT FAILS TO KEEP RUNNING.**
Step 1. Inspect operation of fuel lift pump assembly.
a. Replace fuel lift pump assembly (refer to paragraph 3-63).
- 29. WATER TEMPERATURE GAGE NOT REGISTERING ALTHOUGH GAGE IS OPERATIVE.**
Step 1. Check operation of water temperature sending unit.
a. Replace water temperature sending unit (refer to paragraph 3-101).
- 30. OIL PRESSURE GAGE NOT REGISTERING ALTHOUGH GAGE IS OPERATIVE.**
Step 1. Check operation of oil temperature sending unit.
a. Replace oil temperature sending unit (refer to paragraph 3-101).
- 31. LAMPS NOT OPERATING.**
Step 1. Check lamp sockets for corrosion.
a. If corrosion present remove corrosion.
b. If corrosion not present go to Step 2.
Step 2. Check spring action of lamp socket terminals.
a. If terminals defective replace lamp sockets (refer to paragraphs 3-95 and 3-96).
- 32. NO POWER ON BOAT ALTHOUGH BATTERIES ARE GOOD.**
Step 1. Check master battery switch.
a. Replace defective master switch (refer to paragraph 3-100).

Section V. MAINTENANCE PROCEDURES

- 2-6. GENERAL.** This section covers general information for disassembly, cleaning, inspection, repair and assembly for component parts of bridge erection boat. Specific instructions for individual component maintenance are covered in the appropriate sections.
- 2-7. DISASSEMBLY.** It is recommended that groups of related parts be kept together, preferably in a tray, to prevent their being lost. For those components which have too many or too large parts to use trays it is recommended that the parts be tagged with their names as they are disassembled. This will make it easier to identify parts when assembling the components. Precision matched or mated parts will be marked to ensure reassembly in the proper position and place.
- 2-8. CLEANING.** All parts except bearings are to be cleaned as specified in TM 9-247. Bearings should be cleaned as specified in TM 9-214.
- 2-9. INSPECTION.**
- a. General. The importance of carefully inspecting disassembled parts cannot be stressed enough. Reassembly of substandard or defective parts can result in needless troubleshooting, disassembly and inspection. Inspection procedures must be performed by experienced personnel using proper tools and equipment. All measuring and testing equipment must be checked periodically and when required accurately calibrated in accordance with current directives. The compilation of complete and accurate inspection records as specified in DA Pam 738-750 is a necessary part of all inspection actions.
 - b. Metallic Parts. The following procedures should be followed when inspecting metallic parts.
 - (1) All parts should be inspected for cracks.
 - (2) Inspect gear teeth retaining ring grooves and mating surfaces for burrs.
 - (3) Mating and polished surfaces should be inspected for nicks, scratches and rust. Any nick, scratch, or rust is cause for rejection.
 - (4) Sheet metal parts should be inspected for bends, cracks, tears, broken corners or defective welds.
 - c. Non-metallic Parts. Non-metallic parts such as seals and gaskets are not subject to inspection. They will be disposed of upon removal and replaced by new items during assembly.
- 2-10. REPAIR.**
- a. Hull parts that are cracked may be repaired by welding if it does not distort or impair the strength of the part. Welding procedures will be accomplished as specified in TM 9-237.
 - b. A fine file or hone may be used to remove small burrs from gear teeth, retaining ring grooves and mating surfaces. The burrs must be very minor and if on gears only on the engaging edge of the teeth.
 - c. Damaged painted surfaces should be repainted as soon as possible to prevent corrosion.
- 2-11. ASSEMBLY.** Step-by-step procedures for assembly of bridge boat components are provided in Chapter 3. In addition the following practices should be observed.
- a. The housing contact surface of oil seals should be coated with a non-hardening sealer to prevent leaks. The lips should be coated with grease (GAA).
 - b. All pressing operations should be accomplished using a suitable press and adapters unless otherwise specified.
 - c. Metallic parts should be lubricated with the lubricant utilized in the component during operation.
 - d. Critical torque values are specified in the assembly procedures.
 - e. Silicone sealant is used on gaskets and mating surfaces in the engine assembly.

2-12. DETAILED PROCEDURE GENERAL INFORMATION.

- a. Resources required are not listed unless they apply to the procedure.
- b. Personnel required are listed only if the task requires more than one. If PERSONNEL are not listed it means that one person can do the task.
- c. The normal standard equipment condition to start a maintenance task is power (MASTER SWITCH) OFF. EQUIPMENT CONDITION is not listed unless some other condition is required besides the power (MASTER SWITCH) being OFF.
- d. The MK1 and MK2 engines WILL NOT be operated out of water for more than 20 minutes at idle speed. Any maintenance task step that requires engine operation MUST BE performed with the boat in water or by following the procedures on paragraph 3-155 for MK1 or paragraph 3-156 for MK2, out of water engine operation.
- e. Standard maintenance procedure requires that upon completion of a maintenance action a component function and performance check be conducted to assure no leakage or malfunction exists. If leakage or malfunction is found repeat the maintenance procedure to correct problem.
- f. Standard maintenance procedure requires that an operational check be performed after completion of repairs if possible. This step is not called out as part of the procedure. The operator's manual TM 5-1940-277-10 0 should be consulted for information on boat operation.
- g. Bleed fuel system anytime work has been performed on fuel system components (paragraph 3-64).

CHAPTER 3

COMPONENT MAINTENANCE INSTRUCTIONS (UNIT LEVEL)

Section I. GENERAL

This chapter contains maintenance information for the bridge erection boat, the major subassemblies, subsystems, hull and associated items. Tasks discussed in this manual are those to be performed by Unit Maintenance personnel as listed in the Maintenance Allocation Chart.

- 3-1. ENGINES.** The engines are installed side by side in the midsection of the boat. All references to rotation of the engine or location of components are based on viewing the engine from the rear (transmission end). Each engine is an in-line six-cylinder, four-cycle, turbocharged diesel.

CAUTION

The MK1 and MK2 engines will not be operated out of water nor operated in the water with the water jet disengaged for more than 20 minutes at idle speed. Ensure that the engine water temperature does not rise above 194°F. Serious engine damage could result if this is not observed.

For out of water operation during unit or higher maintenance actions, refer to paragraph 3-155 for the MK1 and to paragraph 3-156 for the MK2.

3-2. COOLING SYSTEM

- a. The MK1 uses two closed fresh water systems. Raw water is also drawn from the hydrojet unit to pass through a remote heat exchanger unit which cools the fresh water flowing through the remote unit's coil. The exhaust system expels exhaust gases and raw water via port and starboard wet exhaust outlets.

CAUTION

The MK1 and MK2 engines will not be operated out of water nor operated in the water with the water jet disengaged for more than 20 minutes at idle speed. Ensure that the engines water temperature does not rise above 194°F. Serious engine damage could result if this is not observed.

For out of water operation during unit or higher maintenance actions, refer to paragraphs 3-155 for the MK1 and to paragraph 3-156 for MK2.

- b. The MK2 engine cooling system consists of two separate systems, the primary cooling system and the secondary cooling system, which share the same reservoir. Both cooling systems circulate coolant through keel coolers where heat is exchanged from the coolant to the raw water beneath the hull.

CAUTION

The MK2 engines will not be operated out of water for more than 20 minutes at Idle speed. Serious engine damage could result.

For out of water operation during unit or higher maintenance actions, refer to paragraph 3-156.

- 3-3. FUEL SYSTEM.** The fuel system consists of a tank, valves, fuel water separators, fuel pumps, fuel filters, injection pump, injectors and the piping and hoses to connect the components. A detailed description of the fuel system is contained in TM 5-1940-277-10.



Maintenance procedures for the fuel system must be performed in a well-ventilated area. Do not allow sparks, flame, or smoking in the vicinity. Serious Injury to personnel may result.

- 3-4. ELECTRICAL SYSTEM.** The electrical system is a 24-volt direct current wired return type. There are a total of four 12-volt batteries in the system. Two batteries are connected in series to provide 24 volts. The port set of batteries provides power for starting engines and port engine instruments. The starboard set of batteries provides power for the auxiliaries and the starboard engine instruments. Each set of batteries is normally charged by alternator output for its respective engine. Should one alternator fail an automatic system allows charging of both sets of batteries by one alternator. To assist in engine starting under difficult conditions, a solenoid switch operated from the switch panel can be used to line both sets of batteries in parallel. An inter-vehicle starting socket is connected to port batteries to enable an additional external power source to be used, or to enable assistance to be given to other boats. A system wiring diagram is shown in the foldout in the back of the manual.



Before performing any repair on the electrical system, place master switch OFF and disconnect battery negative cables.

- 3-5. ENGINE LUBRICATION.** Due to lack of space the oil must be pumped from the engine sump. There will always be some oil left in the sump. When filling at an oil change it is advisable to start checking oil level after putting in about 15 quarts.
- 3-6. OTHER MAJOR ITEMS.** The fire extinguishers are suitable for electrical and flammable liquid fires. There is one extinguisher fixed in place on each engine hatch cover and one hand-portable extinguisher mounted in the operator's cockpit area. There are two electric bilge pumps. One is located in the aft of the engine compartment and the second in the stem of the boat.

Section II. MAINTENANCE PROCEDURES

MAINTENANCE PROCEDURE INSTRUCTIONS INDEX

	Procedure	Paragraph
MAST		
	Master Repair	3-7
	Mast Replacement	3-8
CAB		
	Cab Assembly Repair	3-9
	Cab Assembly Replacement	3-10
	Windshield Wiper Blade Replacement	3-11
	Windshield Wiper Motor Replacement	3-12
	Windshield Wiper Drive Unit Repair	3-13
	Windshield Wiper Drive Unit Replacement	3-14
TOWING ATTACHMENTS AND ACCESSORY ITEMS		
	Capstan Assembly Servicing (MK1)	3-15
	Capstan Assembly Replacement (MK1)	3-16
	Capstan Assembly Servicing (MK2 and Retrofitted MK1)	3-17
	Capstan Assembly Replacement (MK2 and Retrofitted MK1)	3-18
	Tow Hook Assembly Replacement (MK2 and Retrofitted MK1)	3-19
	Tow Hook Assembly Repair (Spring and Lanyard Replacement - MK2 and Retrofitted MK1)	3-20
	Pushknees Repair (MK1)	3-21
	Pushknees Replacement (MK1)	3-22
	Pushknees Repair (MK2)	3-23
HATCHES, HINGES, AND SUPPORT BRACES		
	Battery Hatch Cover, Hinges, and Support Brace Replacement	3-24
	Engine Hatch Cover, Hinges, and Support Brace Replacement	3-25
	Hydrojet Hatch Cover, Hinges, and Support Brace Replacement	3-26
	Aft Cockpit Replacement	3-27
	Steering Unit Hatch Cover and Hinges Replacement	3-28
SCUPPER DRAINS		
	Scupper Drain (Forward Cockpit) Servicing and Replacement	3-29
	Scupper Drain (Aft Cockpit) Servicing and Replacement	3-30
CONTROLS		
	Scoop Control Head Assembly Repair	3-31
	Scoop Control Head Assembly Replacement	3-32
	Engine or Transmission Control Head Assembly Repair	3-33
	Engine or Transmission Control Head Assembly Replacement	3-34
	Linkage Scoop Control Assembly Adjustment	3-35
	Scoop Control Cable Replacement (Port and Starboard)	3-38
	Control Cable and Linkage Adjustment (Transmission and Engine)	3-37
	Transmission Cable Replacement	3-38
	Engine Throttle Cable Replacement	3-39
	Engine Stop Control Handle Replacement	3-40
	Engine Stop Control Cable Replacement	3-41
	Steering Cable Replacement	3-42
	Steering Wheel Assembly Repair	3-43
	Steering Wheel Assembly Replacement	3-44
	Steering Tie Rod Adjustment	3-45
	Steering Tie Rod Inspection and Replacement	3-46

INSTRUMENT PANEL

Gage Lamp Replacement, Gage Replacement, Warning Lamp Replacement, Gage Lamp Dinner Switch Replacement, Switch Replacement	3-47
Heat/Start And Toggle Switch Test	3-48
Engine Alarm Mute Switch Replacement	3-49
Switch Panel Unit #1 Replacement Instructions	3-50
Switch Panel Unit #12 Replacement Instructions	3-51
Junction Box Unit 1 Replacement Instructions	3-52
Junction Box Unit 2 Replacement Instructions	3-53
Switch Panel Unit #1 To Junction Box Unit 1 Wiring Harnesses Test	3-54
Horn Replacement	3-55
Engine Audible Alarm Replacement	3-56

FUEL SYSTEM

Fuel Tubing Replacement	3-57
Engine Fuel Shutoff Valve and Diaphragm Replacement	3-58
Fuel Master Shutoff Valve Replacement	3-59
Fuel Water Separator Servicing	3-60
Fuel Water Separator Replacement	3-61
Fuel Filters Replacement	3-62
Fuel Lift Pump Assembly Replacement	3-63
Fuel System Bleeding	3-64

EXHAUST SYSTEM

Exhaust Flexible Bellows Replacement Instructions (MK1 - Port And Starboard)	3-65
Exhaust Flexible Bellows Replacement (MK2 - Port and Starboard)	3-66

COOLING SYSTEM

Piping, Hoses, and Fittings Replacement	3-67
Drain and Refill Fresh Water Cooling System (MK1)	3-68
Drain and Refill Primary and Secondary Cooling System (MK2)	3-69
Fresh (MK1) or Primary (MK2) Water Pump Replacement (Port or Starboard)	3-70
Header Tank/Heat Exchanger Repair Instructions (MK1)	3-71
Header Tank Replacement Instructions	3-72
Engine Thermostat Replacement (Port or Starboard)	3-73
Engine Oil Cooler Replacement (Port or Starboard)	3-74
Engine Oil Cooler Repair	3-75
Engine Oil Filter Element Replacement	3-76
Keel Cooler (Front and Rear) Replacement (MK2)	3-77
Remote Cooler Inspection and Replacement Instructions (MK1 - Port and Starboard)	3-78
Cooling System (MK1) or Secondary (MK2) Water Pump Inspection	3-79
Cooling System (MK1) or Secondary (MK2) Wafer Pump Repair	3-80
Cooling System (MK1) or Secondary (MK2) Water Pump Replacement	3-81
Intercooler Repair (Port and Starboard)	3-82
Intercooler Replacement (Port and Starboard)	3-83
Transmission Oil Cooler Inspection and Repair	3-84
Transmission Oil Cooler Replacement	3-85

Intake Strainer (MK1) Replacement Instructions.	3-86
ELECTRICAL SYSTEM	
Slave Starting	3-87
Battery Testing	3-88
Battery Replacement	3-89
Battery Cables Replacement	3-90
Alternator and Voltage Regulator Test	3-91
Alternator Replacement	3-92
Anchor Light Assembly Replacement (MK1)	3-93
Anchor Light Assembly Replacement (MK2)	3-94
Towing, Steaming, and Navigation Light Assembly Replacement (MK1)	3-95
Towing, Steaming, and Navigation Light Assembly Replacement (MK2)	3-98
Searchlight Replacement	3-97
inspection Light Replacement	3-98
Map Light Replacement (MK1 only)	3-99
Master Switch Replacement	3-100
Oil and Water Sending Units Replacement	3-101
Fuel Level Sending Unit Replacement	3-102
Tachometer Sending Unit Assembly Replacement	3-103
Tachometer Sending Unit Assembly inspection and Repair	3-104
Electrical Leads, Cables, and Connectors Inspection, Repair and Replacement	3-105
Emergency Link Solenoid Test and Replacement	3-106
Thermostat Unit Replacement	3-107
Blocking Diode Test	3-108
Blocking Diode Replacement	3-109
Control Box Cover Removal and Installation	3-110
Control Box Test	3-111
Engine Hour Meter Test	3-112
Engine Hour Meter Replacement	3-113
Surge Protection Unit Test	3-114
Solenoid Test	3-115
Fast Fuse Test:	3-116
Engine Circuit Fuse Test	3-117
Fast Fuse Replacement	3-118
ENGINE	
Engine V-Belt Replacement	3-119
Starter Test	3-120
Starter Replacement (Port or Starboard)	3-121
Exhaust Manifold Replacement	3-122
Turbocharger Replacement	3-123
Injector Line and Fitting Replacement	3-124
Engine Valve Cover Removal and Installation	3-125
Rocker Arms, Shaft, and Push Rods Inspection and Replacement	3-128
Injector Replacement	3-127
Engine Valve Tappets Adjustment	3-128
Crankshaft Pulley Replacement	3-129
Flywheel and Starter Ring Gear Inspection	3-130
Sump Pump Replacement	3-131
Engine Breather Water Trap Assembly Replacement	3-132
Air Filter Silencer Servicing and Replacement	3-133
Engine Oil Replacement	3-134

TRANSMISSION

Transmission Oil Strainer Assembly Inspection, Servicing and Replacement	3-135
Transmission Oil Hoses and Fittings Replacement	3-136
Transmission Inspection	3-137

HYDROJET UNIT

Steering Assembly Brush Replacement	3-138
Hydrojet Tail Cone Anodes Replacement	3-139
Oil Reservoir Repair	3-140

DRIVE SHAFT ASSEMBLY

Drive Shaft Replacement	3-141
Drive Shaft Assembly Repair	3-142

BILGE PUMP

Electric Bilge Pumps Replacement	3-143
Forward Electric Bilge Pump Replacement (MK2)	3-144
Electric Bilge Pumps Assembly Repair	3-145
Hand Bilge Pump Assembly Replacement (MK1)	3-146
Hand Bilge Pump Assembly Repair (MK1)	3-147

FIRE EXTINGUISHER

Automatic Fire Extinguisher Replacement	3-148
Hand Fire Extinguisher Replacement	3-149

HULL

Keel Anodes Replacement	3-150
Fendering (Rubber Rub Rail) Replacement	3-151
Buoyancy Material Removal and Installation	3-152
Multimeter - Set-up and Use to Test Electrical System	3-153
Access Hatches Opening and Securing, Battery Hatch, Engine Hatch (Port and Starboard), Hydrojet Hatch (Port and Starboard), Control Console Access Hatch	3-154
Out of Water Engine Operation (MK1)	3-155
Out of Water Engine Operation (MK2)	3-156
Aft Cleat Replacement	3-157
Boat Hook Holder Replacement	3-156

3-7. MAST REPAIR INSTRUCTIONS

TOOLS: Two 3/4-inch Box Wrenches

PARTS/MATERIALS: Upper Mast Section

NOTE

Mast repair consists of replacing damaged upper and lower mast sections

REPLACE UPPER MAST SECTION:

REMOVE:

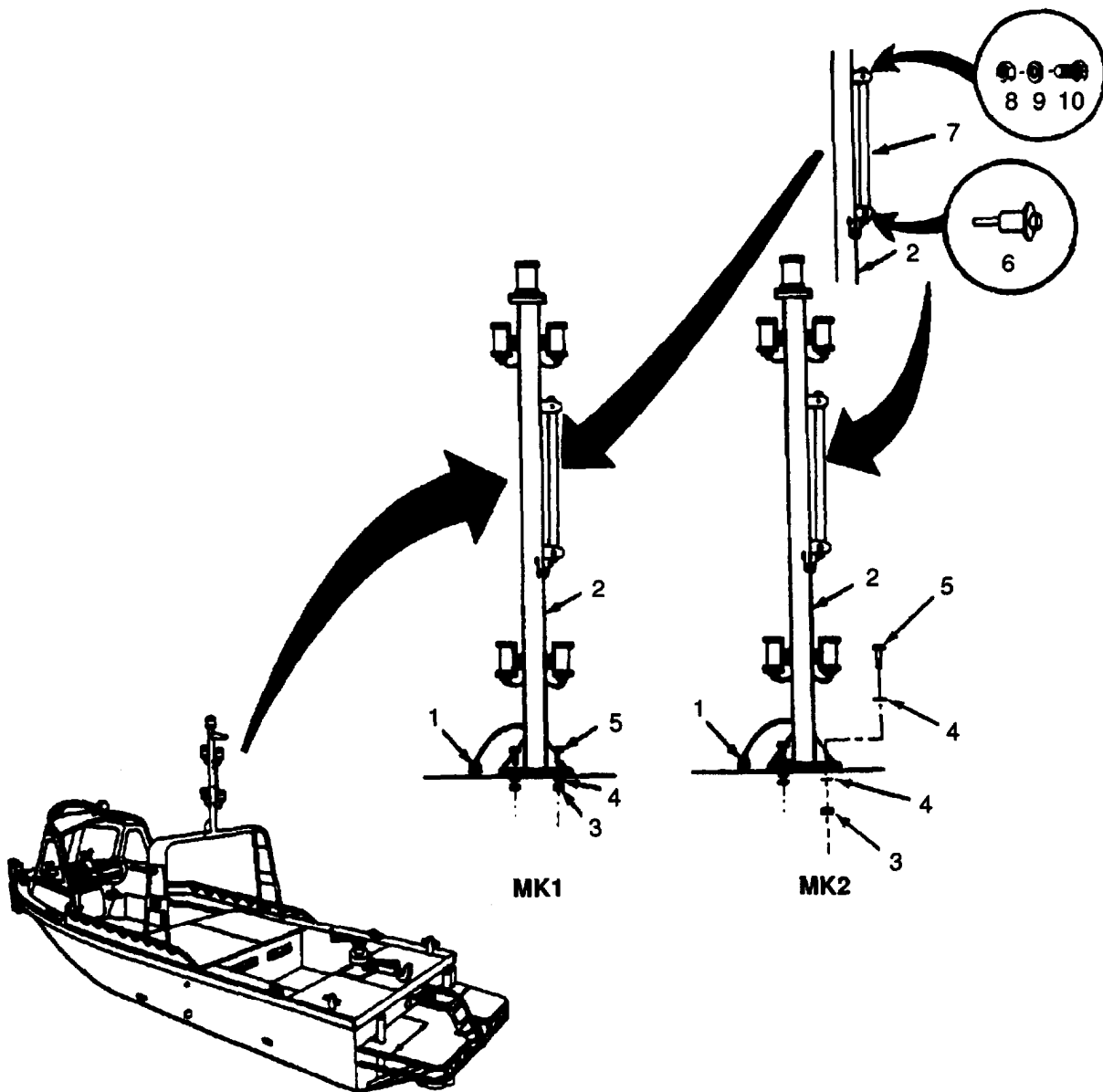

1. Disconnect electrical socket (1) at base of upper mast section (2).
2. Using two wrenches remove four nuts (3), washers (4) and bolts (5) securing upper mast section (2) to base. MK2 has eight washers (4).

INSTALL:

3. Replace with new upper mast section.
4. Depress release button on retaining pin (6) that is securing mast stay (7), and remove pin.
5. Using two 6 mm wrenches remove nut (8), flat washer (9), bolt (10) and remove mast stay (7).

3-8. MAST REPLACEMENT INSTRUCTIONS

TOOLS: Two 3/4-inch Box Wrenches

PARTS/MATERIALS: Mast Assembly

PERSONNEL REQUIRED: Two

REMOVE:



Position boat where the mast will not contact overhead electrical lines during removal. Contact during replacement could seriously injure personnel

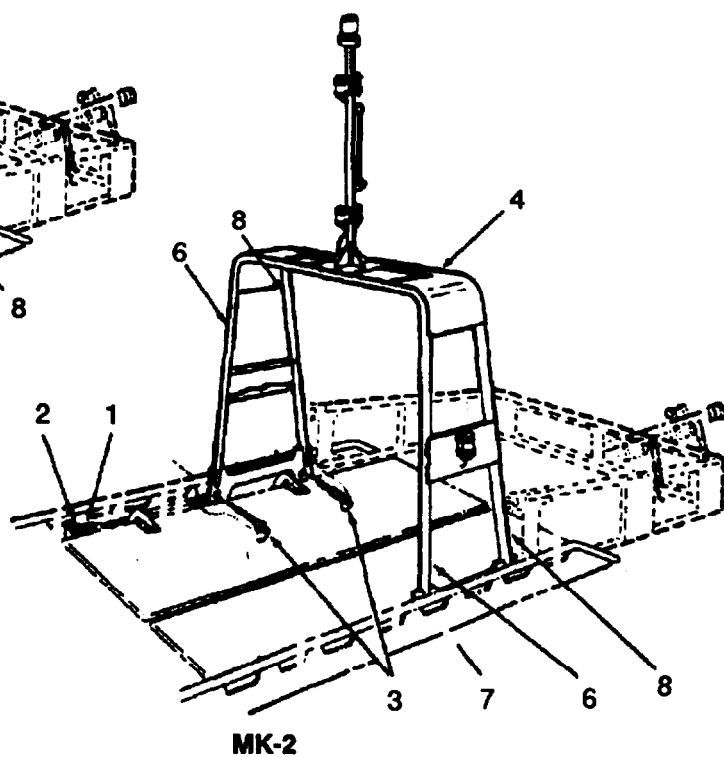
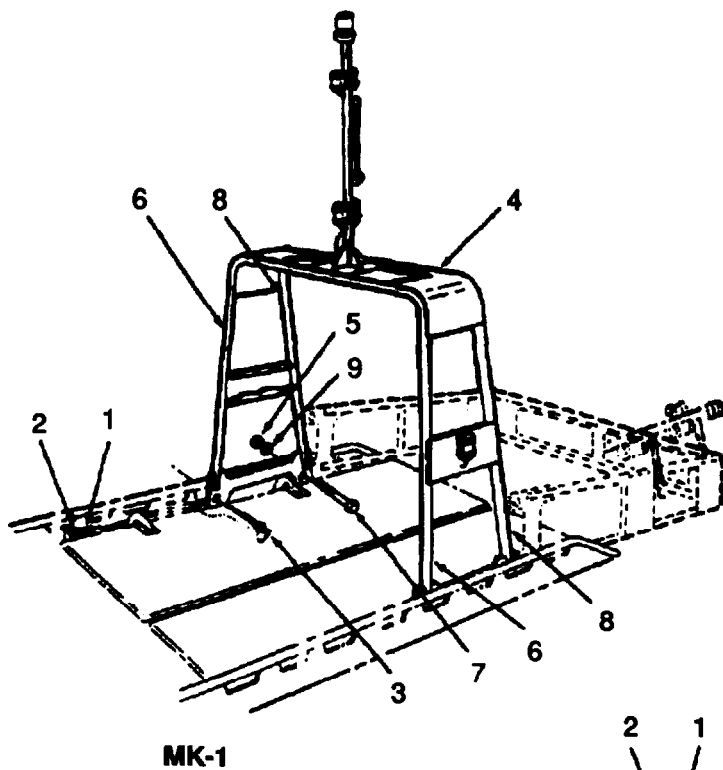

CAUTION

When disconnecting navigation light plug do not pull directly on wire. Damage may occur to wire.

1. Disconnect navigation light plug (1) from receptacle (2) on starboard side by grasping plug and pulling. Install protective caps over plug (1) and receptacle (2) and tie mast harness lead to mast.
2. Depress releases of two retaining pins (3) in forward legs (6) of mast (4) and remove pins.
3. Lower mast (4) toward rear until upper portion of the mast (near towing lights) meets capstan.
4. On MK1, using two wrenches remove nut (5), washer (9) and bolt (7) from aft mast legs (8). On MK2, depress the two retaining pins (3) to release the aft mast legs (8).
5. Remove mast (4) from boat.

INSTALL:

1. Position mast (4) on deck in lowered position making sure mast harness plug is on starboard side.
2. Aline holes in aft legs (8) of mast with the holes in aft mounting brackets.
3. On MK1, install bolts (7), washers (9) and nuts (5) in aft legs (6). On MK2, press the two quick release retaining pins (3) into position through aft mast legs (8).
4. Raise mast (4) to upright position and aline holes in forward legs (9) with holes in forward mounting brackets.
5. Install two retaining pins (3) in forward legs (9).
6. Remove protective caps from plug (1) and receptacle (2).
7. Connect navigation light plug (1) to receptacle (2).

3-9. CAB ASSEMBLY REPAIR INSTRUCTIONS**TOOLS: Putty Knife****PARTS/MATERIALS: Windshield Panel
Rubber Molding Insert
Rubber Molding
Soap and Water Solution (Item 5, Appendix C)**

Cab assembly should be removed from boat to make repairs. Personnel Injury could result.

REMOVE:

1. Remove cab assembly (refer to paragraph 3-10).

REPAIR WINDSHIELD AND SIDE PANELS**NOTE**

If replacing windshield panel iii windshield wiper Made and arm and secure.

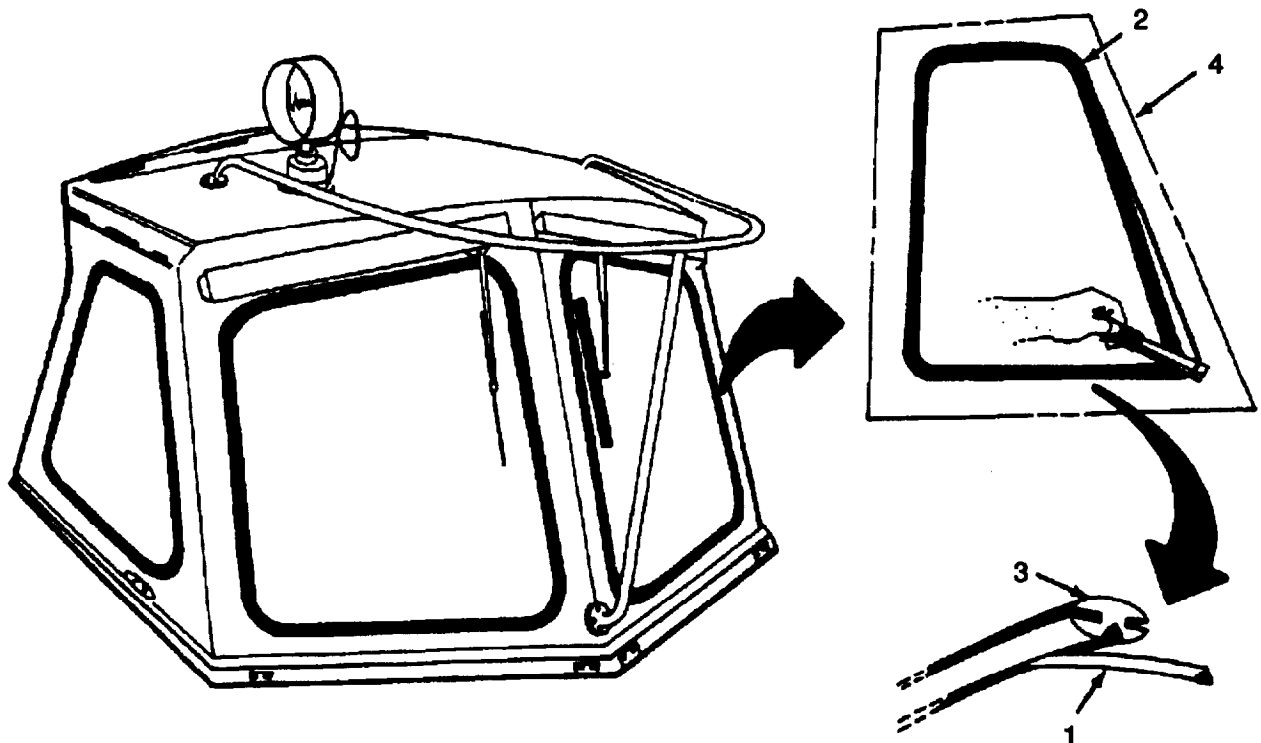

NOTE

Insert not used on some rubber molding.

1. Using putty knife, remove rubber molding insert (1) from window molding (2) (located on outside of cab).
2. Using putty knife, start at corner of windshield panel (3) and pry panel loose from rubber molding (2).
3. Remove rubber molding (2).
4. Discard rubber molding (2) and rubber molding insert (1).

INSTALL:

1. Measure and cut rubber molding insert (1) and rubber molding (2) to proper length.
2. Using soap and water solution, wet new rubber molding.
3. Install rubber molding (2) onto windshield panel frame (4) with slot for insert (1) located on outside of windshield (3).
4. Install new windshield panel by starting in one corner of frame (4) and applying sufficient force to seat panel (3) into rubber molding (2).

NOTE

Insert not required with some rubber molding.

5. Install new rubber molding insert (1).
6. Reposition windshield wiper blade and arm.
7. Install cab assembly (refer to paragraph 3-10).

3-10. CAB ASSEMBLY REPLACEMENT INSTRUCTIONS

TOOLS: None

PARTS/MATERIALS: Cab Assembly
Adhesive, Rubber Base
General Purpose
Rubber Sheet

PERSONNEL REQUIRED: Three

REMOVE:

1. Remove searchlight (refer to paragraph 3-97).

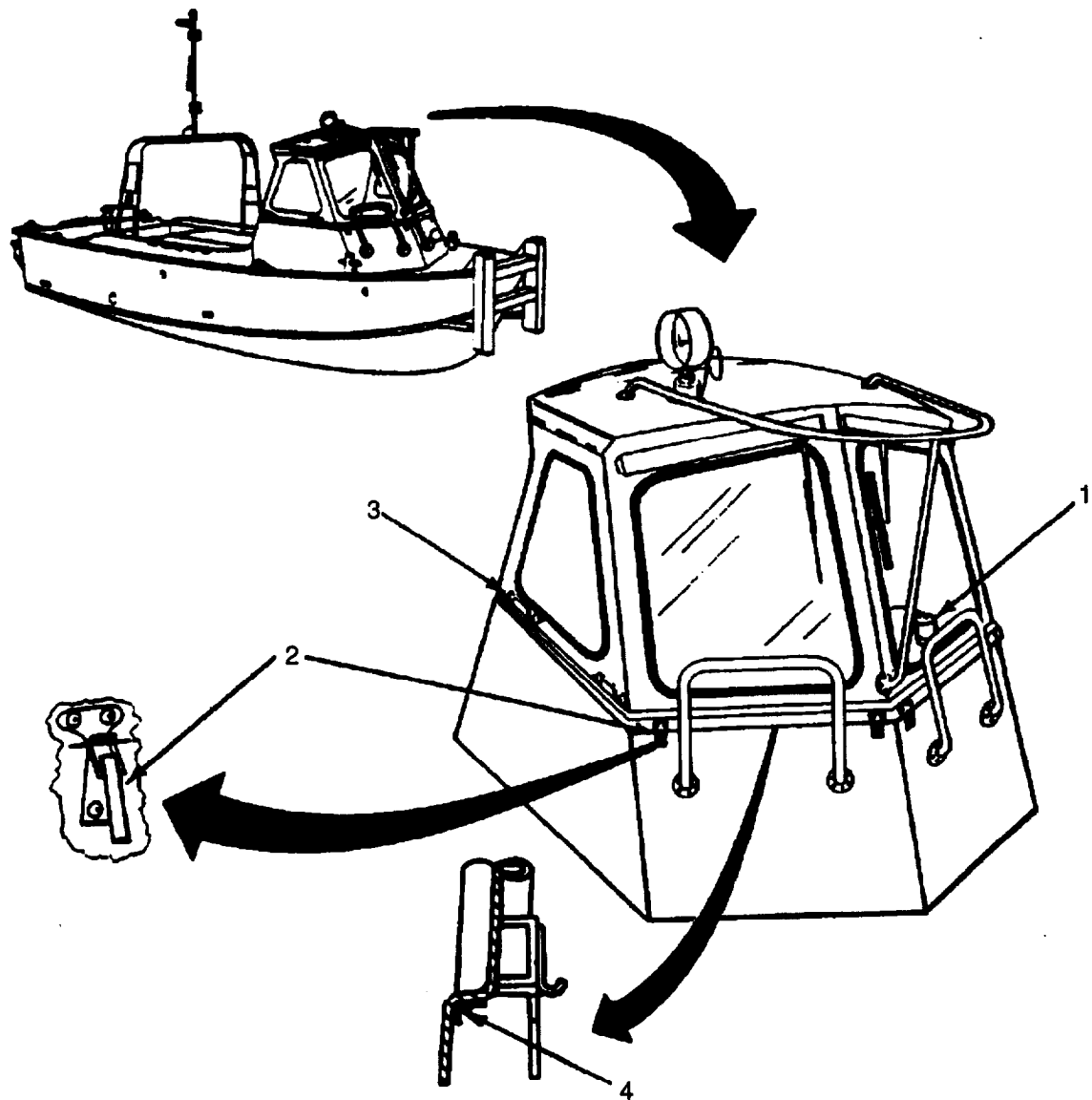

2. Disconnect windshield wiper electrical plug (1) from receptacle at center of control panel.
3. Release six toggle fasteners (2) which secure cab to deck.

NOTE

Four fasteners are located outside on forward warning and two fasteners are located inside cab rear port and starboard.

4. Using four cab lifting handles (3) lift cab to clear engine, transmission and scoop controls. Remove cab from boat.

INSPECT:

Inspect rubber seal around cab enclosure for damage. If necessary remove existing rubber strip (4) and apply a 1-inch strip of rubber (Item 20, App. C) with rubber adhesive (Item 21, App. C) to the cab mounting joint the total length of cab.

INSTALL:

1. Position cab on boat using four lifting handles (3).
2. Aline cab clamping fasteners (2) and close clamp fasteners (2).
3. Connect windshield wiper electrical plug (1) to receptacle at center of control panel.
4. Install searchlight (refer to paragraph 3-97).

3-11. WINDSHIELD WIPER BLADE REPLACEMENT INSTRUCTIONS

TOOLS: Needle Nose Pliers

PARTS/MATERIALS: Windshield Wiper Blade
1/16 inch Cotter Pin

REMOVE:

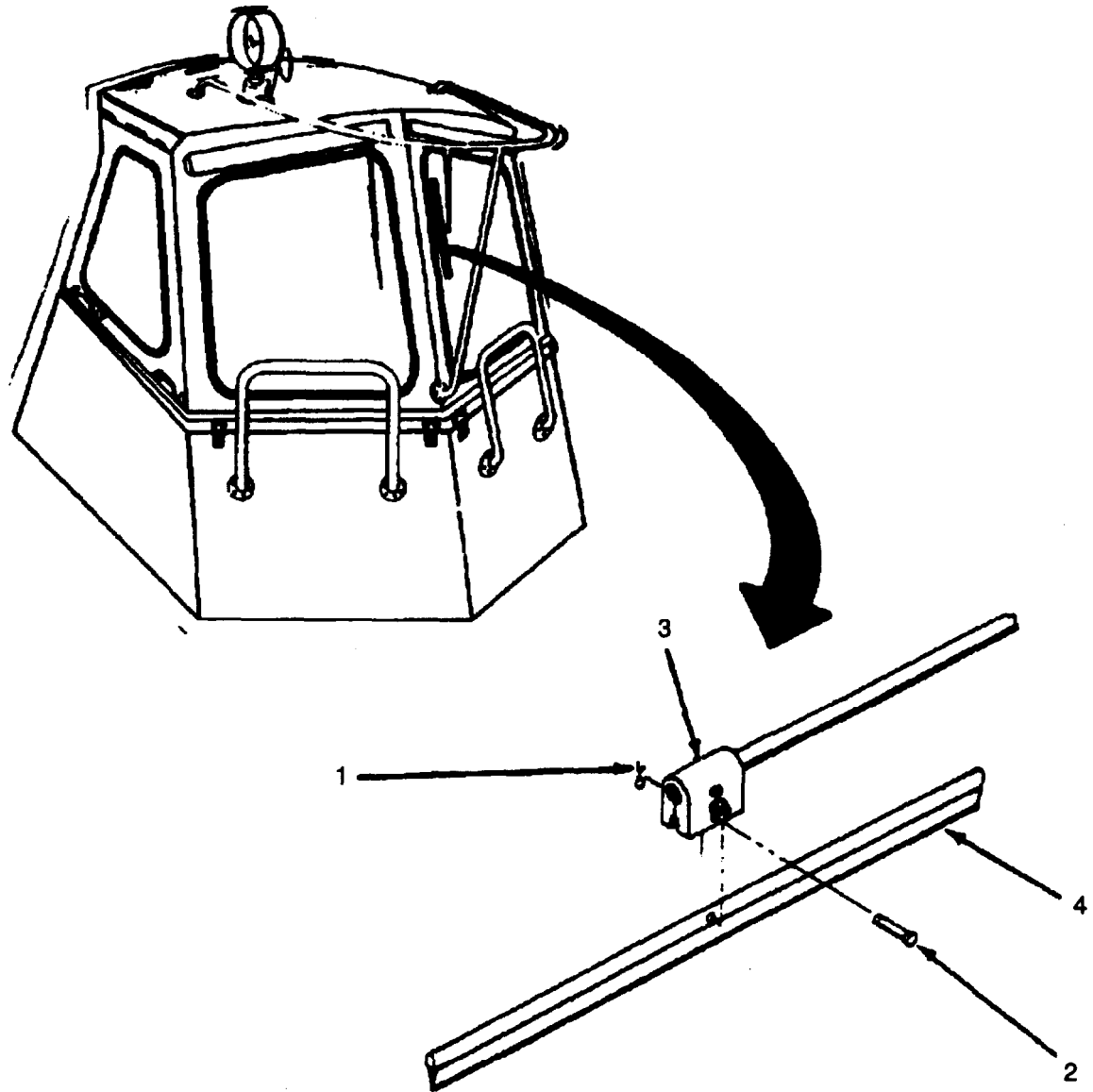

1. Remove cotter pin (1) from wiper blade holding pin (2) located on wiper arm connector (3).
2. Remove holding pin (2) from connector (3) and wiper blade (4).
3. Wiper blade will now separate from connector.

INSTALL:

1. Place new wiper blade (4) into mounting slot of connector (3).
2. Aline hole of wiper blade (4) with hole in connector (3).
3. Insert holding pin (2) through connector (3) and blade (4).
4. Insert new cotter pin (1) into end of holding pin (2).
5. Spread end of cotter pin (1).

3-12. WINDSHIELD WIPER MOTOR REPLACEMENT INSTRUCTIONS.

TOOLS: 7/16 inch Box Wrench

PARTS/MATERIALS: Windshield Wiper Motor

REMOVE:

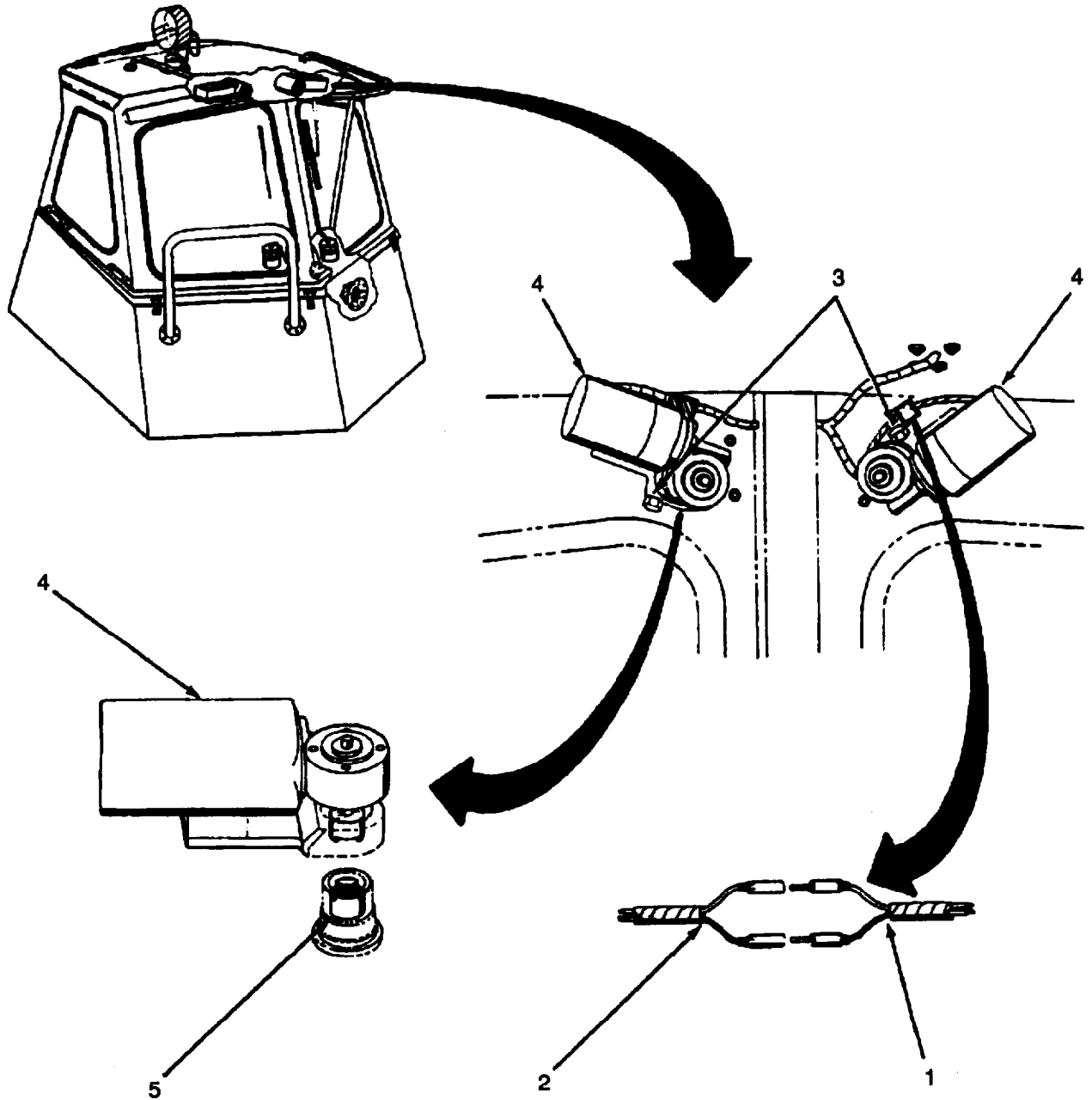

1. Tag and disconnect electrical leads (1) from wiper motor at connectors (2).
2. Loosen wiper motor holding bolt (3) using wrench.
3. Slide wiper motor (4) from drive unit flange (5).

INSTALL:

1. Position replacement motor (4) on windshield wiper drive unit flange (5) as shown in figure and align drive mechanism.
2. Tighten motor holding bolt (3) using wrench.
3. Connect electrical leads (1) to connectors (2).

NOTE

Do not run wiper on dry windows for more than one or two strokes. Wiper blades and/or windshield may be damaged. Wet down windshield if further testing is needed.

3-13. WINDSHIELD WIPER DRIVE UNIT REPAIR INSTRUCTIONS.

TOOLS: 5/32 inch Box Wrench
1/4 inch Socket
3/16 inch Hex Key (Allen)
Needle Nose Pliers
Ratchet

PARTS/MATERIALS: Wiper Drive Belt

REMOVE:

1. Remove windshield wiper drive unit (refer to paragraph 3-14).

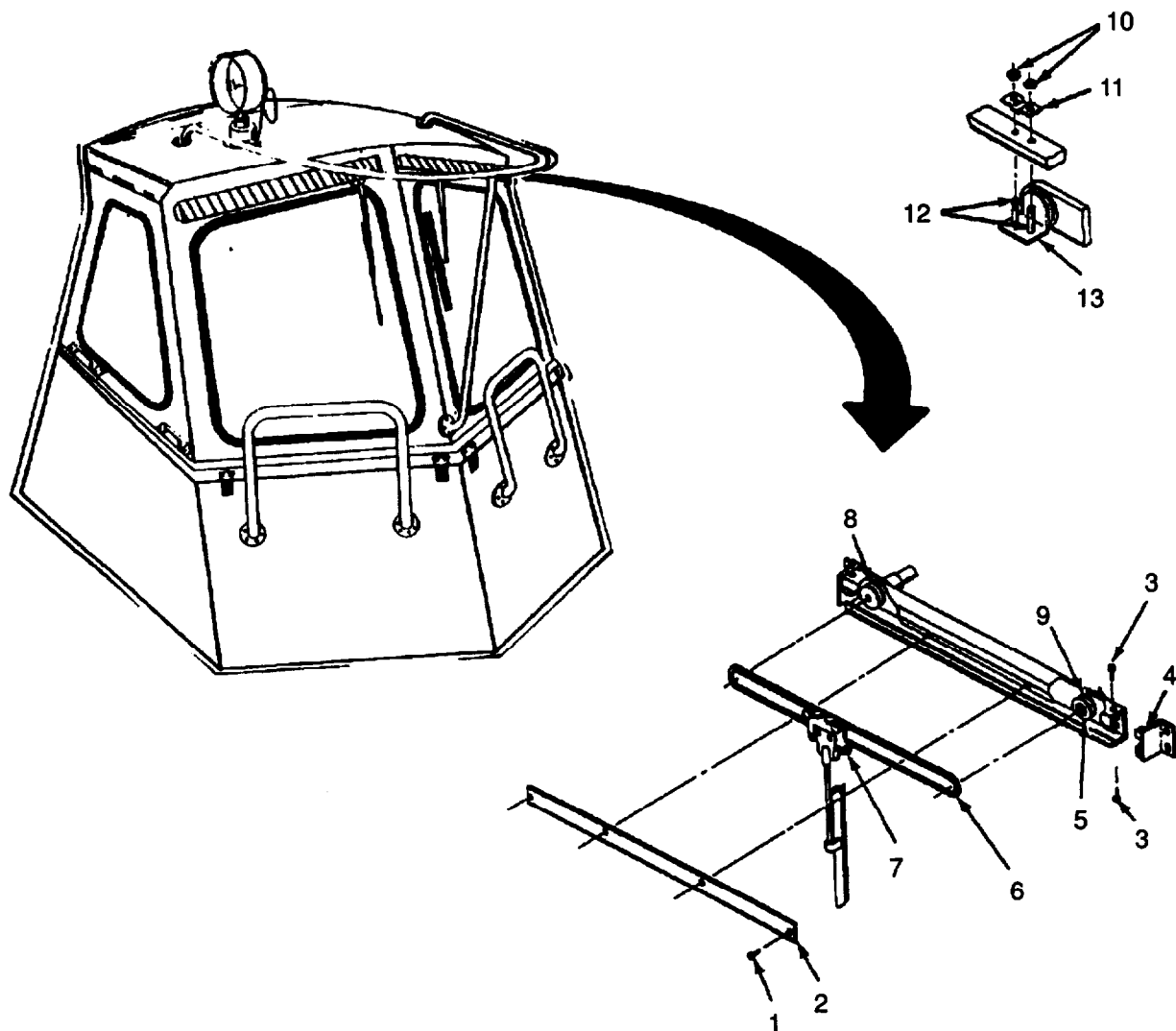

DISASSEMBLY:

1. Using socket remove four screws (1) securing front cover (2).
2. Remove cover (2).
3. Using socket remove two screws (3) securing end cover plate (4) on idler pulley end of wiper unit. Remove end plate (4).
4. Using hex key loosen idler pulley retaining screw (5) and release tension on drive belt (6).
5. Remove drive belt (6) and carriage assembly (7) from drive pulley (6) and idler pulley (9).
6. Remove carriage assembly (7) and drive belt (6) by sliding out through end cover plate (4) opening.
7. Using wrench remove two nuts (10) and holder (11) from two bolts (12) on support plate (13).
6. Carefully remove drive belt (6) from carriage assembly (7).

ASSEMBLE:

CAUTION

Do not lubricate wiper carriage, belt or rollers. Rollers are self-lubricating. Any petroleum-based lubricants will damage belt.

1. Install drive belt (6), holder (11) and two nuts (10) on bolts (12) of support plate (13) and tighten using wrench.
2. Replace carriage assembly (7) on wiper unit by sliding in through end cover plate opening (4).
3. Position drive belt (6) around drive pulley (6) and idler pulley (9).
4. Apply tension to tighten drive belt (6) by pulling idler pulley (9) in its slot away from drive pulley (6) and tighten idler pulley retaining screw (5) using hex key.
5. Replace end cover plate (4), install two retaining screws (3) and tighten using socket.
6. Replace front cover plate (2), install four retaining screws (1) and tighten using socket.

INSTALL:

Replace windshield wiper drive unit (refer to paragraph 3-14).

3-14. WINDSHIELD WIPER DRIVE UNIT REPLACEMENT INSTRUCTIONS

TOOLS: 7/16 inch Box Wrench
Small Flat Tip Screwdriver
Two 13 mm Box Wrenches

PARTS/MATERIALS: Windshield Wiper Drive Unit
Shaft Sealing Grommet
Sealant Compound

PERSONNEL REQUIRED: Two

REMOVE:

1. Remove windshield wiper motor (refer to paragraph 3-12).

NOTE

Removal of the windshield wiper drive unit requires two persons, one working outside the cab and the other inside the cab.

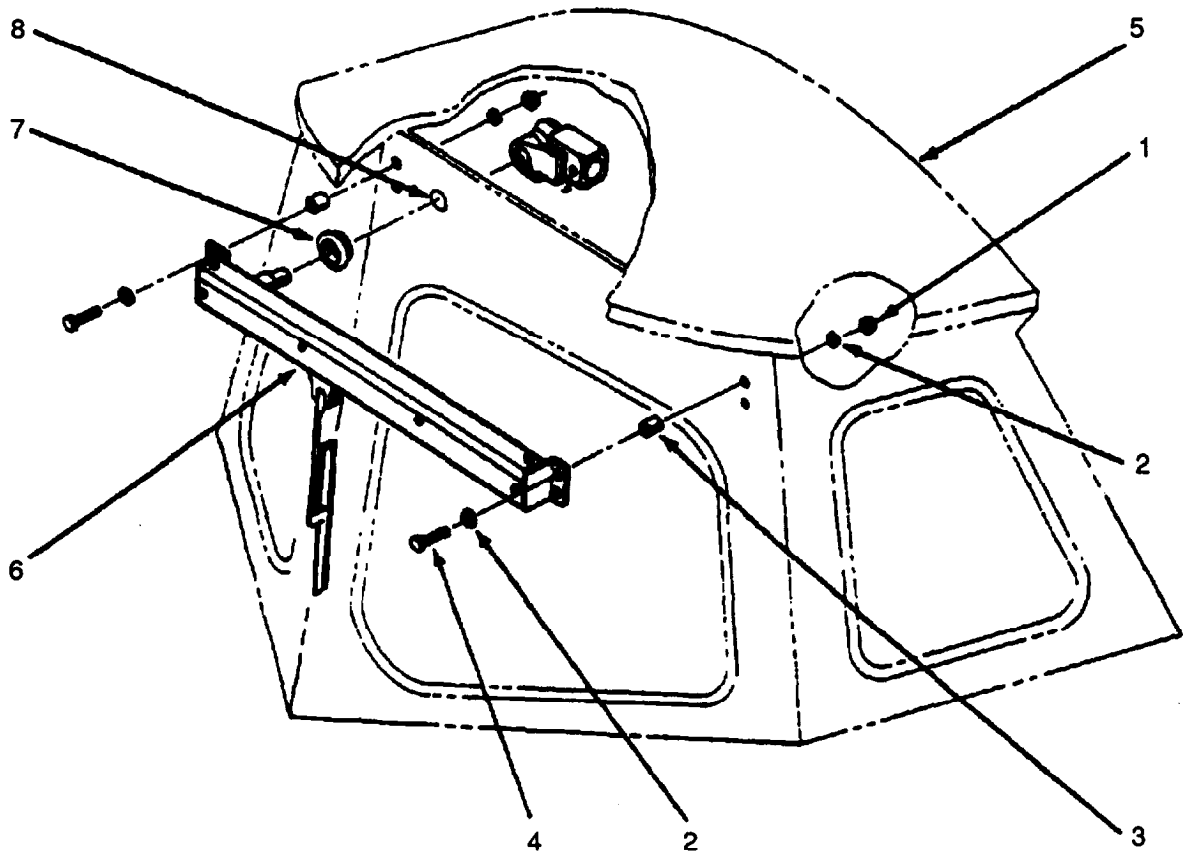

2. Using two 13 mm box wrenches, with one person working Inside cab and one person working outside cab, remove four units (1), eight washers (2), four spacers (3), and four bolts (4) securing drive unit to cab (5).
3. Remove drive unit (6) from cab (5) by pulling straight out from sealing grommet (7) fitted into drive access hole (8) in cab (5).
4. Remove grommet (7) from hole (8) in cab (5).

INSTALL:

1. Place new shaft sealing grommet (7) into drive access hole (8) with its flange towards back of wiper drive unit (6).
2. Place a thin coat of sealant, Item 22, App. C, to inside of grommet (7) to assist in shaft installation.
3. Place wiper drive unit (6) into position, ensuring that drive shaft fully enters sealing grommet (7) without disturbing its position in drive access hole.
4. Install four washers (2) on four bolts (4) and insert bolts thru wiper drive unit (6), spacers (3) and cab (5).
5. On inside of cab install four washers (2) and four nuts (1). Tighten using two 13 mm wrenches, taking the following precautions:
 - a. Casing is not twisted or bent during bolting down.
 - b. Sealing grommet is even on drive shaft and pressed firmly into drive access hole to make a watertight joint.
6. Install windshield wiper motor (refer to paragraph 3-12).

NOTE

Do not run wiper on dry windows for more than one or two strokes or wiper blades or Plexiglas windshield may be damaged. Wet down windshield if further testing is needed.

3-15. CAPSTAN ASSEMBLY SERVICING INSTRUCTIONS (MK1).

TOOLS: 3/16 inch Hex Key Wrench

PARTS/MATERIALS: Grease

DISASSEMBLE:

1. Remove handle (1) and set aside.
2. Remove four socket head screws (2) from cap (3) using wrench.
3. Lift cap (3) off shaft.
4. Remove split keeper (4).
5. Lift chain guide (5) off shaft.
6. Lift cover (6) off shaft.
7. Lightly grease gears (7 and 8) and bearings (9).

ASSEMBLE:

1. Reinstall cover (6) over shaft, meshing gears (7 and 8).
2. Reinstall chain guide (5) over shaft.
3. Reinstall split keeper (4) making sure keeper is completely seated in retaining groove on shaft.
4. Reinstall cap (3) over shaft.
5. Reinstall four socket head screws (2) using wrench.
6. Insert end of handle (1) into end of shaft.

3-16. CAPSTAN ASSEMBLY REPLACEMENT INSTRUCTIONS (MK1).

TOOLS: 15/16 inch Box Wrenches
3/16 inch Hex Key Wrench

PARTS/MATERIALS: Capstan Assembly

REMOVE:

1. Remove handle (1).
2. Remove tow hook (2). (Refer to paragraph 3-19).
3. Remove four socket head screws (3) from cap (4) using wrench.

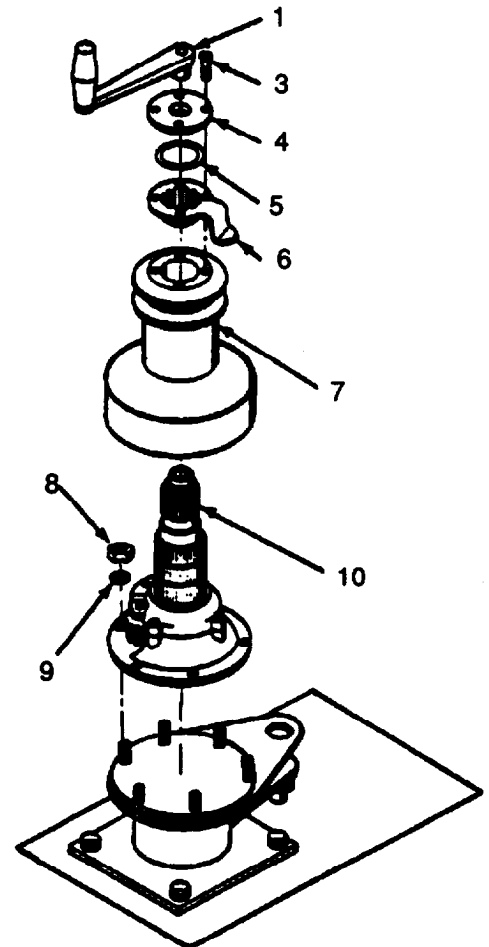
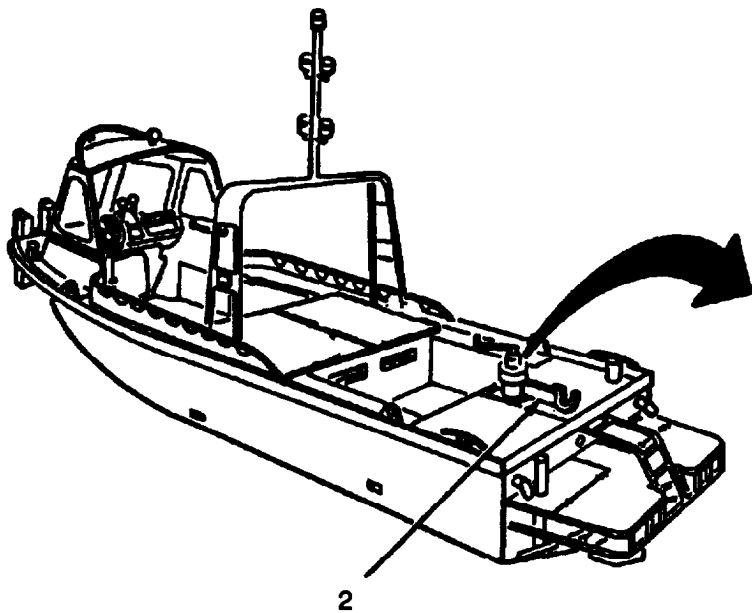

4. Lift cap (4) off shaft.
5. Remove split keeper (5).
6. Lift chain guide (6) off shaft.
7. Lift cover (7) off shaft.
6. Remove 5 nuts (6) and washers (9) from capstan base (10) using wrench.

INSTALL:

1. Install new capstan base (10) and secure washers (9) and nuts (6) using wrench.
2. Place cover (7) over shaft.
3. Place chain guide (6) over shaft.
4. Install split keeper (5).
5. Place cap (4) on shaft.
6. Install four socket head screws (3) securing cap (4) using wrench.
7. Install tow hook (2). (Refer to paragraph 3-19).
6. Insert end of handle (1) onto end of shaft.

3-17. CAPSTAN ASSEMBLY SERVICING INSTRUCTIONS (MK2 AND RETROFITTED MK1)

TOOLS: Drum Nut Wrench

PARTS/MATERIALS: Grease

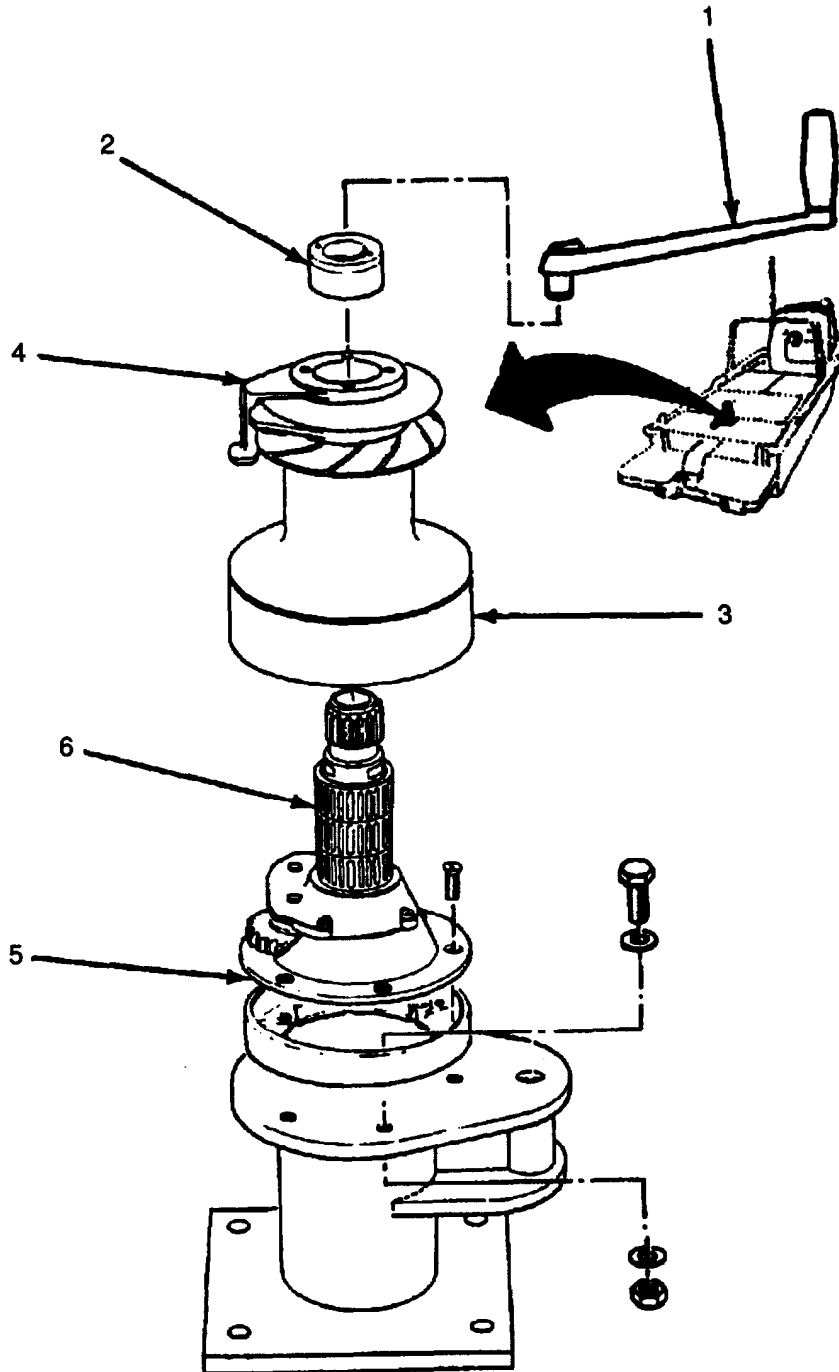

NOTE

MK2 capstans differ from those on MK1. MK1 boats are being retrofitted with the newer model capstan. Refer to paragraph 3-15 to determine which model capstan is fitted to boat.

DISASSEMBLE

1. Remove handle (1) and set aside.
2. Using drum nut wrench, remove drum nut (2).

CAUTION

Drum bearings may come off with drum. Do not let them fall out.

3. Lift drum (3) and line lifter (4) off gearbox assembly (5).
4. Lightly grease drum bearings (6).

ASSEMBLE

1. Place drum (3) and line lifter (4) on gearbox assembly (5).
2. Using drum nut wrench, install drum nut (2).
3. Install handle (1) on top of capstan.

3-18. CAPSTAN ASSEMBLY REPLACEMENT INSTRUCTIONS (MK2 AND RETROFITTED MK1)

TOOLS: Drum Nut Wrench
1/4 inch Hex Key Wrench
1/2 inch Box Wrench

PARTS/MATERIALS: Capstan Assembly

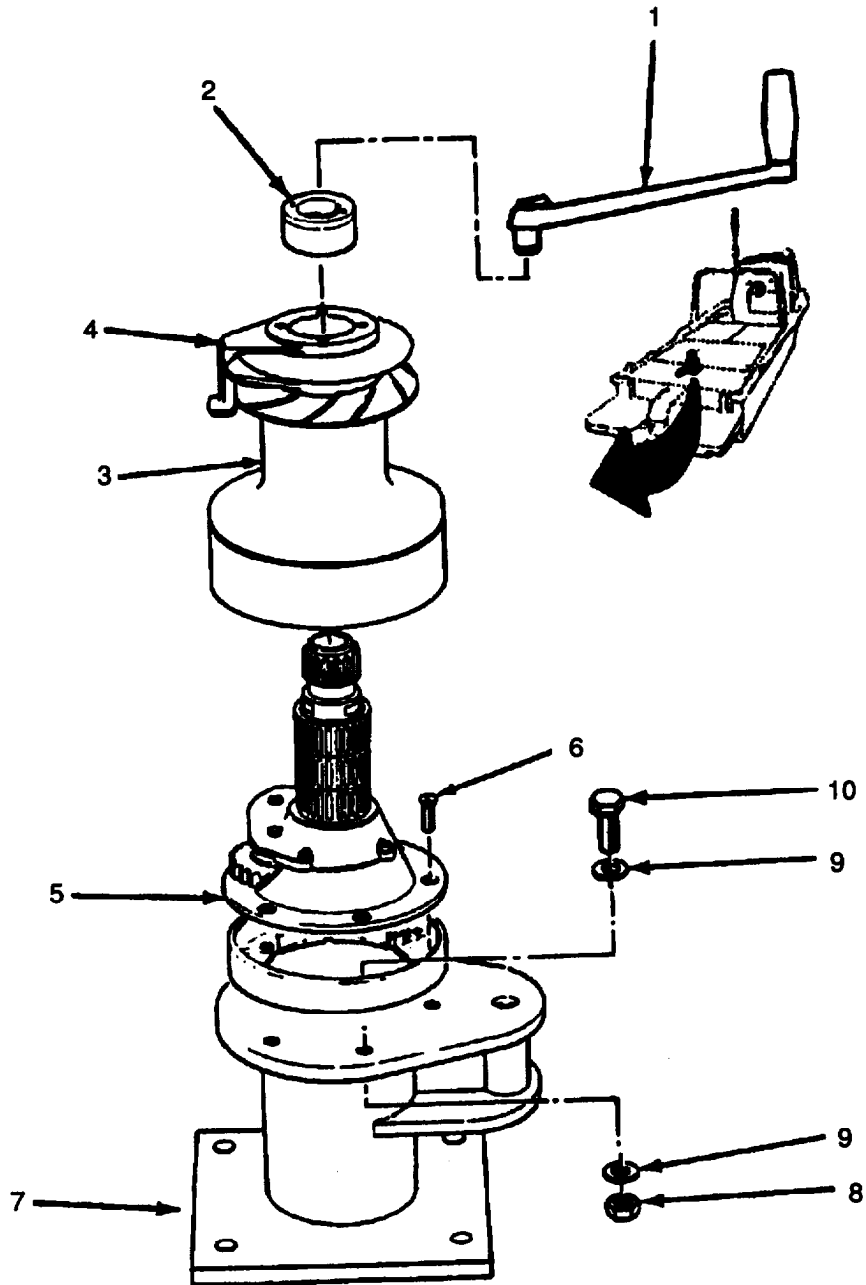

NOTE

MK2 capstans differ from those on MK1. MK1 boats are being retrofitted with the newer model capstan. Refer to paragraph 3-15 to determine if MK1 capstan is fitted to boat.

DISASSEMBLE:

1. Remove handle (1) and set aside.
2. Remove tow hook. (Refer to paragraph 3-19.)
3. Using a drum nut wrench, remove drum nut (2) by turning counterclockwise.

CAUTION

Drum bearings may come off with drum. Do not let them drop.

4. Remove drum (3) and line lifter (4) off gear box assembly (5).
5. Remove four capscrews (6) holding gearbox (5) to base (7).

NOTE

Main shaft may fall out when lifting gearbox assembly. Do not let it drop.

6. Remove gearbox assembly (5), keeping it intact.
7. Remove six locknuts (8), flatwashers (9), and screws (10) from base (7) and remove base.

ASSEMBLE:

1. Install base (7) using six screws (10), flatwashers (9), and locknuts (8).
2. Place gearbox assembly (5) on capstan base (7).
3. Secure gearbox assembly (5) to capstan base (7) using four capscrews (6).
4. Place drum (3) and line lifter (4) on gearbox assembly (5).
5. Using a drum nut wrench, install drum nut (2).
6. Install tow hook. (Refer to paragraph 3-19.)
7. Install handle (1) on top of capstan.

3-19. TOW HOOK REPLACEMENT INSTRUCTIONS (MK2 AND RETROFITTED MK1)

- TOOLS: 10 mm Combination Wrench
13 mm Combination Wrench
17 mm Combination Wrench
18 mm Combination Wrench
30 mm Combination Wrench
12 inch Open End Adjustable Wrench
Needle Nose Pliers
Pocket Knife
Hammer
Pin Punch

MATERIALS/PARTS: 7/16 inch Nylon Lanyard Matches

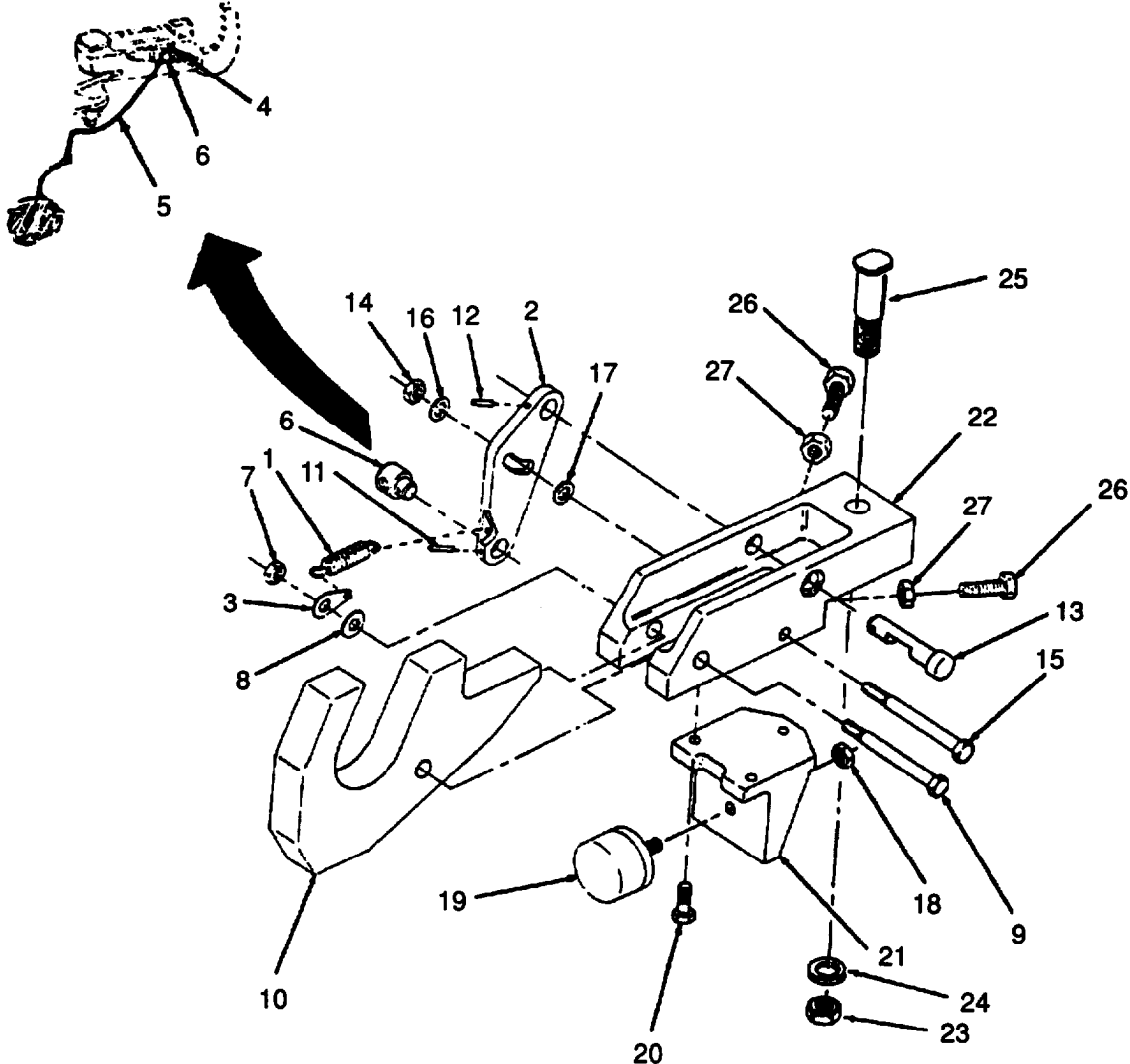

REMOVE:

1. Using needle nose pliers, remove spring (1) from quick-release lever (2) and spring retainer (3).
2. Untie knot (4) on end of lanyard (5) and remove lanyard from boss (6).
3. Using 18 mm combination wrench, remove nut (7) spring retainer (3), washer (8), and bolt (9) from tow hook assembly.
4. Supporting tow hook (10), remove bolt (9) and tow hook (10).
5. Using pin punch, remove two tubular pins (11) and (12). Remove boss (6) and slotted pin (13) from quick-release lever (2).
6. Using 13 mm combination wrench, remove nut (14), bolt (15), and two washers (16) and (17) and remove quick-release lever.
7. Using 10 mm combination wrench, remove nut (18) from circular buffer (19). Remove circular buffer.
8. Using 13 mm combination wrench, remove three socket-head screws (20) securing tow hook bracket (21) to tow hook body (22). Remove bracket.
9. Using 30 mm combination wrench and adjustable wrench, remove nut (23) and washer (24) from pin (25). Lift pin from tow hook body (22).
10. Remove tow hook body (22) from capstan foundation.
11. Using 17 mm combination wrench, remove two bolts (26) and nuts (27) from tow hook body (22).

INSTALL:

1. Locate two bolts (26) and two nuts (27). Using 17 mm combination wrench, screw one nut onto each bolt.
2. Using 17 mm combination wrench, screw bolts (26) with nuts into tow hook body (22).
3. Locate tow hook body (22) on capstan foundation and feed pin (25) through capstan foundation and tow hook body (22).
4. Using 30 mm combination wrench, secure washer (24) and nut (23) on pin (25).
5. Locate tow hook bracket (21) on tow hook body (22). Using 13 mm combination wrench, secure tow hook bracket (21) with three socket-head screws (20).
6. Locate circular buffer (19) on tow hook bracket (21). Using 10 mm combination wrench, secure circular buffer with nut (18).
7. Locate quick-release lever (2) on tow hook body (22). Using 13 mm combination wrench, secure quick-release lever with bolt (15), two washers (16) and (17), and nut (14).
8. Feed slotted pin (13) through tow hook body (22) and quick-release lever (2). Ensure slotted edge is facing down. Using hammer, drive tubular pin (12) into quick-release lever and slotted pin (13).
9. Locate tow hook boss (6) on quick-release lever (2). Using hammer, drive tubular pin (11) into quick-release lever (2) and boss (6).
10. Locate tow hook (10) on tow hook body (22). Feed bolt (9) through tow hook body and tow hook. Using 18 mm combination wrench, secure washer (8) spring retainer (3) and nut (7) to bolt (9).
11. Using needle nose pliers, install spring (1) between spring retainer (3) and quick-release lever (2).
12. Using pocket knife, cut 20 feet of rope for lanyard (5).
13. Use matches to melt ends of lanyard (5) to prevent fraying.
14. Tie one knot (4) five inches from end of lanyard (5) to prevent fraying.
15. Insert same end of lanyard (5) through hole in boss (6) and tie second knot on end so that lanyard does not slide out of bars.

3-20. TOW HOOK ASSEMBLY REPAIR INSTRUCTIONS (SPRING AND LANYARD REPLACEMENT- MK2 AND RETROFITTED MK1)

TOOLS: Needle Nose Pliers
Pocket Knife

PARTS/MATERIALS: Spring
7/16 inch Nylon Rope
Matches

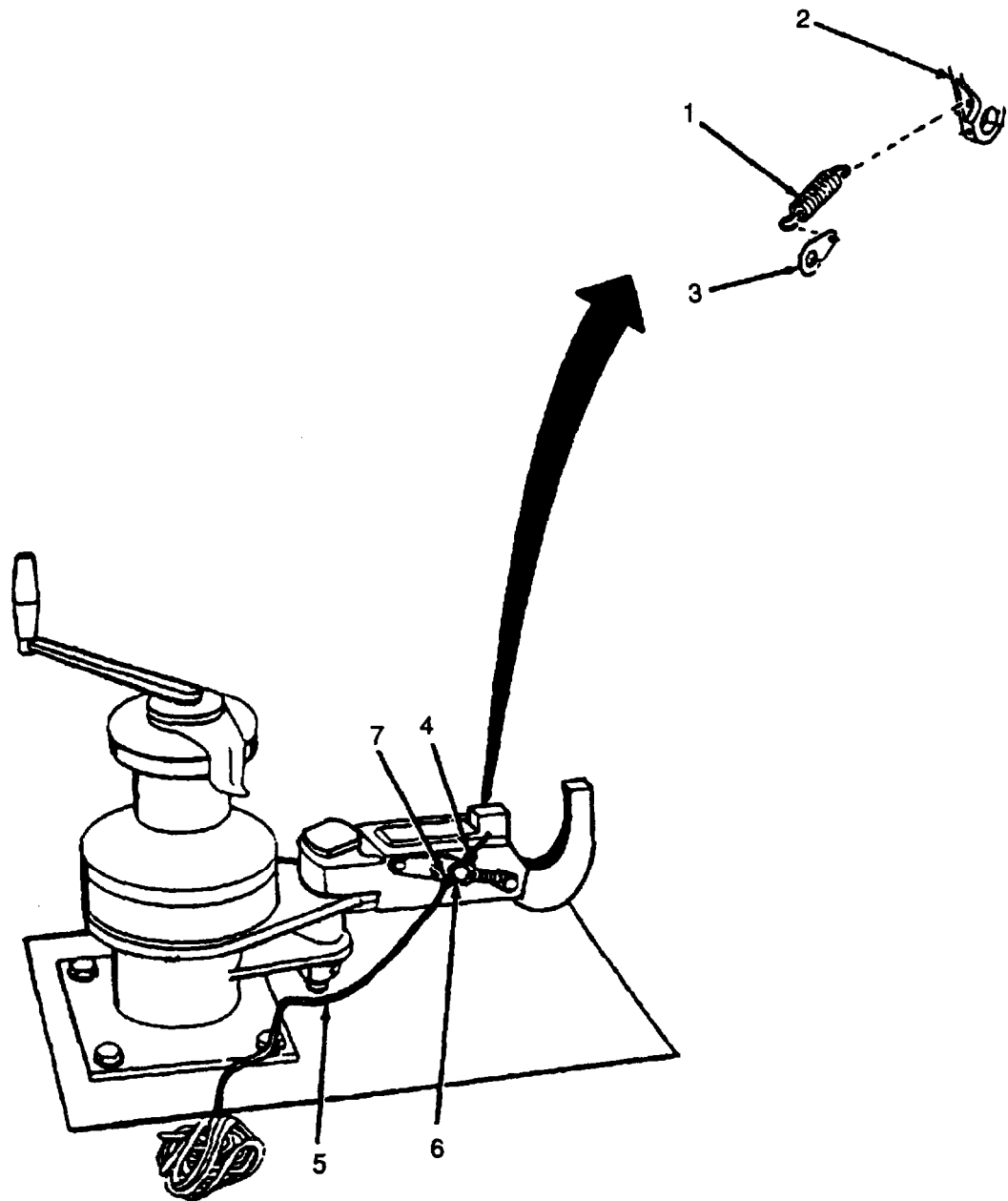

REMOVE:

1. Using needle nose pliers remove spring (1) from quick-release lever (2) and spring retainer (3).
2. Untie knot (4) on end of lanyard (5) and remove lanyard from boss (6).

INSTALL:

1. Using pocket knife cut 20 feet of rope for lanyard (5).
2. Use matches to melt ends of lanyard (5) to prevent fraying.
3. Tie one knot (7) five inches from end of lanyard (5) to prevent fraying.
4. Insert same end of lanyard (5) through hole in boss (6) and tie second knot (4) on end so that lanyard does not slide out of boss.
5. Using needle nose pliers install spring (1) on quick-release lever (2) and spring retainer (3).

3-21. PUSHKNEES REPAIR INSTRUCTIONS (MK1)

TOOLS: 3/4 inch Socket
Two 13 mm Sockets
Two Ratchets
3/4 inch Box Wrench
Two 6 inch Extensions
Electric Drill
1/2 inch Bit
1-1/4 inch Hole Cutter

PARTS/MATERIALS: Fender (Rub Rail) Section

REMOVE FENDER (RUB RAIL):

NOTE

Boat should be out of water on hard stand or cradle to repair pushknees.

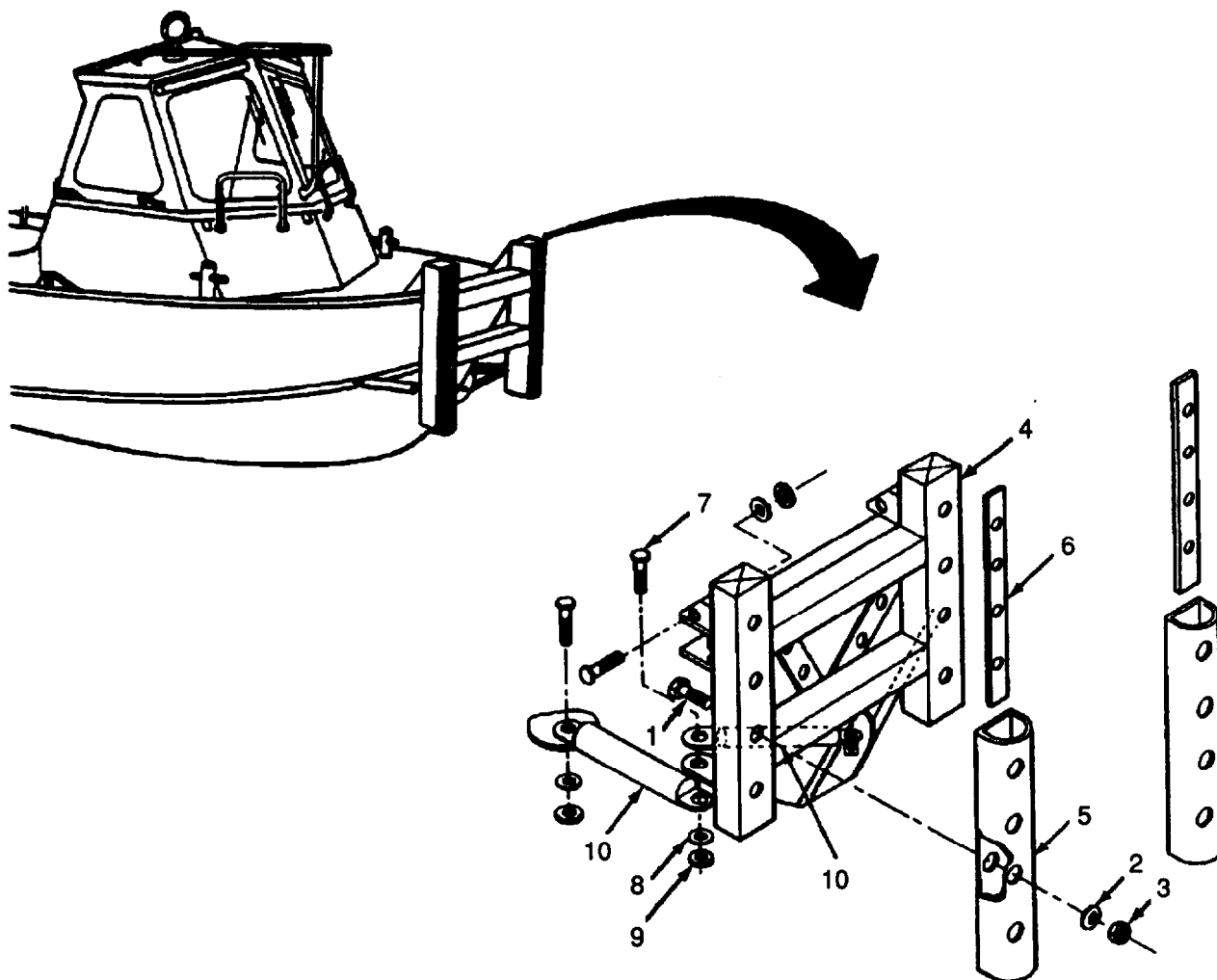

1. Using two 13 mm sockets, two ratchets and two extensions remove four bolts (1), washers (2), and nuts (3) securing rub rail section (5) to pushknees (4).
2. Remove fender (rub rail) sections (5) and metal insert (6).

INSTALL FENDER (RUB RAIL):

1. Lay metal insert on flat side of new rub rail and mark hole locations.
2. Using electric drill and 1/2 inch bit, drill 1/2 inch holes through flat side of rub rail.
3. Using electric drill and 1-1/4 inch hole cutter, cut holes through rub rail opposite 1/2 inch holes.
4. Install metal insert into rub rail section.
5. Using two 13 mm sockets, two ratchets and two extensions install four bolts (1), washers (2), and nuts (3) securing rub rail section to pushknees.

REMOVE BRACES:

1. Using 3/4 inch socket, ratchet and 3/4 inch box wrench remove two bolts (7), two washers (8) and two nuts (9).
2. Remove braces (10).

INSTALL BRACES:

1. Place braces (10) in position with bolt holes alined with brackets on pushknee and hull.
2. Install two bolts (7), two washers (8) and two nuts (9) using 3/4 inch socket, ratchet and 3/4 inch box wrench.

3-22. PUSHKNEES REPLACEMENT INSTRUCTIONS (MK1)

TOOLS: 3/4 inch Socket
Ratchet
3/4 inch Box Wrench

PARTS/MATERIALS: Pushknees

PERSONNEL REQUIRED: Two

REMOVE:

NOTE

Boat should be out of water on cradle or hardstand to replace pushknees.

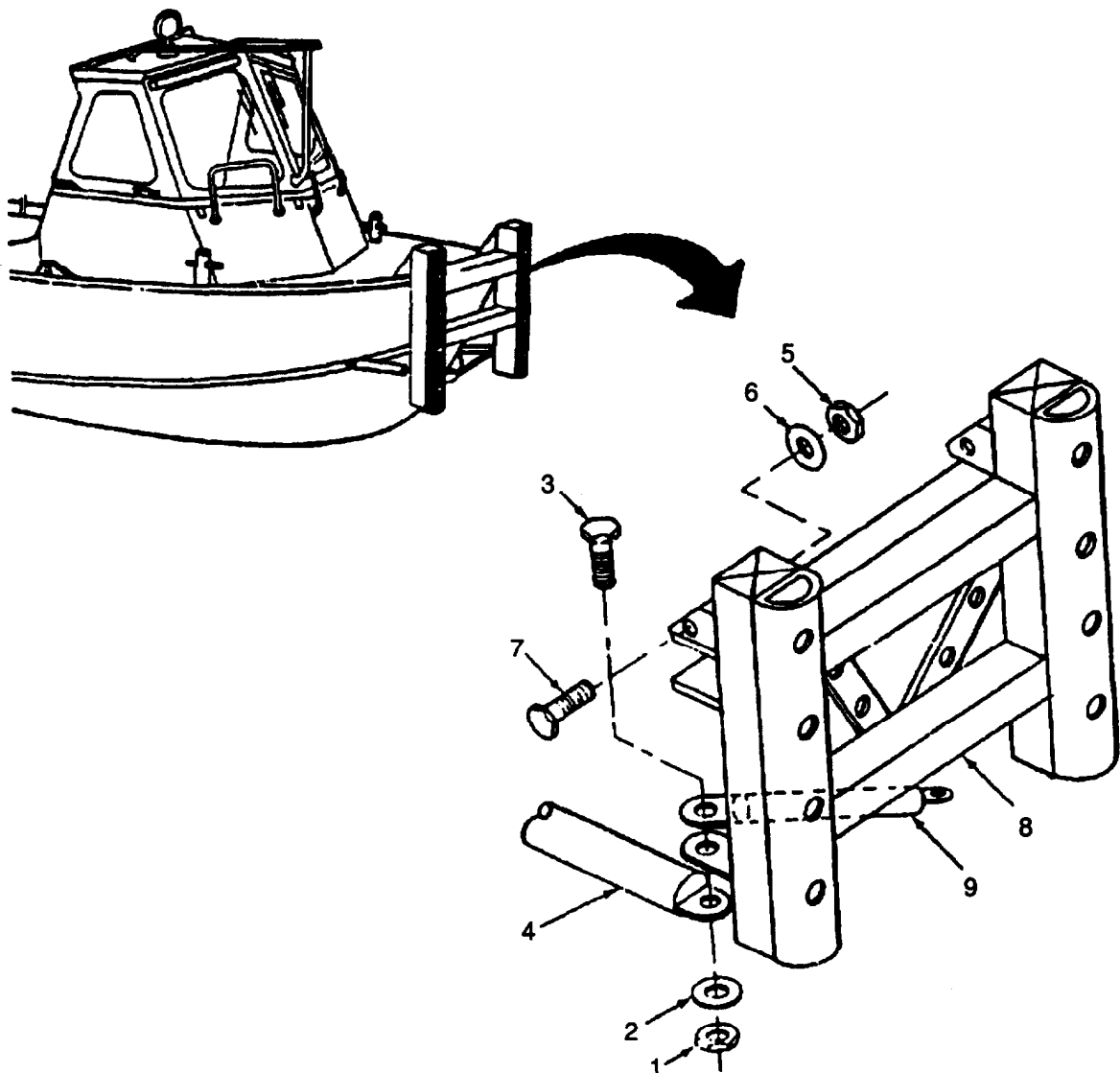

1. Using wrench and socket remove nuts (1), washers (2) and bolts (3) from stabilizer bars (4) and (9).
2. Using wrench and socket remove nuts (5) washers (6) and bolts (7) from deck mounting brackets.
3. Remove pushknees (8) from boat.

INSTALL:

1. Install pushknees (8) on bow of boat and aline deck mounting brackets.
2. Install bolts (7) to secure pushknees (8) in place.
3. Install washers (6) and nuts (5) and hand tighten.
4. Aline pushknees with stabilizer bars (9) on top and (4) on bottom of bracket. Install bolts (3), washers (2) and nuts (1) and hand tighten.
5. Install nuts (2 and 5) and tighten using wrench and socket.

3-23. PUSHKNEES REPAIR INSTRUCTIONS (MK2)

TOOLS: Two 13 mm Sockets
Two Ratchets
Two 6 inch Extensions
Electric Drill
1/2 inch Bit
1-1/4 inch Hole Cutter

PARTS/MATERIALS: Fender (Rub Rail) Section

REMOVE FENDER (RUB RAIL):

NOTE

Boat should be out of water on hard stand or cradle to repair pushknees.

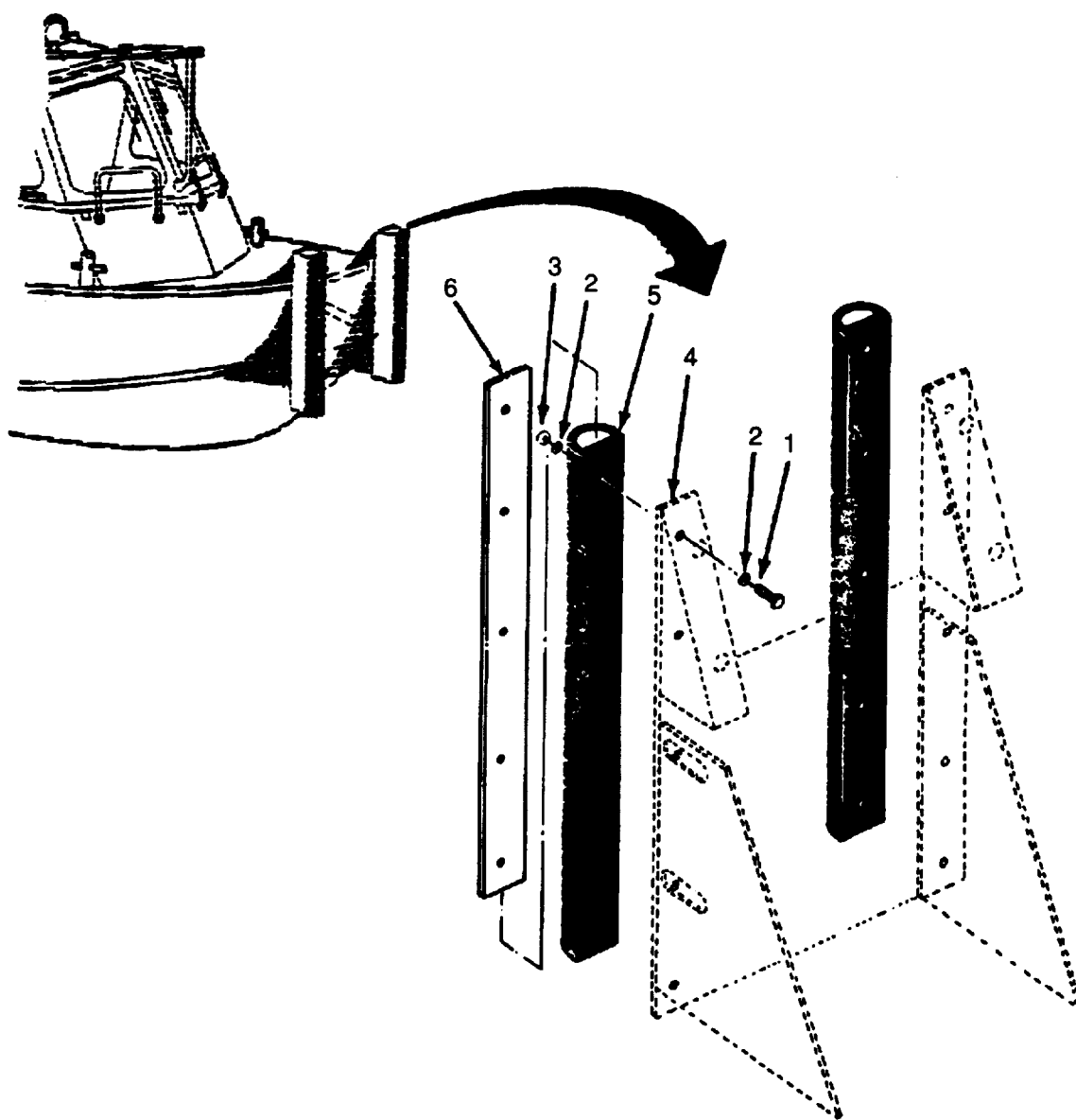

1. Using two 13 mm sockets, two ratchets and two extensions remove five bolts (1), washers (2), and nuts (3) securing rub rail section (5) to pushknees (4).
2. Remove fender (rub rail) sections (5) and metal insert (6).

INSTALL FENDER (RUB RAIL):

1. Lay metal insert on flat side of new rub rail and mark hole locations.
2. Using electric drill and 1/2 inch bit, drill 1/2 inch holes through flat side of rub rail.
3. Using electric drill and 1-1/4 inch hole cutter, cut holes through rub rail opposite 1/2 inch holes.
4. Install metal insert into rub rail section.
5. Using two 13 mm sockets, two ratchets and two extensions install five bolts (1), washers (2) and nuts (3) securing rub rail section to pushknees.

3-24. BATTERY HATCH COVER, HINGES, AND SUPPORT BRACE REPLACEMENT INSTRUCTIONS

TOOLS: Two 10 mm Box Wrenches

PARTS/MATERIALS: Battery Hatch Cover
Hinges
Adhesive Rubber Seal
Support Brace

REMOVE:

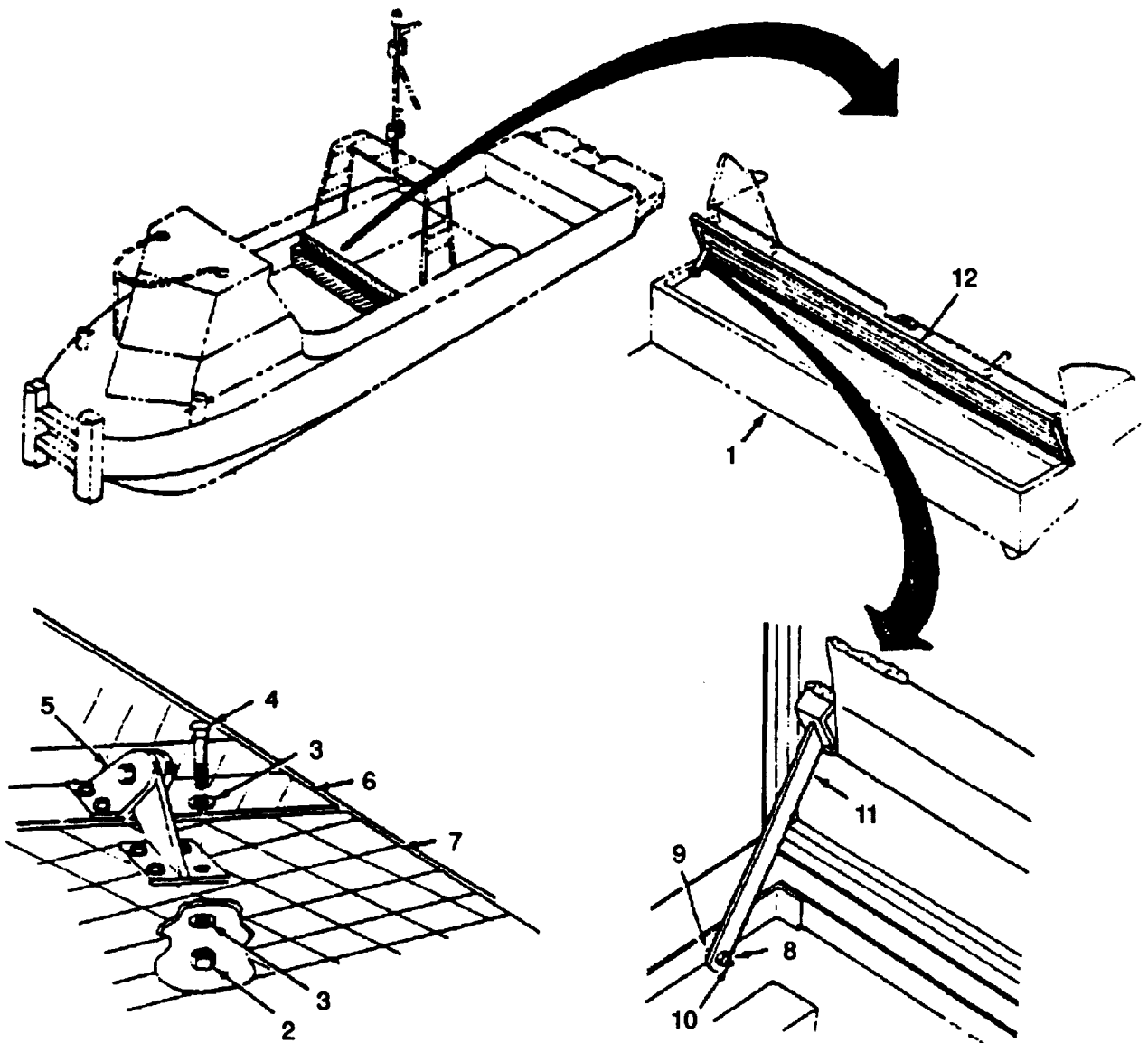

1. Open battery hatch (1) to half open position.
2. Remove 12 nuts (2), sixteen washers (3) and 12 bolts (4) from three hinges (5), hatch (6) and boat frame (7) using two wrenches.
3. Remove hinges and battery hatch.
4. Using two wrenches remove nut (8), washer (9) and bolt (10) securing battery hatch support brace (11) to boat frame.
5. Remove support brace.

INSTALL:

1. Install strip of adhesive rubber seal (12) around inside of battery hatch.
2. Replace support brace.
3. Using two wrenches install washer (9), bolt (10) and nut (8) securing support brace (11) to boat frame.
4. Fit new hinge assembly (5) to boat frame and align holes.
5. Install four bolts (4) and eight washers (3) through three hinge assembly and boat frame. Attach eight washers (3) and four nuts (2) and tighten using two wrenches.
6. Position new battery hatch (1) over battery compartment (insure hinge mounting holes are aft) then raise to half open position.
7. Align hinge holes with holes in battery hatch.
8. Install four bolts (4) and eight washers (3) through three hinge assemblies and battery hatch cover. Attach eight washers (3) and four nuts (2) and tighten using two wrenches.
9. Open and secure battery hatch (refer to paragraph 3-154).
10. Close battery hatch.

3-25. ENGINE HATCH COVER, HINGES, AND SUPPORT BRACE REPLACEMENT INSTRUCTIONS

TOOLS: Pliers

Two 13 mm Box Wrenches

PARTS/MATERIALS: Pins

Support Braces

Engine Hatches (Port or Starboard)

Hinges

Cotter Pins

PERSONNEL REQUIRED: Two

REMOVE:

1. Open and secure engine hatches (refer to paragraph 3-154).

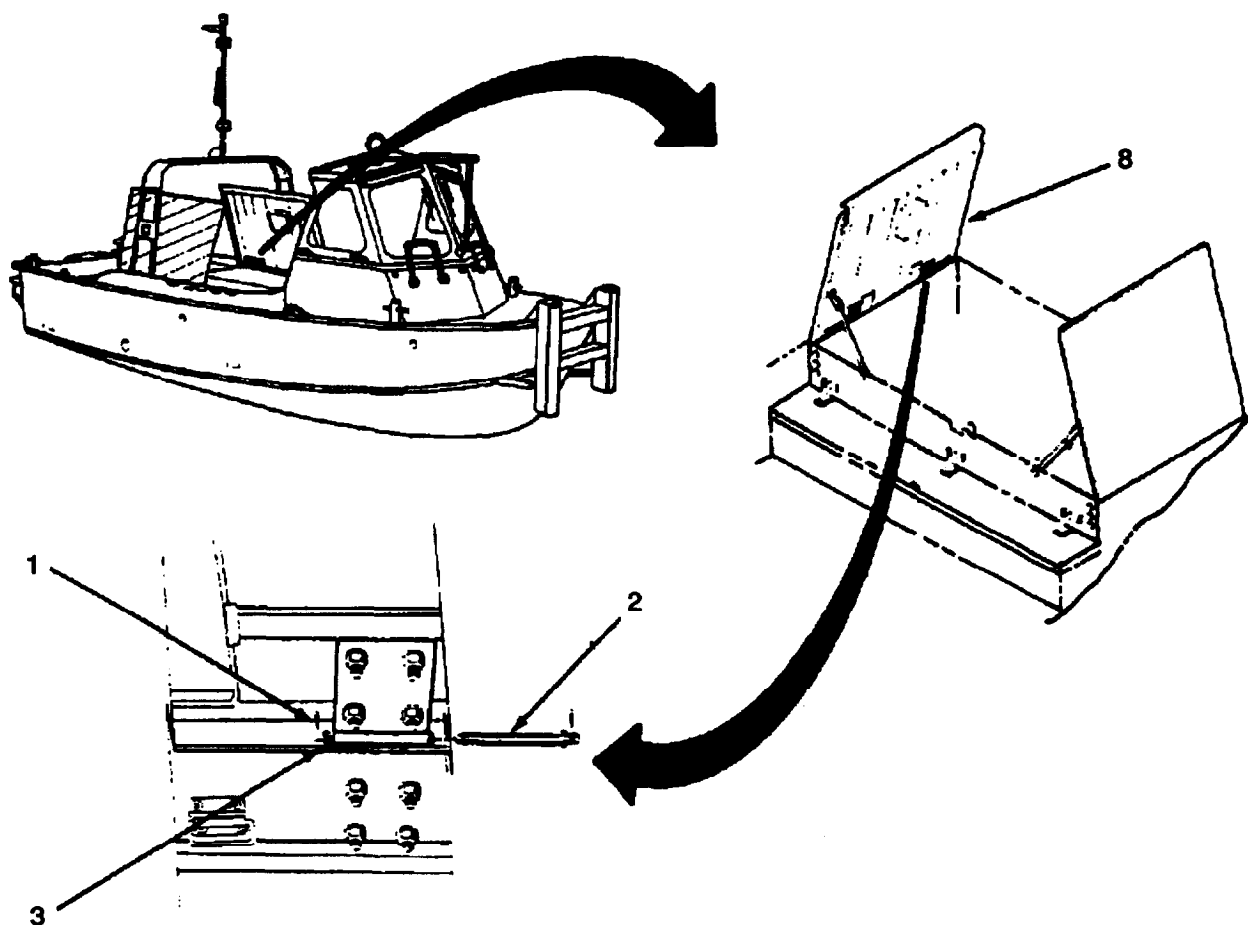

2. Using pliers straighten and remove cotter pins (1) from hinge connecting pins (2) fore and aft.
3. Remove washer (3) and connecting pins (2).
4. Remove pin (4) from retaining hole (5) and securing brace (6). Push hatch open to clear brace (6).
5. Remove securing brace (6) from grooved slot (7).
6. Swing securing brace (6) down into stored position.

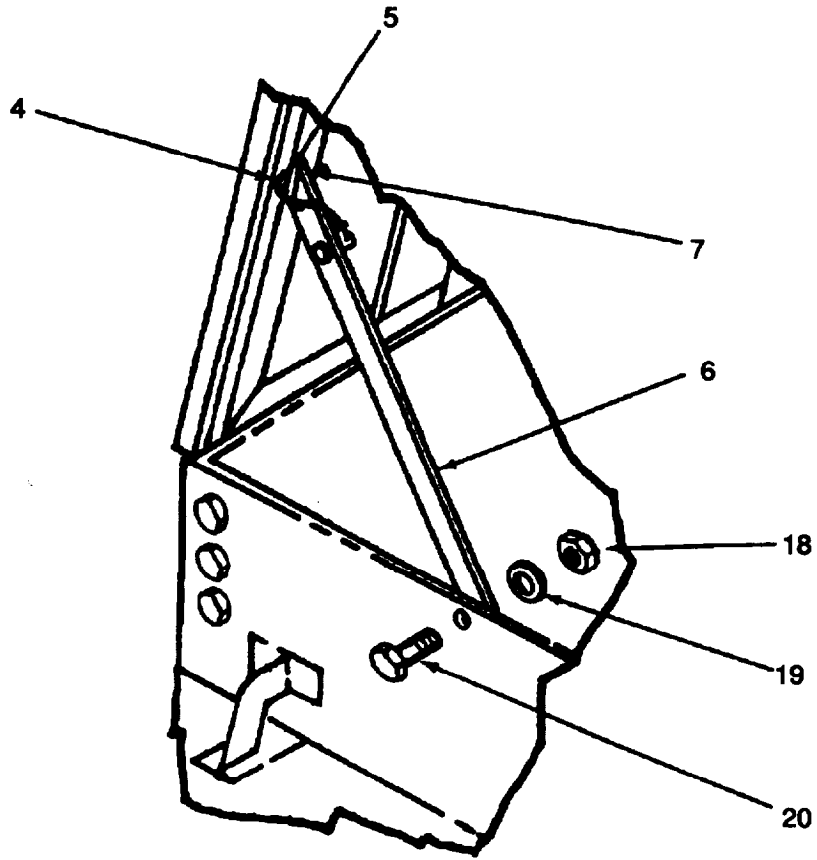

7. Remove engine hatch (8) from boat.

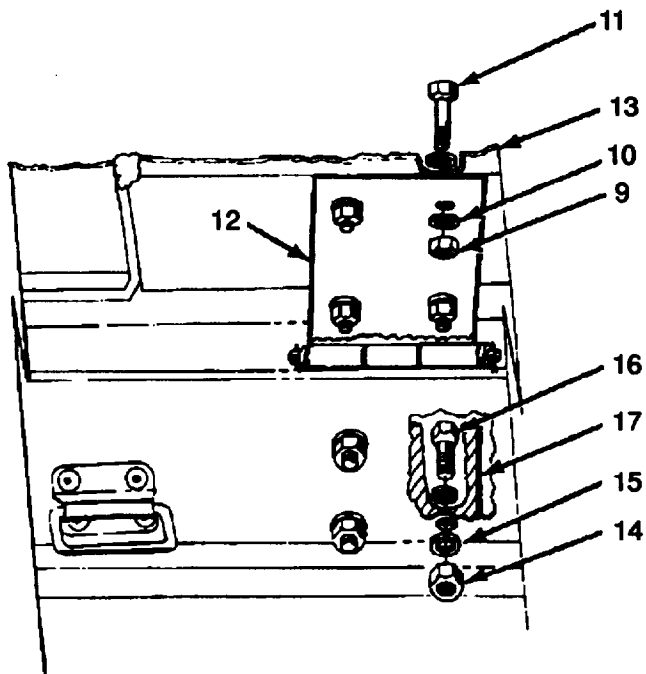

8. Using two wrenches remove nuts (9), washers (10) and bolts (11) from hinge plates (12) on hatch cover (13).
9. Using two wrenches remove nuts (14), washers (15) and bolts (16) from hinge plates (17) on boat frame.
10. Using two wrenches remove nut (18), washer (19) and bolt (20) securing support brace assembly (6) to boat frame.
11. Remove support brace assembly (6).

INSTALL:

1. Replace support brace assembly.
2. Using two wrenches install bolt (20), washer (19) and nut (18) securing support brace assembly (6) to boat frame.
3. Fit new hinge plate (12) to new hatch cover (13) and aline holes.
4. Install bolts (11) and washers (10) through hinge plate and hatch cover. Attach washer (10) and nut (9) and tighten using two wrenches.
5. Fit new hinge plate (17) to boat frame and aline holes.
6. Install bolts (16) and washers (15) through hinge plate (17) and boat frame. Attach washer (15) and nut (14) and tighten using two wrenches.
7. Fit hatch cover (13) (with hinge plates installed) to boat.
8. Aline hatch cover (13) with matching hinge plates on boat frame.
9. Insert hinge pins (2) and install washers (3) and new cotter pins (1).
10. Flare ends of cotter pins (1).
11. Close engine hatches.

3-26. HYDROJET HATCH COVER, HINGES, AND SUPPORT BRACE REPLACEMENT INSTRUCTIONS

TOOLS: Two 10 mm Box Wrenches

PARTS/MATERIALS: Hydrojet Hatch Cover
Support Braces
Hinges

REMOVE:

1. Open and secure hydrojet hatch (refer to paragraph 3-154).

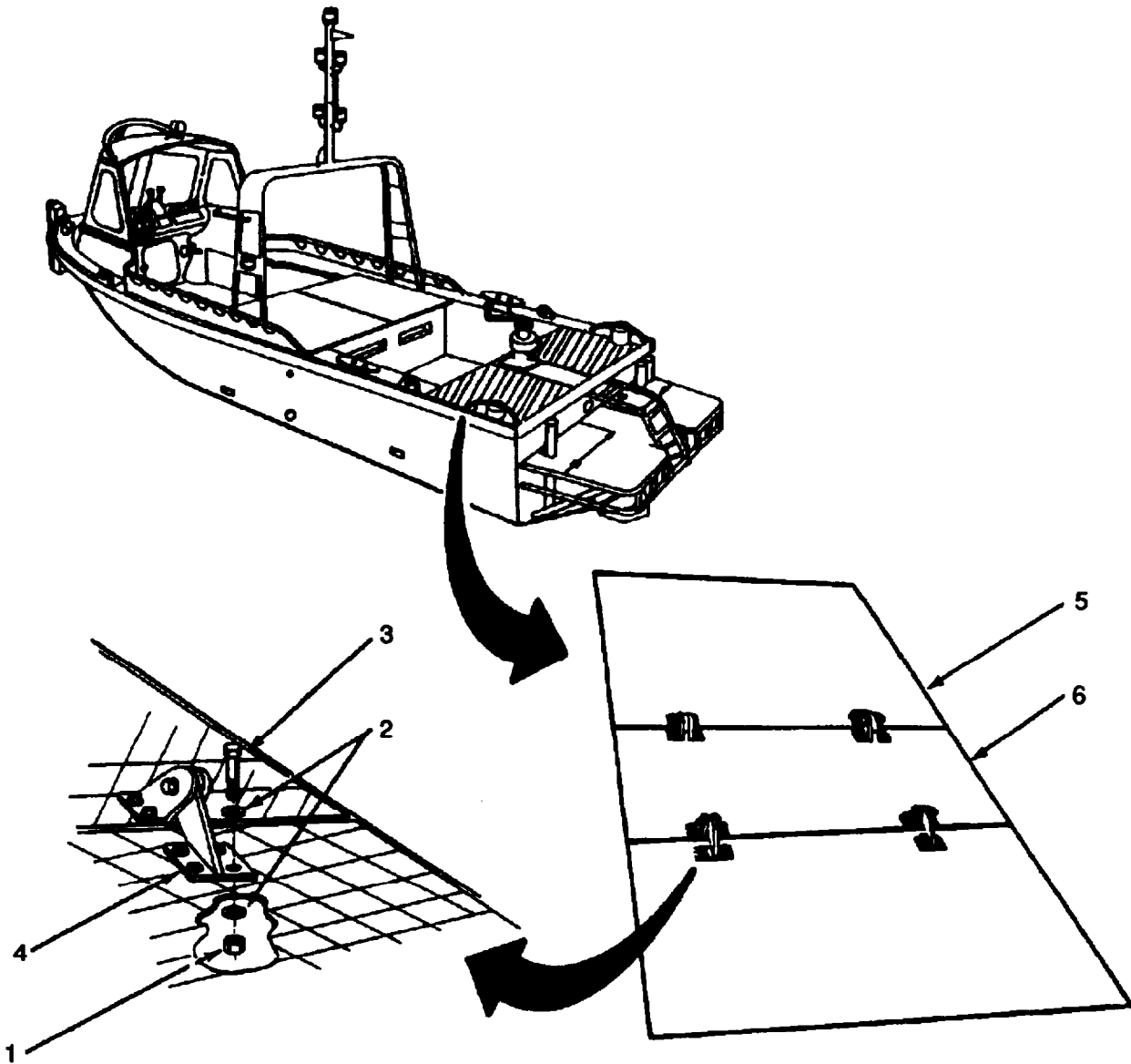

2. Using two wrenches remove 12 nuts (1), sixteen washers (2) and 12 bolts (3) from two hinges (4), hatch cover (5) and boat frame (6).
3. Remove hinges (4) and hydrojet hatch cover (5).

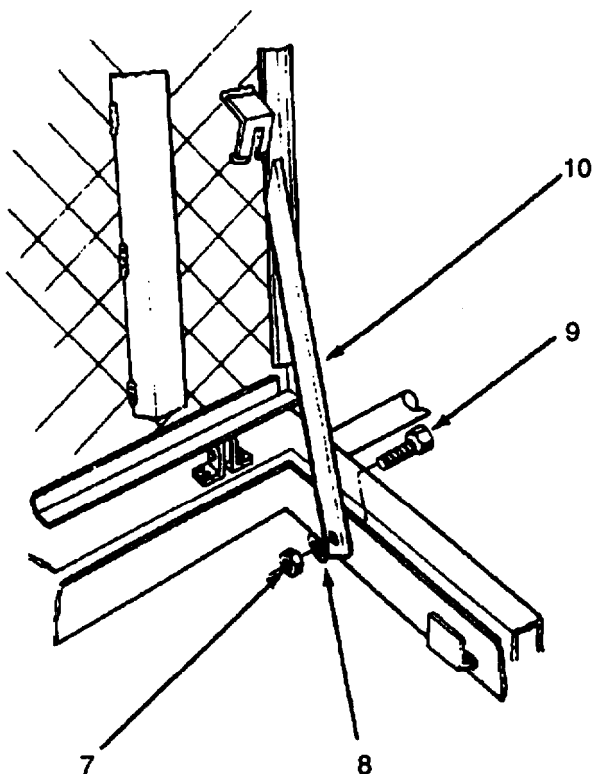

4. Using two wrenches remove nut (7), washer (8) and bolt (9) securing hydrojet hatch cover support brace (10) to boat frame.
5. Remove support brace (10).

INSTALL:

1. Replace support brace (10).
2. Using two wrenches install washer (8), bolt (9) and nut (7) securing support brace (10) to boat frame.
3. Position new hydrojet hatch cover (5) on boat aligning holes in hatch cover to holes on hinge. Hatch cover must be in open position.
4. Using two wrenches install 12 bolts (3), sixteen washers (2) and 12 nuts (1) securing new hinges (4) and hatch cover (5) to boat frame. Make sure slotted hinge is attached to boat frame.
5. Close hydrojet hatch cover.

3-27. AFT COCKPIT REPLACEMENT INSTRUCTIONS

TOOLS: Flat Tip Screwdriver, 4 inch
17 mm Box Wrench

PARTS/MATERIALS: Aft Cockpit

PERSONNEL REQUIRED: Three

REMOVE:

1. Open and secure hydrojet hatch covers (refer to paragraph 3-154).

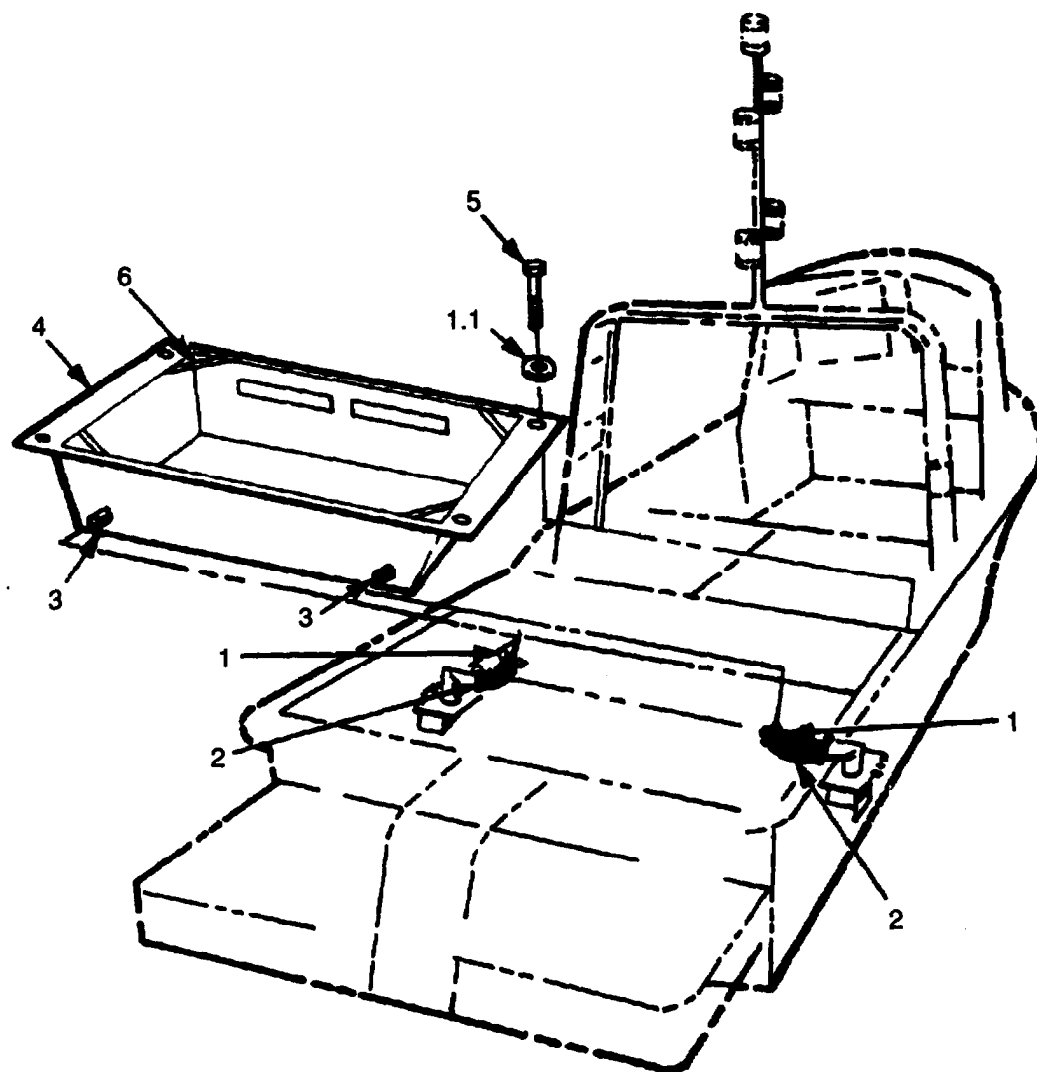

2. Using screwdriver loosen hose clamps (1) on scupper drain hose (2).
3. Pull hose (2) from drain pipes (3) located on aft cockpit (4).
4. Using wrench remove four bolts (5) and four washers (1.1) securing aft cockpit to deck.
5. Close hydrojet hatches.

NOTE

A lifting device or three personnel are required to lift aft cockpit into position.

6. Lift aft cockpit using handles (6) provided at each corner until it clears hull structure, then remove from boat.

INSTALL:

NOTE

A lifting device or three personnel are required to lift aft cockpit into position.

1. Lift aft cockpit (4) into position over drive shaft with scupper drain pipes aft and air intake ports forward.
2. Aline four holes in comers of aft cockpit with matching holes on deck.
3. Install mounting bolts (5) washers (1.1) and tighten using wrench.
4. Open hydrojet hatches (refer to paragraph 3-154).
5. Connect scupper drain hoses (2) to drain pipes (3) on aft end of cockpit.
6. Tighten drain hose clamps (1) using screwdriver.
7. Close hydrojet hatch covers.

3-28. STEERING UNIT HATCH COVER AND HINGES REPLACEMENT INSTRUCTIONS

TOOLS: Two 10 mm Box Wrenches

PARTS/MATERIALS: Steering Unit Hatch Cover
Hinges

REMOVE:

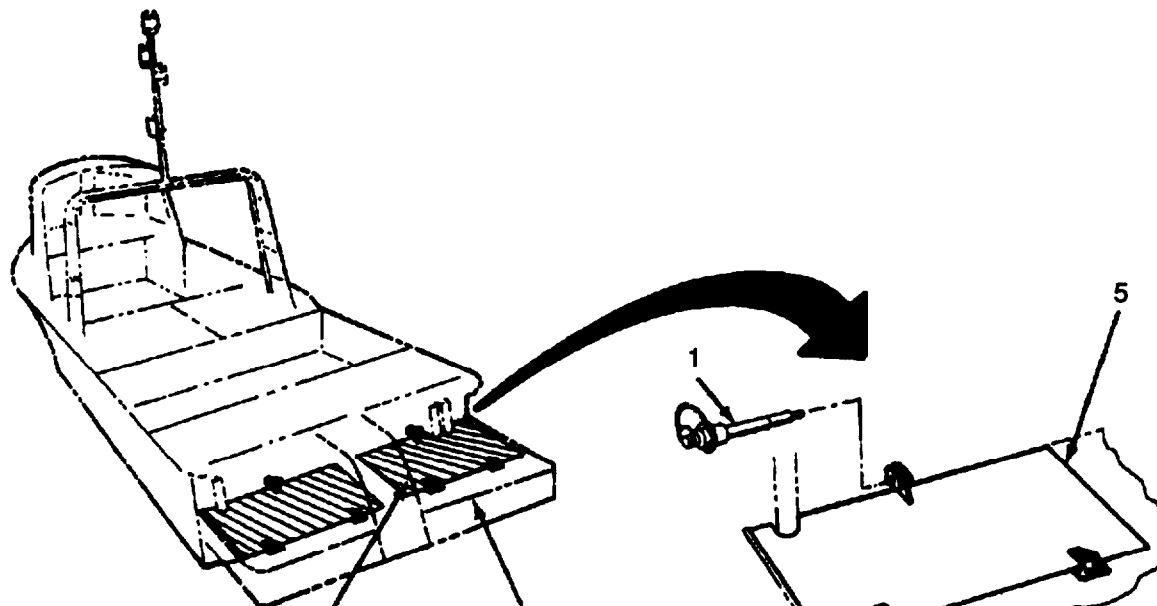

1. Depress release and remove retaining pin (1).
2. Using two wrenches remove sixteen nuts (2), thirty-two washers (3) and sixteen bolts (4) from both hinges on steering unit hatch cover (5) and diving platform (6).
3. Lift steering unit hatch cover (5) from its position.

NOTE

Nuts, bolts and washers will be reused.

INSTALL:

1. Fit new hinge plates to new cover (5) and diving platform (6). Aline bolt holes.
2. Reinstall sixteen mounting bolts (4), thirty-two washers (3) and sixteen nuts (2), tighten using two wrenches.
3. Install retaining pin (1) in latch.

3-29. SCUPPER DRAINS (FORWARD COCKPIT) SERVICING AND REPLACEMENT INSTRUCTIONS

TOOLS: One Each Flat Tip Screwdrivers, 6 inch
Scupper Removal Tool, (Item D-2, Appendix D)
(to be manufactured locally)

PARTS/MATERIALS: Ball Retainer
Ball Valve

SERVICE FORWARD COCKPIT SCUPPER DRAINS (PORT AND STARBOARD):

NOTE

Boat must be out of water on cradle or hardstand to perform this service.

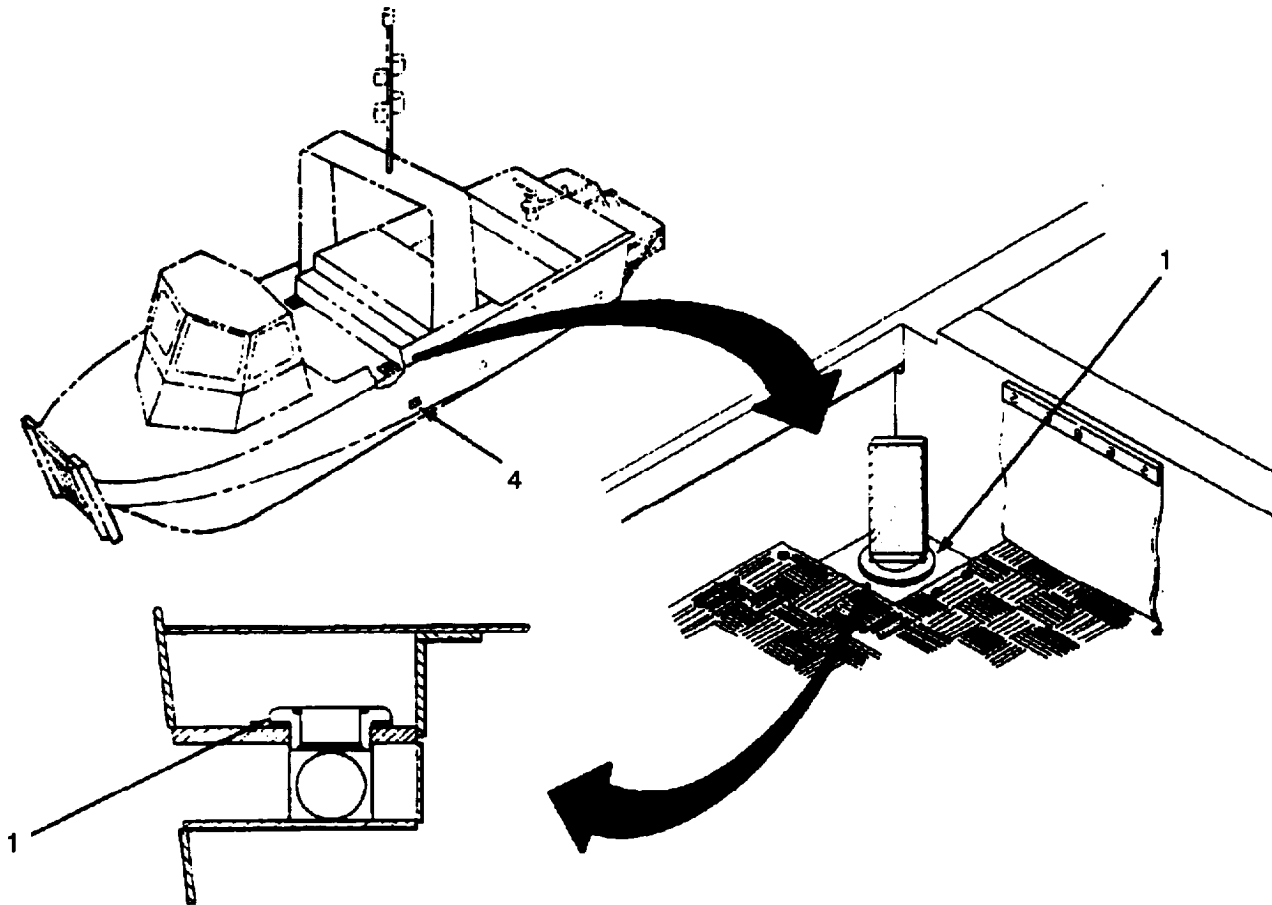

1. Remove threaded plastic scupper fitting (1) from drain by turning counterclockwise using scupper removal tool.
2. Clean fitting (1) and check for damage.

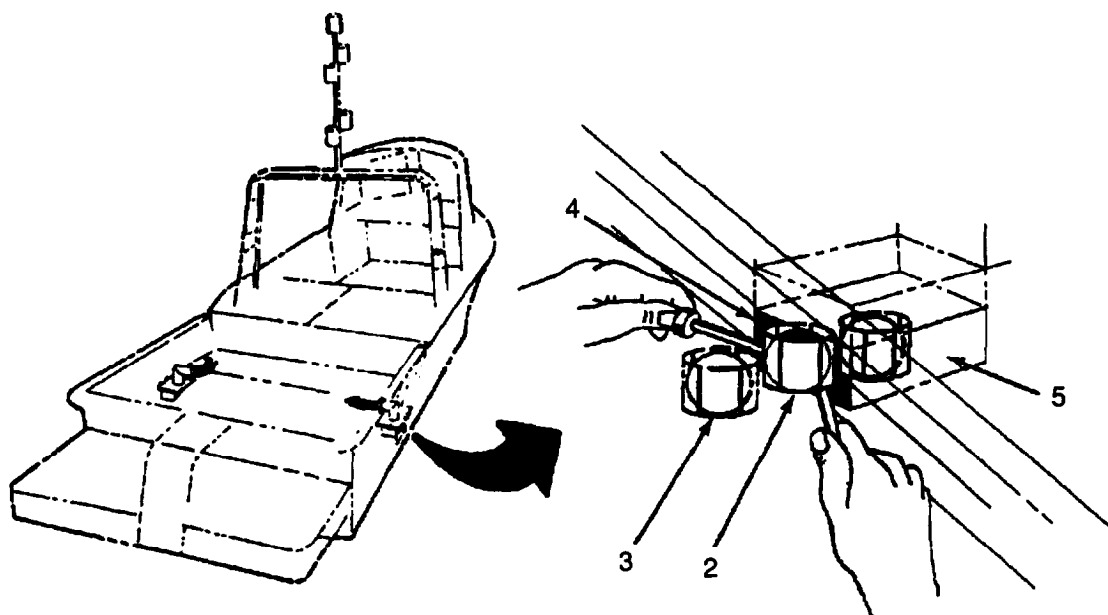

3. Using two screwdrivers withdraw retainer (2) and ball valve (3) from scupper opening in outside of boat hull (4).
4. Clean ball valve (3) and retainer (2). Check for damage and wear. Replace if necessary.
5. Remove dirt or debris from scupper body (5).
6. Reassemble ball valve (3) and retainer (2), then insert into scupper opening (4) from outside hull.
7. From inside boat align retainer (2) under scupper drain hole.

NOTE

Do not overtighten plastic fittings.

8. Install threaded scupper fitting (1) by turning clockwise.

3-30. SCUPPER DRAINS (AFT COCKPIT) SERVICING AND REPLACEMENT INSTRUCTIONS

TOOLS: Two Flat Tip Screwdrivers
Slip Joint Pliers, Angle Nose

PARTS/MATERIALS: Ball Retainer
Ball Valve
Silicone Sealant

NOTE

Boat must be out of water on hardstand or on cradle to perform this service.

REMOVE:

1. Remove aft cockpit (refer to paragraph 3-27).

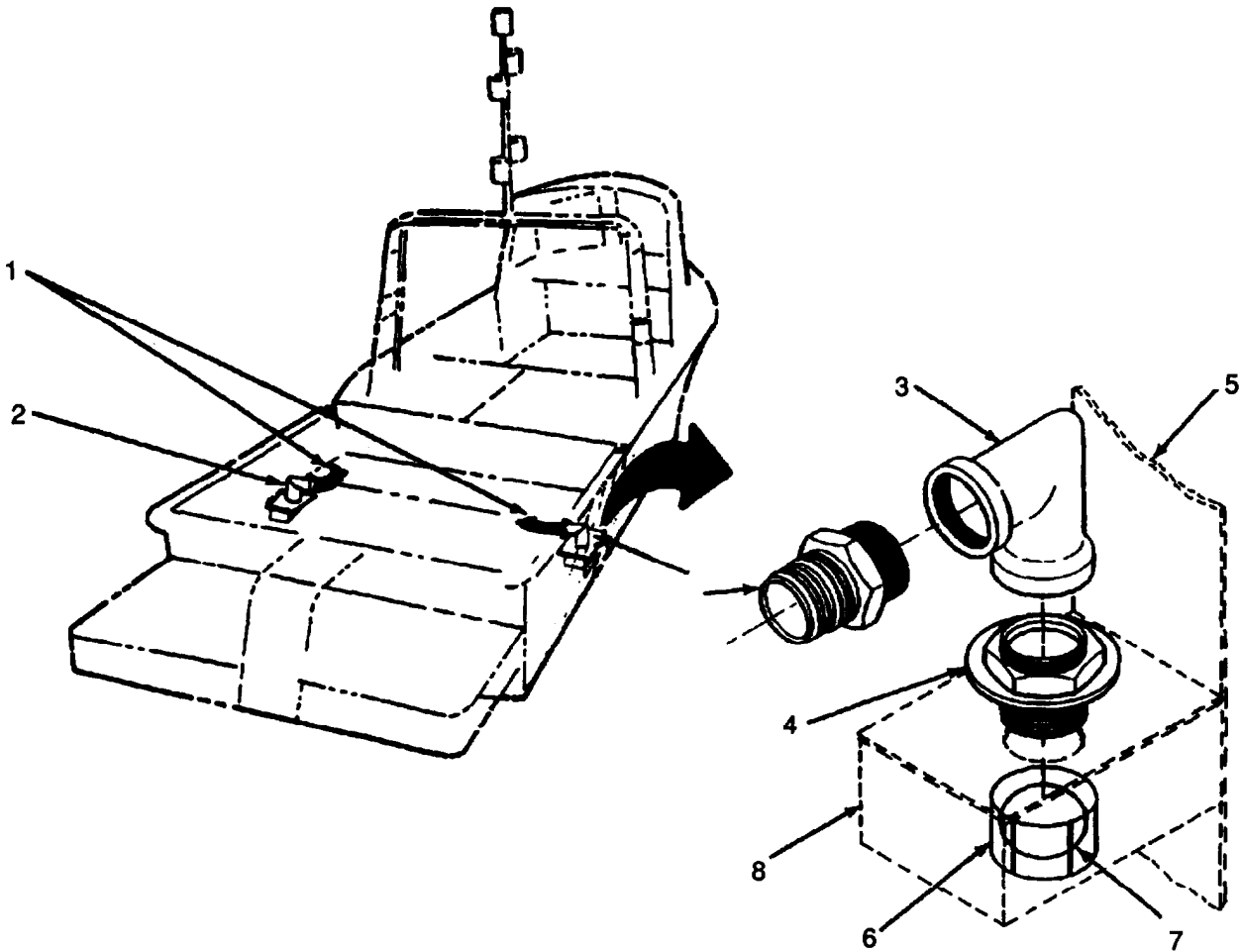

2. Remove hose (1) from hose adapter (2).
3. Using pliers, unscrew hose adapter (2) from elbow (3).
4. Using pliers, unscrew elbow (3) and hex nut with threaded pipe (4) from scupper bracket (5).
5. Check elbow (3) for damage or internal obstruction.
6. Unscrew plastic hex nut (4) from elbow (3).

7. Using two screwdrivers withdraw retainer (6) and ball valve (7) from drain opening in outside of boat hull.
8. Clean retainer (6) and ball valve (7). Check for damage or deterioration. Replace if necessary.
9. Remove any dirt or trash from scupper body (8). Clean and check threads.
10. Reassemble ball valve (7) and retainer (6), then insert into scupper opening from outside hull.
11. From inside boat align retainer (6) under scupper drain hole.
12. Coat underside of plastic hex nut (4) with silicone sealant.
13. Install plastic hex nut (4).
14. Install elbow (3) and tighten until elbow (3) points toward center line of boat.
15. Install hose adapter (2) on elbow (3).
16. Install hose (1) on hose adapter (2).
17. Install aft cockpit (refer to paragraph 3-27).

3-31. SCOOP CONTROL HEAD ASSEMBLY REPAIR INSTRUCTIONS

TOOLS: Flat Tip Screwdriver
10 mm Open End Wrench

PARTS/MATERIALS: Lever
Lever Knob
Control Head Housing

PERSONNEL REQUIRED: Two



Set master switch to "OFF".

HOUSING REPAIR:

REMOVE:

1. Open access panel under control console (refer to paragraph 3-154).

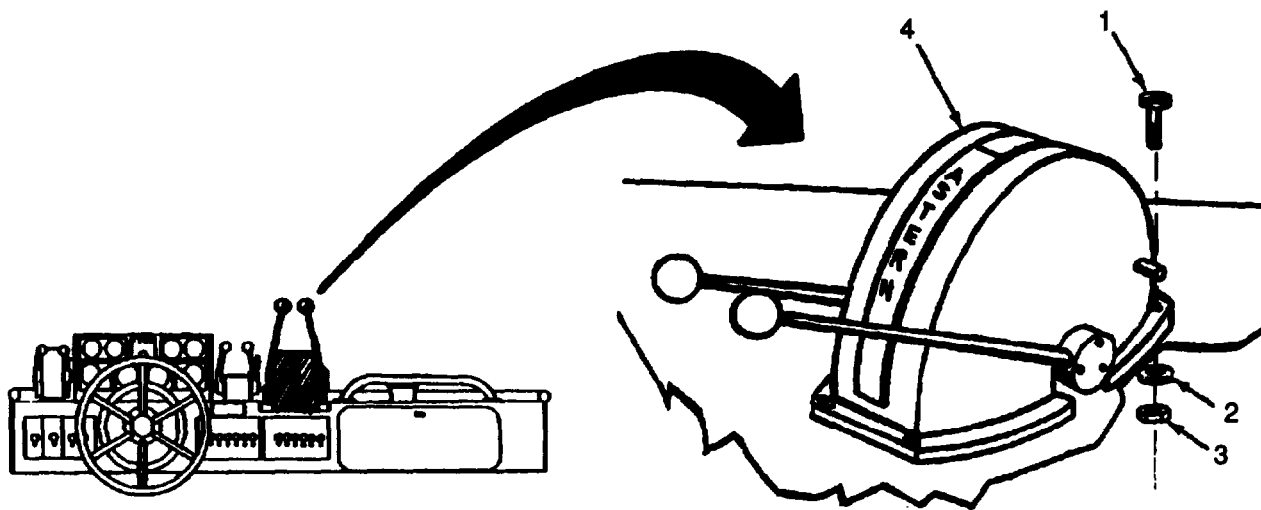

2. Using screwdriver and 10 mm open end wrench remove four screws (1), washers (2) and nuts (3) securing housing (4) to console and remove housing (4).

INSTALL:

1. Position new housing (4).
2. Using screwdriver and 10 mm open end wrench install four screws (1), washers (2) and nuts (3) securing housing (4) to console.
3. Close access panel under console.

LEVER REPAIR:

REMOVE:

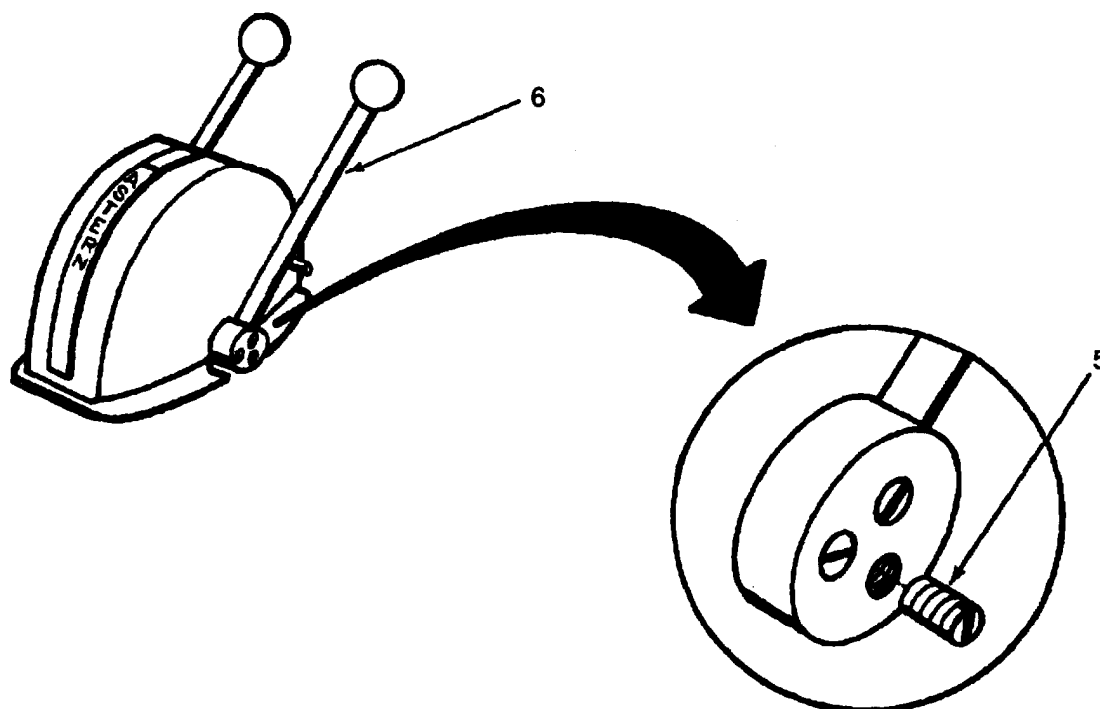

4. Using screwdriver remove three setscrews (5) at hub of lever.

5. Replace lever (6).

INSTALL:

1. Using screwdriver reinstall three setscrews (5) securing lever (6) to hub.

LEVER KNOB:

REMOVE:

1. Remove lever knob by rotating knob (7) counterclockwise.

2. Replace with new knob.

INSTALL:

1. Install lever knob (7) and secure by screwing onto lever.

3-32. SCOOP CONTROL HEAD ASSEMBLY REPLACEMENT INSTRUCTIONS

TOOLS: 13 mm Box Wrench
2 Each 3/4 inch Open End Wrench
Flat Tip Screwdriver, 4 inch
10 mm Open End Wrench
5/16 inch Open End Wrench

PARTS/MATERIALS: Control Head Assembly

PERSONNEL REWIRED: Two

REMOVE:



Set master switch to "OFF". Shock or burns to personnel may result

NOTE

To adjust the scoop control cables, it is necessary to free the cables at their rotary control assemblies. These are located aft, directly inboard of the scoops.

1. Open access panel under control console (refer to paragraph 3-154).
2. Open and secure hydrojet hatch (refer to paragraph 3-154).

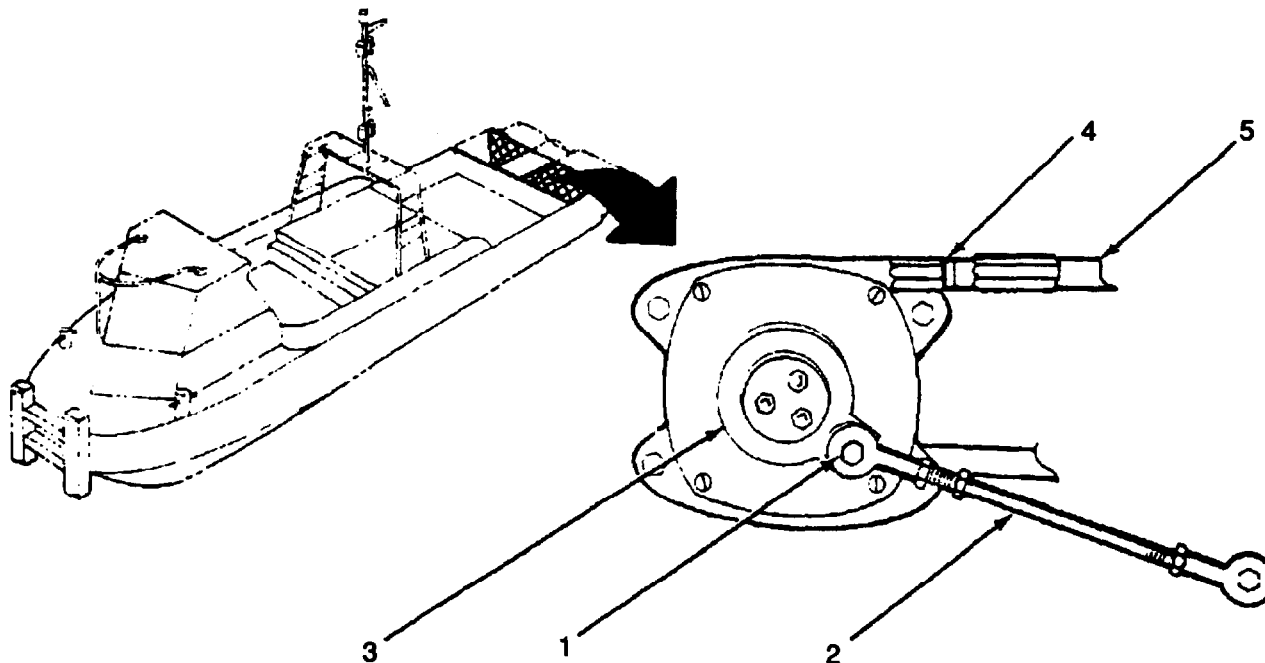

3. Using 13 mm box wrench remove self-locking nut (1) securing rotary control rod (2).
4. Slide control rod (2) off drain (3).
5. Using 3/4 inch open end wrench remove split coupling (4) securing cable (5) to rotary control.
6. Turn drain (3) clockwise until end of cable is free.

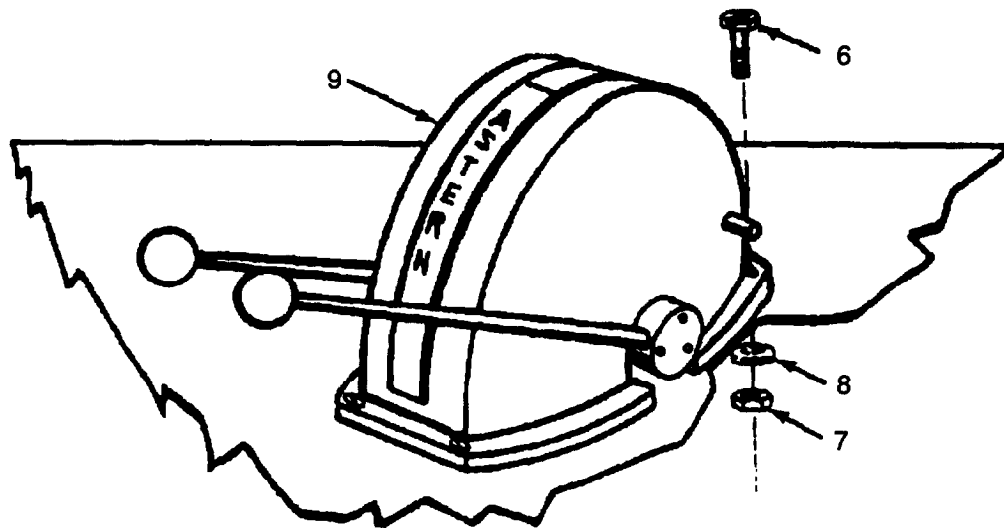

7. Using screwdriver and 5/16 in. open end wrench remove nuts (7), washers (8) and bolts (6) securing scoop control head housing to console.
8. Remove scoop control head housing (9).

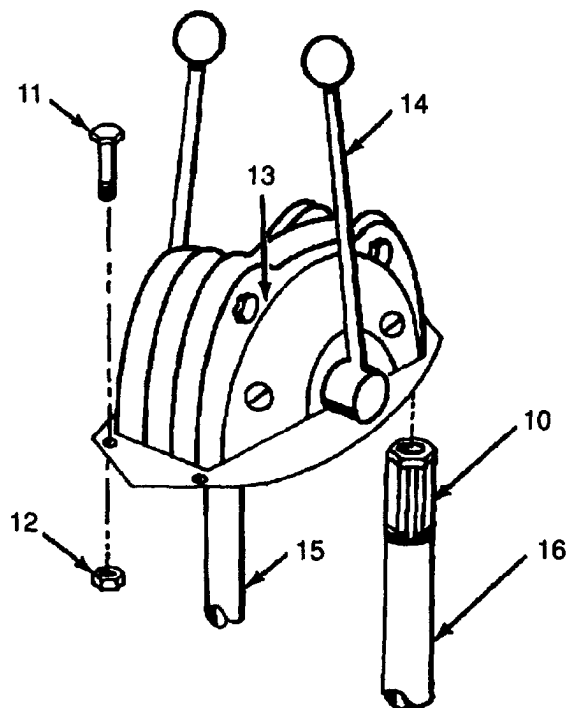

9. Using 3/4 inch open end wrench remove split couplings (10) securing cables.
10. Using screwdriver and 10 mm open end wrench remove nuts (12) and four bolts (11) securing scoop control head (13) to console.
11. Pull scoop control head (13) out of console.
12. Rotate levers (14) forward towards console until ends of cables are free.
13. Replace scoop control head (13) assembly.

INSTALL:

1. Place scoop control head levers (14) in neutral position.
2. Insert cable (16) into cable fitting and rotate lever (14) one complete revolution away from console. With lever again in neutral position, approximately two inches of cable will be visible in spent cable tube (IS).
3. Using 3/4 inch open end wrench install split couplings (10) securing cables.
4. Place scoop control head (13) in console.
5. Using screwdriver and 10 mm open end wrench install four screws (11) and nuts (12) securing scoop control head (13) to console.

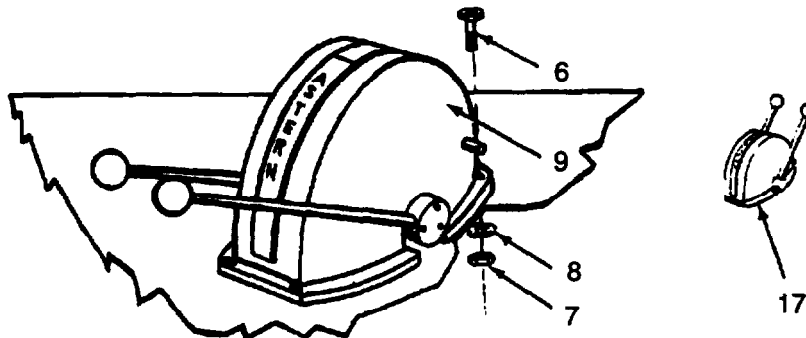

6. Place scoop control housing (9) over scoop control head.
7. Using screwdriver and 8 mm open end wrench install four screws (6), washers (8) and nuts (7) securing scoop control housing (9) to console.
8. Place scoop control levers (17) in FULL FORWARD position.
9. Close access panel (refer to paragraph 3-154).

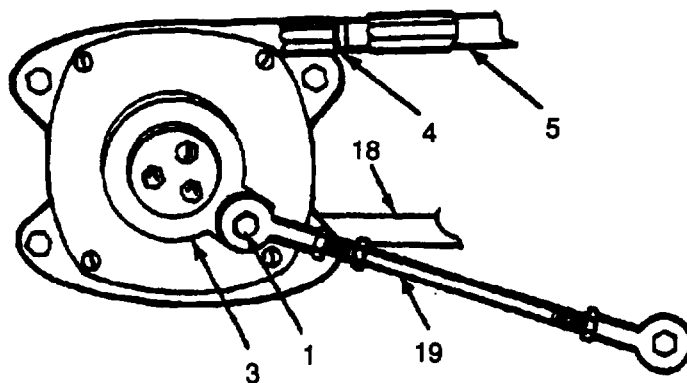

10. Turn crank (3) to nine o'clock position.
11. Insert cable end (5) into cable fitting and turn crank (3) to take up slack of cable. Several inches of cable will be visible in spent cable tube (18).

NOTE

Control rod (19) may be adjusted to slide onto crank.

12. Using 18 mm open end wrench install split coupling (4) to secure cable.
13. Place scoop in FULL FORWARD position and slide control rod (19) onto crank Using 13 mm box wrench install self-locking nut (1).
14. Check scoop linkage adjustment (refer to paragraph 3-35).
15. Close hydrojet hatches (refer to paragraph 3-154).

3-33. ENGINE OR TRANSMISSION CONTROL HEAD ASSEMBLY REPAIR INSTRUCTIONS

TOOLS: 3/8 inch Open End Wrench
Flat Tip Screwdriver, 4 inch
Long Nose Pliers
5/32 inch Hex Key Wrench (Allen)

PARTS/MATERIALS: Control Lever
Control Knob

PERSONNEL REQUIRED: Two

LEVER REPAIR:

REMOVE:

1. Remove control head (refer to paragraph 3-34).

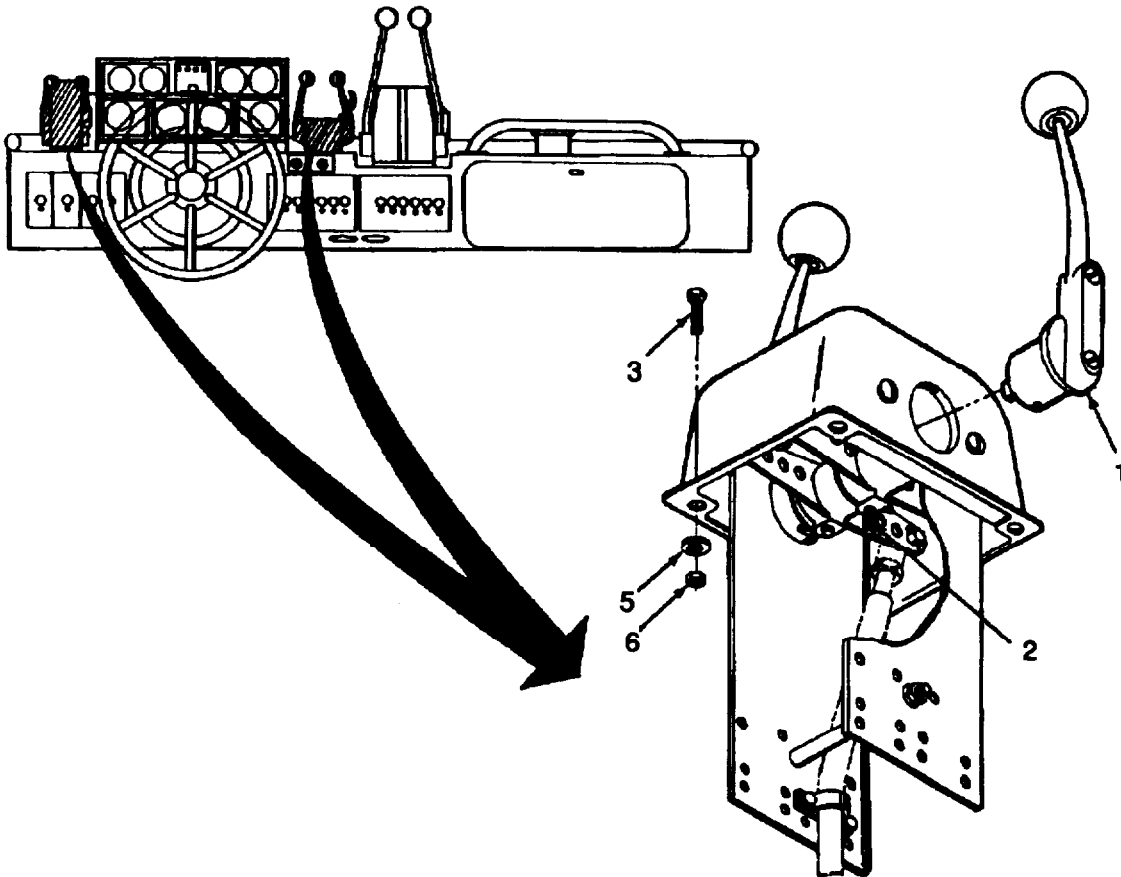

2. Slide lever (1) off hub pin.

INSTALL:

1. Replace lever.
2. Using Allen wrench tighten socket head screws (2).
3. Replace control head into console (refer to paragraph 3-34).

LEVER KNOB REPAIR:

REMOVE:

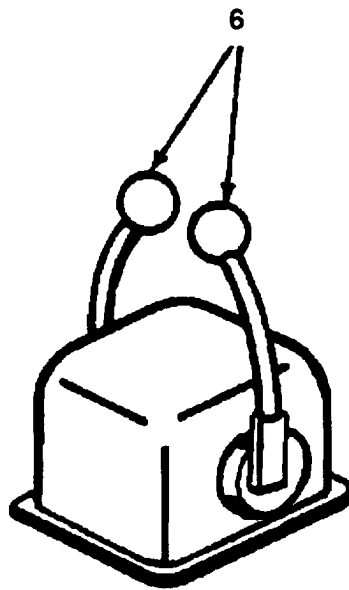

1. Rotate lever knob (6) counterclockwise.

INSTALL:

1. Rotate new lever knob (6) clockwise to tighten.

3-34. ENGINE OR TRANSMISSION CONTROL HEAD ASSEMBLY REPLACEMENT INSTRUCTIONS

TOOLS: 3/8 inch Open End Wrench
Flat Tip Screwdriver, 4 inch
Long Nose Pliers
5/32 inch Hex Key Wrench (Allen)

PARTS/MATERIALS: Control Head Assembly
Cotter Pins

PERSONNEL REQUIRED: Two

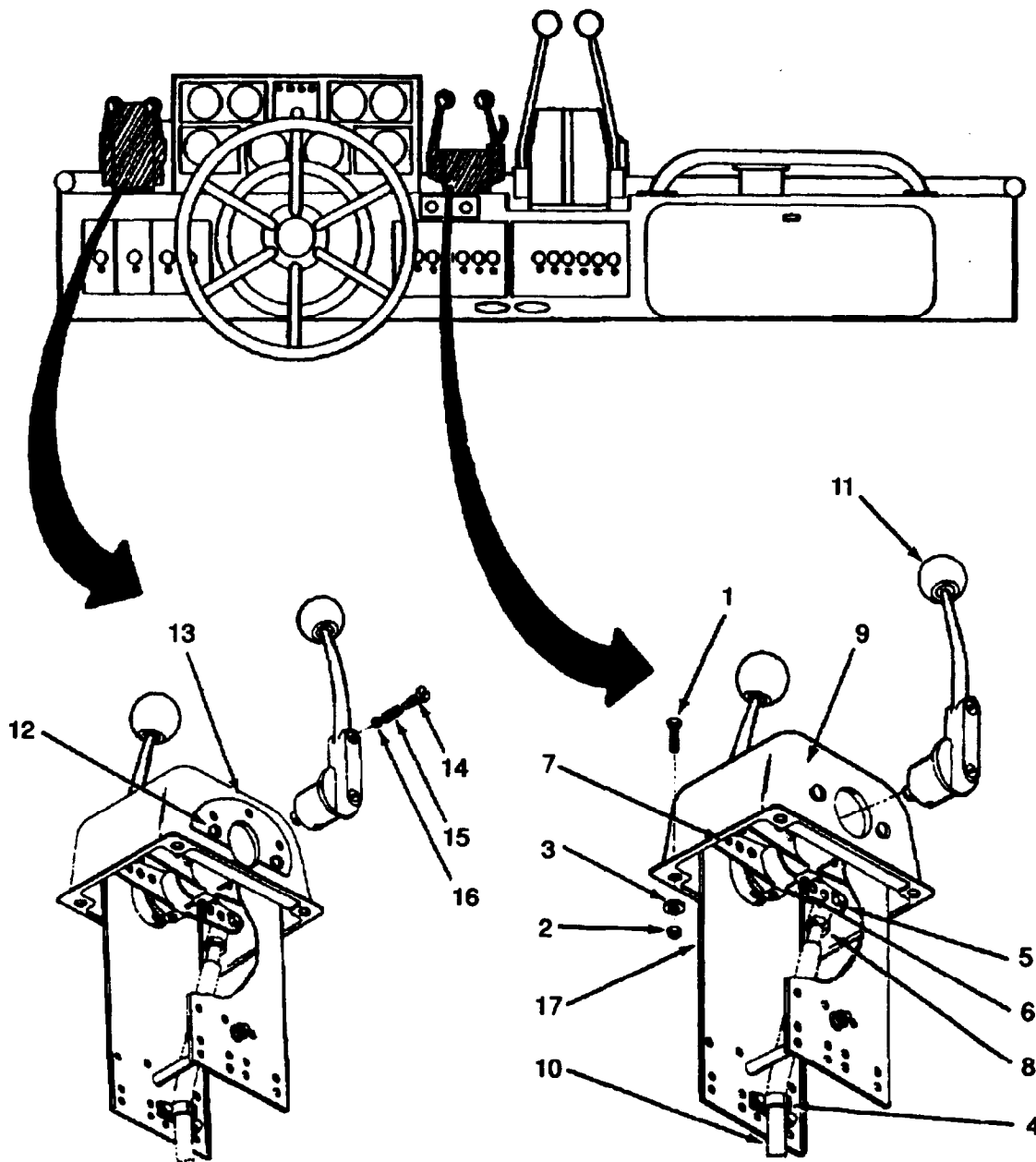

CAUTION

The cables should NOT be bent sharply in any direction. Severe cable damage may result.

NOTE

Transmission control head assembly is identical to engine control head assembly except for detent plate.

REMOVE:

1. Open access panel under control console (refer to paragraph 3-154).
2. Using screwdriver and 3/8 inch open end wrench remove four nuts (2), washers (3) and bolts (1) securing control head to console.
3. Using 3/8 inch open end wrench remove cable dampers (4) from control head side plates (17).
4. Pull control head out of console as far as attached cables will allow.
5. Using pliers remove cotter pins (5) securing cable pivots (8).
6. Using Allen wrench loosen socket head screw (6).
7. Move linkage plates (7) as required to allow clearance for cable pivots.
8. Remove cable pivots (8).
9. Lift engine control head assembly (9) out of console.
10. Slide control handles (11) off shaft.
11. For transmission control head assembly, using screwdriver remove screws (12) holding detent plate (13).
12. Remove screw (14), spring (15) and ball (16).

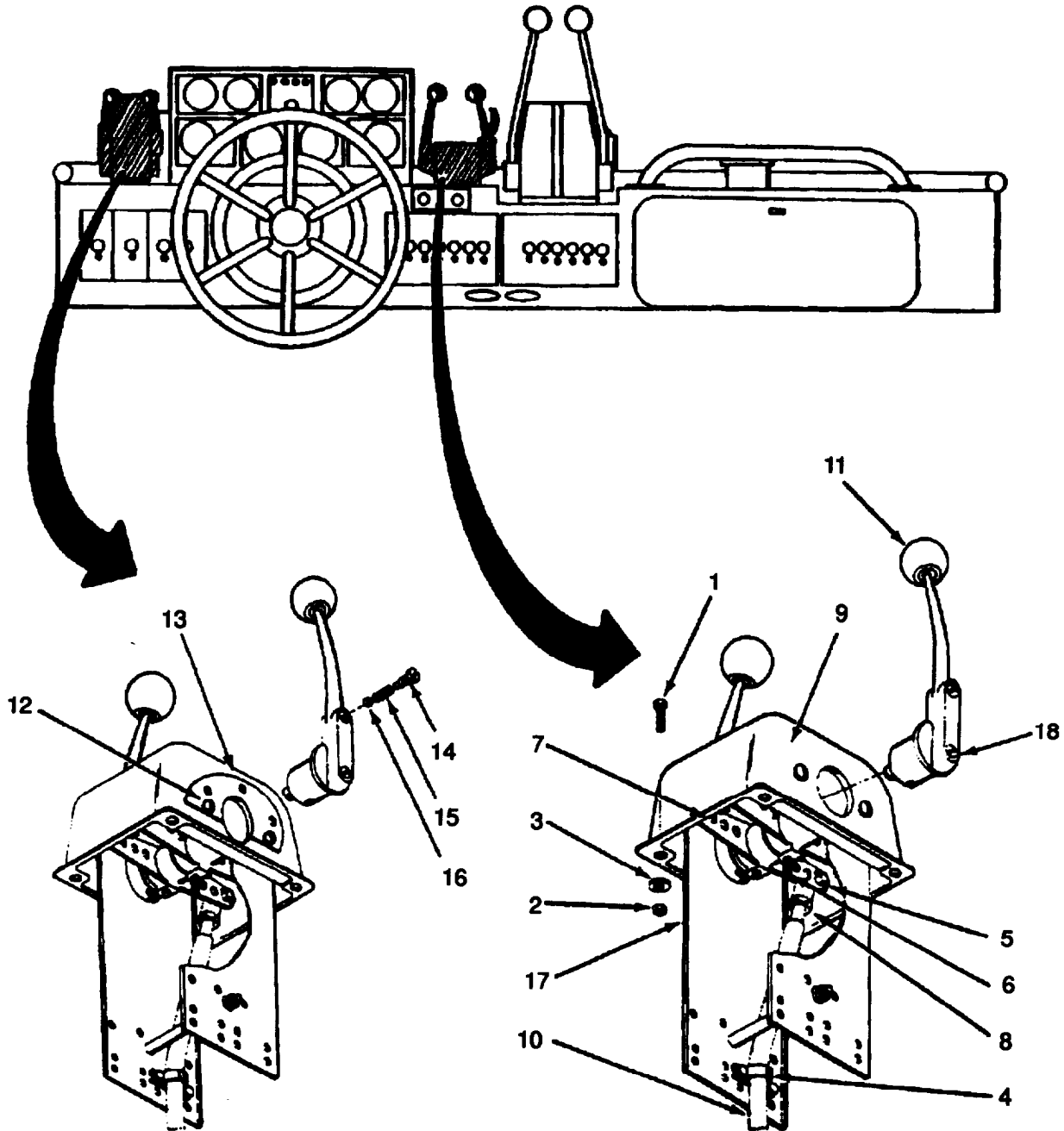

INSTALL:

1. On new assembly loosen socket head screw (6) using Allen wrench.
2. Slide control lever off hub pin.
3. For transmission control head assembly, install detent plate (13) and secure with screws (12).
Slide control lever back on hub pin.
- 4.
5. Install ball (16), spring (15) and screw (14) on control handle.
6. Using flat tip right angle screw driver tighten screw (18) for friction adjustment.

NOTE

Procedure applies to each control handle.

7. Move linkage plates (7) as required to allow clearance for cable pivots (8).

NOTE

Use outer linkage holes for 2-3/4 inch travel.

8. Insert cable pivots (8) in linkage plates (7).
9. Using Allen wrench tighten socket head setscrews (6).
10. Using pliers place cotter pins (5) to secure cable pivots (8).
11. Flare ends of cotter pins (5).
12. Place control head into console.
13. Using 9 mm open end wrench secure cables (10) to control head side plates (17) with cable dampers (4).
14. Using screwdriver and 3/8 inch open end wrench install four bolts (1), washers (3) and nuts (2) securing control head to console.
15. Close access panel under console (refer to paragraph 3-154).

3-35. LINKAGE SCOOP CONTROL ASSEMBLY ADJUSTMENT INSTRUCTIONS

TOOLS: 17 mm Open End Wrench
3/16 inch Hex Key Wrench (Allen)

NOTE

Boat must be out of water on cradle or hardstand to perform this service.

ADJUST:

1. Open and secure hydrojet hatches (refer to paragraph 3-154).
2. Open steering unit hatches.

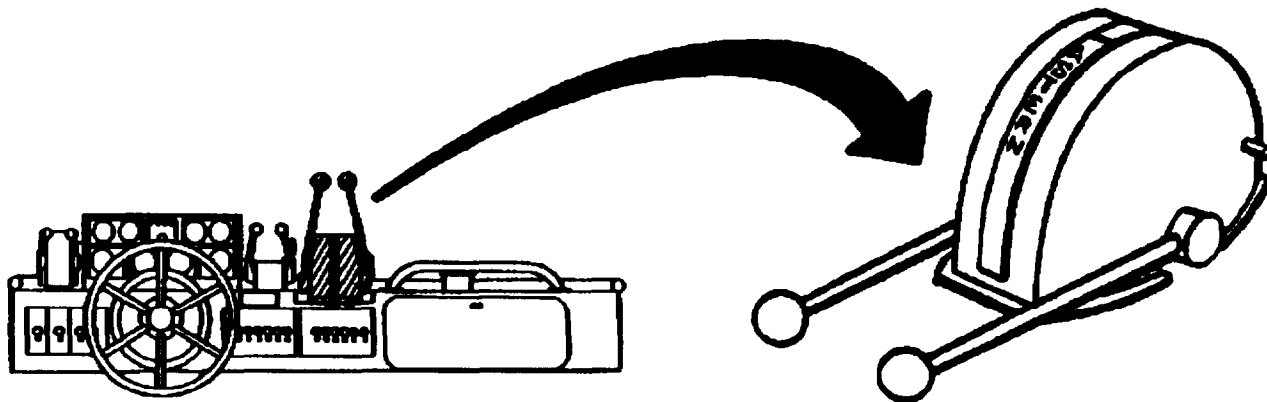

3. Place scoop controls in FULL ASTERN position.

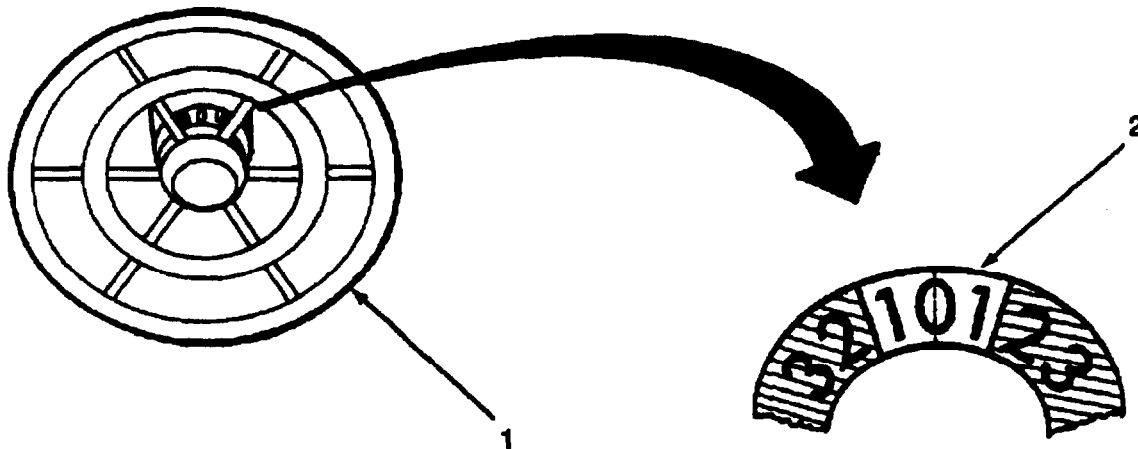

4. Turn steering wheel (1) until scoop position indicator (2) is on zero.

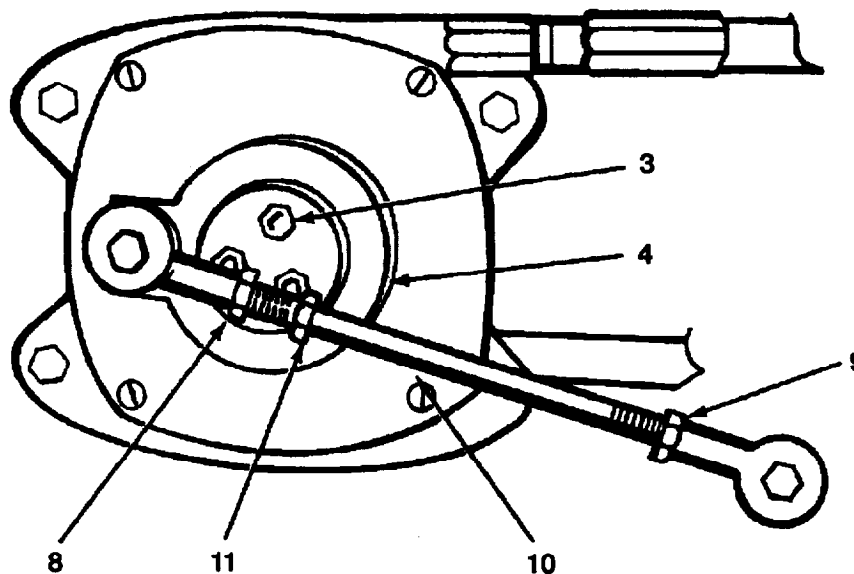

5. Using Allen wrench loosen three socket head screws (3), unlocking crank (4).
6. Move scoop (5) by hand until pivot nut (6) comes in contact with cast stop (7).

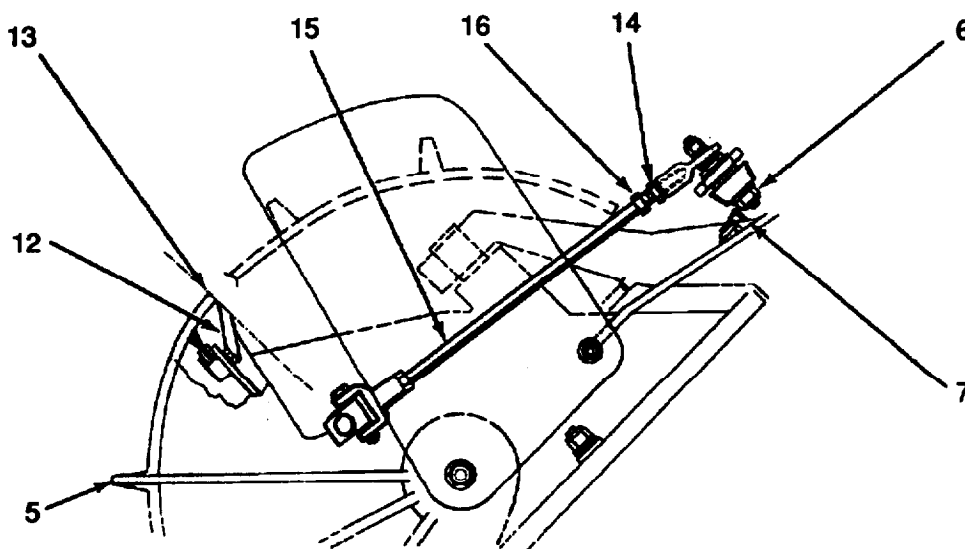

7. Using wrench loosen locking nuts (8 and 9) on rotary control rod (10) located inboard of transom).
8. Using wrench on fixed nut (11) turn control rod (10) to lengthen or shorten rod as required until crank (4) is approximately horizontal in 9 o'clock position.
9. Using Allen wrench tighten three socket head screws (3), locking crank (4).

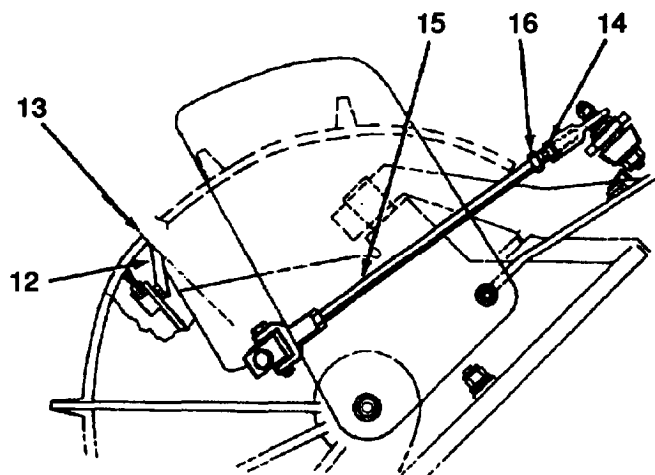

10. Check that scoop alignment indicator (12) is lined up with top of jet outlet (13).
11. Using wrench loosen locking nuts (14) on scoop control rods (15) (located outboard above hydrojets).
12. Using wrench turn fixed nut (16) to lengthen or shorten rods until scoops are alined with scoop alinement indicator (12).

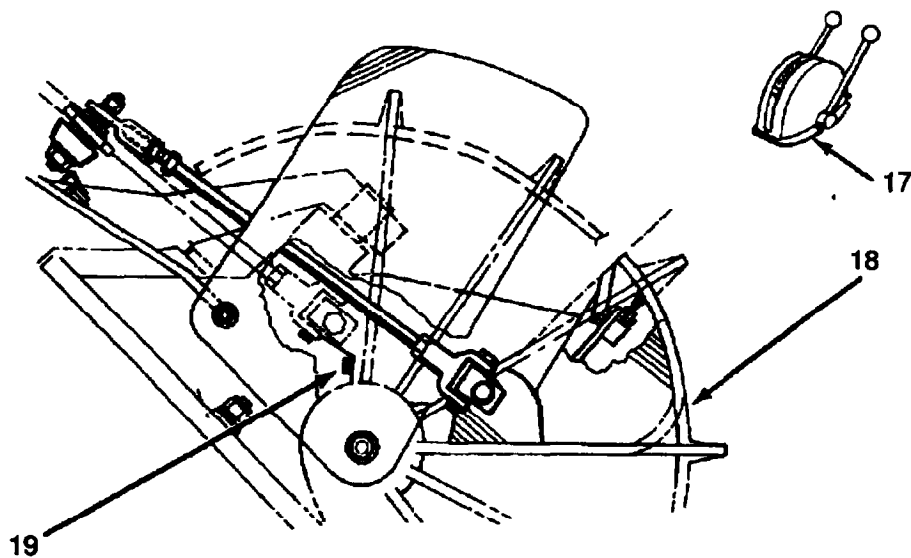

13. Place scoop control (17) in full AHEAD position.
14. Check that scoop (18) is firmly against cast stop (19) on rotating outlet.
15. Close hydrojet hatches.
16. Close steering unit hatches.

3-36. SCOOP CONTROL CABLE REPLACEMENT INSTRUCTIONS (PORT AND STARBOARD)

TOOLS: 1/2 inch Box Wrench
3/4 inch Open End Wrench
Flat Tip Screwdriver
10 mm Open End Wrench

PARTS/MATERIALS: Bucket Control Cable
Two Feet, Solid Wire (Recommend 18 Gage)

NOTE

Port bucket control cable is 27' 10" in length. Starboard bucket control cable is 31'5" in length.

PERSONNEL REQUIRED: Three



Set master switch to "OFF". Shock and bums may result.

REMOVE:

1. Open and secure hydrojet hatches (refer to paragraph 3-154).

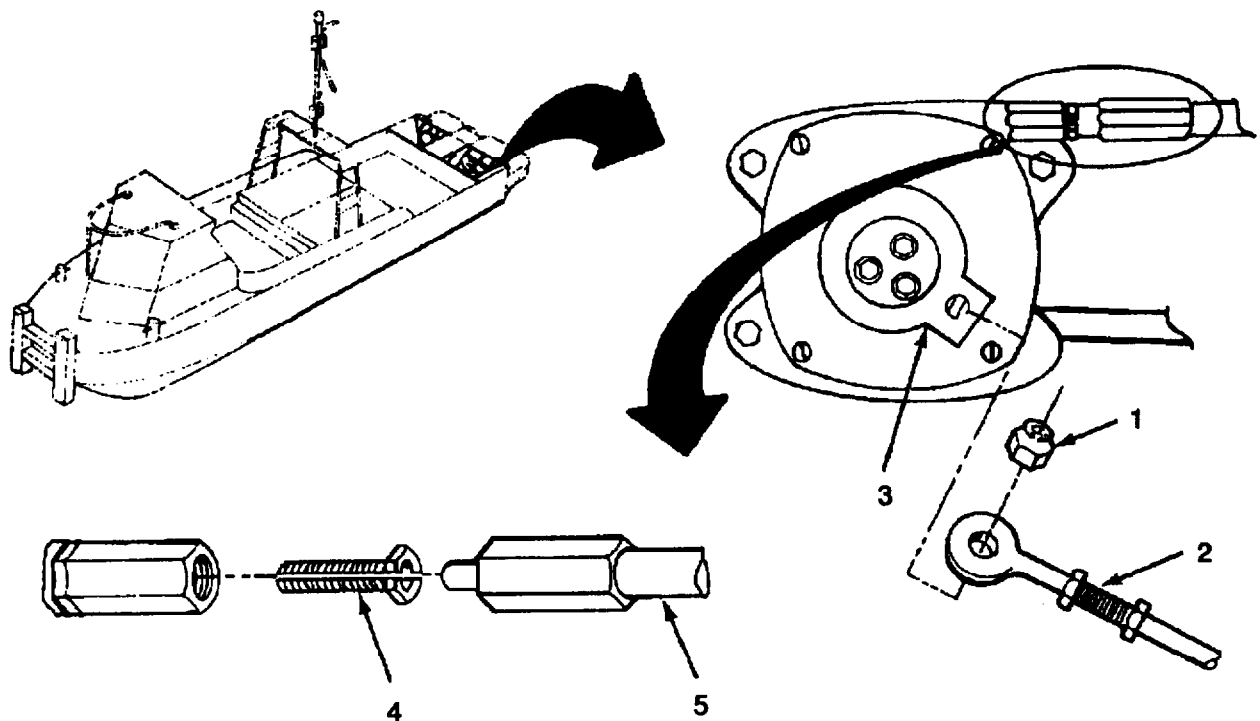

2. Using 1/2 inch box wrench remove self-locking nut (1) securing rotary control rod (2).
3. Slide control rod (2) off crank (3).

4. Using 3/4 inch open end wrench remove split coupling (4) securing cable (5).
5. Turn crank (3) clockwise until end of cable (5) is free.
6. Open access panel under control tie (refer to paragraph 3-154).

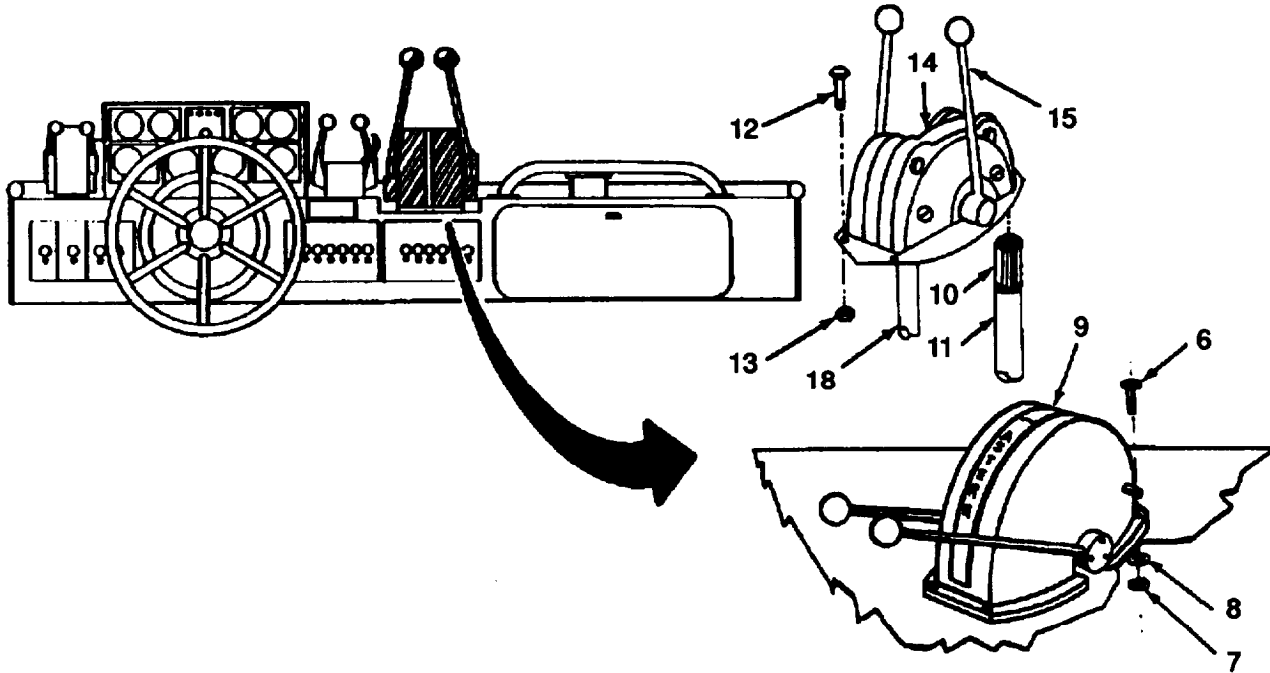

7. Using screwdriver and 10 mm open end wrench remove four screws (6), nuts (7) and washers (8) securing scoop control housing (9) to console.
8. Remove scoop control housing (9).
9. Using 3/4 inch open end wrench remove split couplings (10) securing cables (11) to control head (14) behind console.
10. Using screwdriver and 10 mm open end wrench remove four screws (12) and nuts (13) securing scoop control head (14) to console.
11. Pull scoop control head (14) from console.
12. Rotate levers (15) forward until cable ends (11) are free.
13. Remove aft cockpit (refer to paragraph 3-27).
14. Remove portside buoyancy flotation material (refer to paragraph 3-152).

INSTALL:

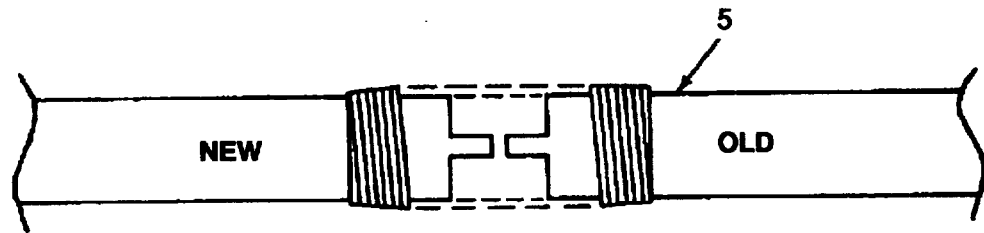

1. Butt end of new cable to end of old cable (5) at stem. Wire cable ends together securely using solid wire.
2. Using three people to guide wire, pull new cable into position at console.
3. Unwire new cable from old cable (5).
4. Place scoop control head levers in neutral position.

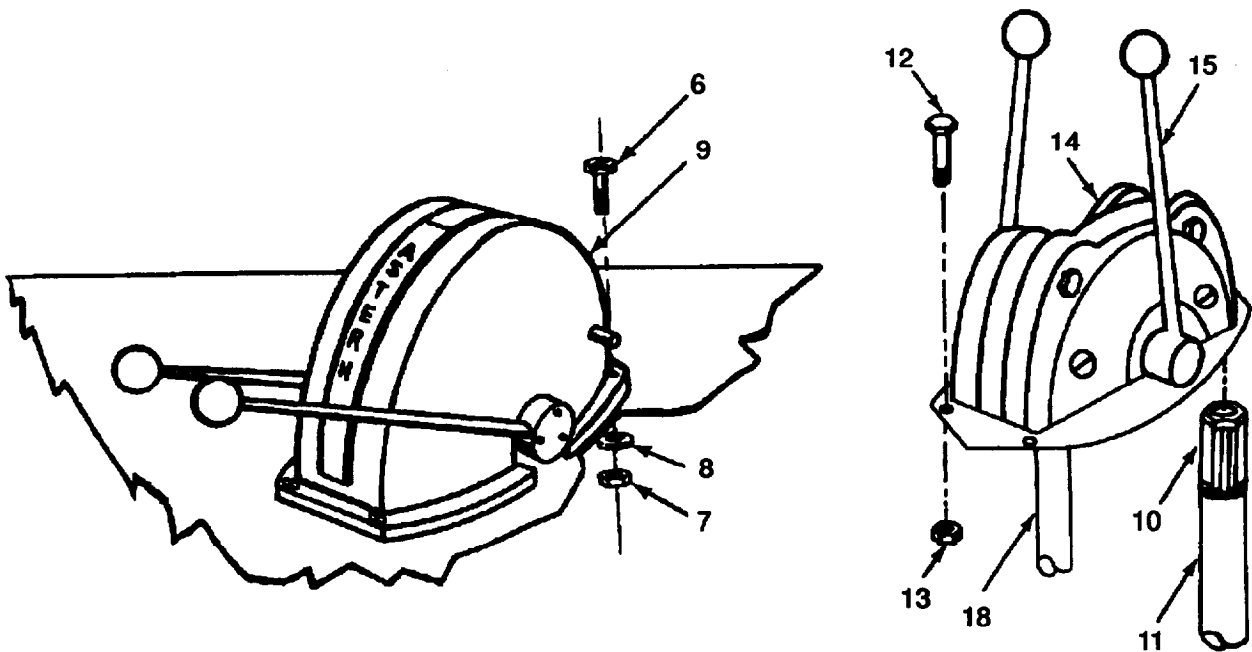

5. Insert cable (11) into cable fitting and rotate lever (15) backward one complete revolution. With lever again in neutral position, approximately two inches of cable will be visible in spent cable tube (18).
6. Using 3/4 inch open end wrench install split couplings (10) to secure cables (11) to control head (14).

7. Place scoop control head (14) in console.
8. Using screwdriver and 10 mm open end wrench install four screws (12) and nuts (13) securing scoop control head (14) to console.
9. Place scoop control housing (9) over scoop control head (14).
10. Using screwdriver and 8 mm open end wrench install four screws (6), washers (8) and nuts (7) securing scoop control housing (9) to console.

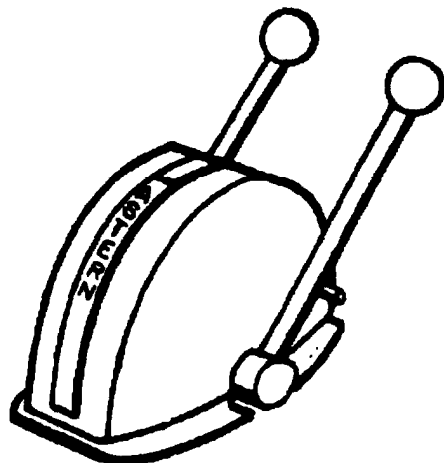

11. Place scoop control levers in FULL FORWARD position.

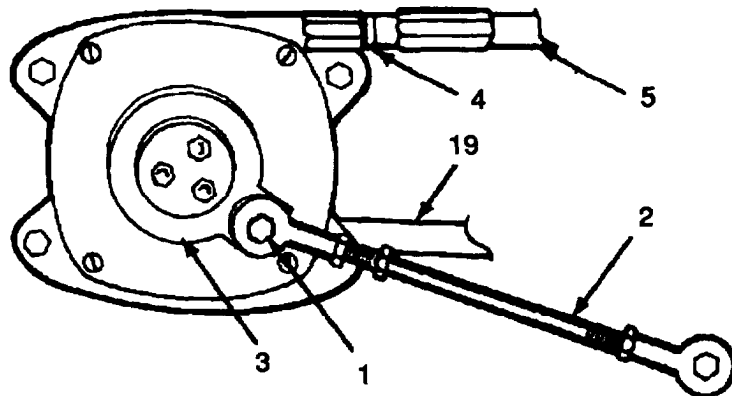

12. Turn crank (3) to nine o'clock
13. Insert cable (5) into cable fitting and turn crank (3) to take up slack of cable. Several inches of cable will be visible in spent cable tube (19).

14. Using 3/4 inch open end wrench install split coupling (4) to secure cable (5).

NOTE

Control rod may be adjusted to slide onto crank

15. Place scoops in FULL FORWARD position and slide control rod (2) onto crank (3). Using 1/2 inch box wrench reinstall self-locking nut (1).
16. Reinstall portside buoyancy flotation material (refer to paragraph 3-152).
17. Reinstall aft cockpit (refer to paragraph 3-27).
18. Check scoop linkage adjustment (refer to paragraph 3-35).
19. Close hydrojet hatches.

3-37. CONTROL CABLE AND LINKAGE ADJUSTMENT INSTRUCTIONS (TRANSMISSION AND ENGINE)

TOOLS: Long Nose pliers

7/16 inch Open End Wrench

PARTS/MATERIALS: Cotter Pins

REMOVE:

1. Open access panel under control console (refer to paragraph 3-154).
2. Remove control head assembly (refer to paragraph 3-34).

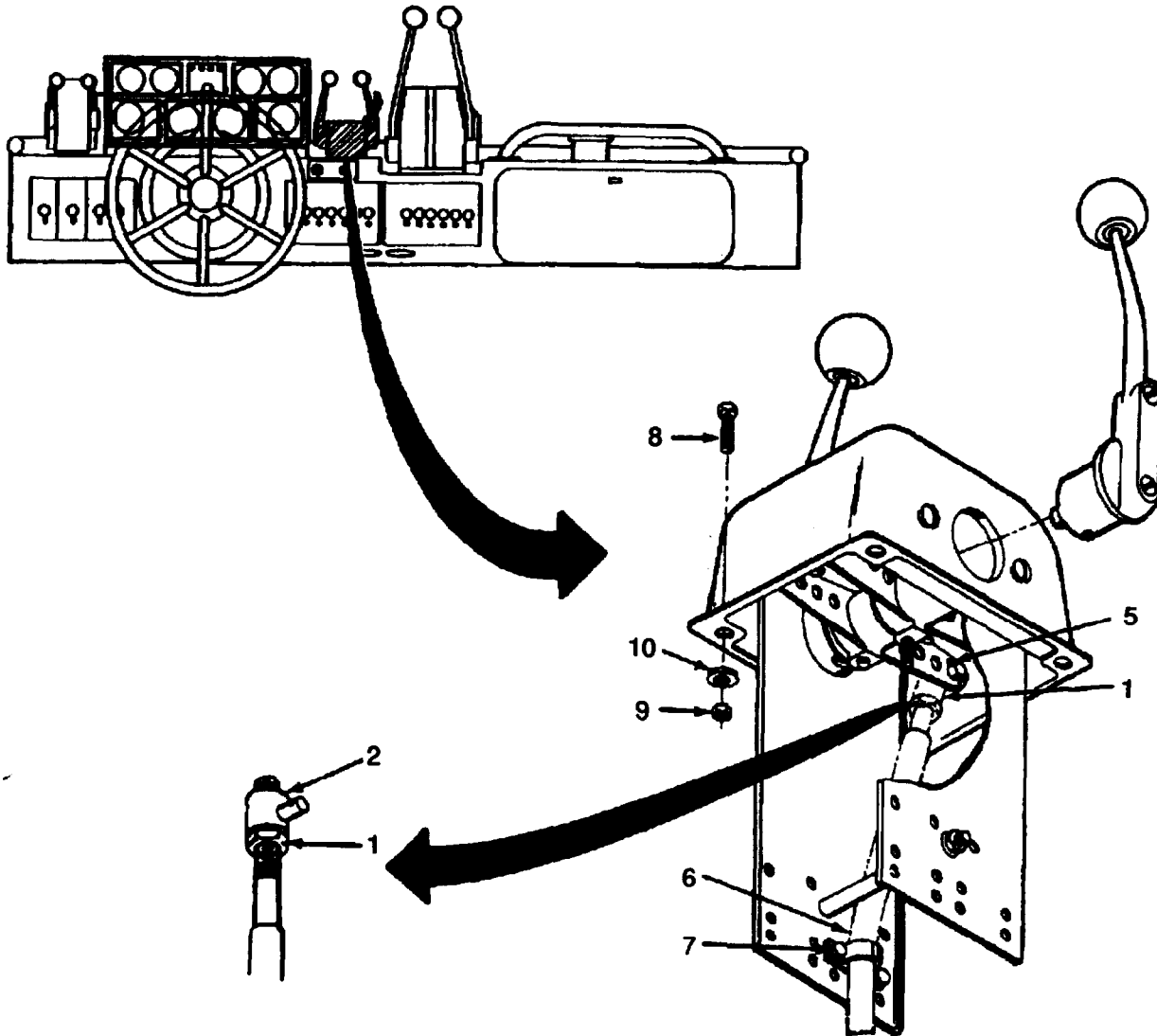

ADJUST CONTROL LINKAGES AT CONSOLE:

1. Using 7/16 inch open end wrench loosen nut (1) beneath cable pivots (2).
2. Rotate cable pivot (2) to adjust cable length.
3. Reinstall control head into console (refer to paragraph 3-34, steps 6 thru 13).
4. Close access control panel (refer to paragraph 3-154).

ADJUST CONTROL LINKAGES AT TRANSMISSION AND INJECTOR PUMP:

1. Open and secure engine hatches (refer to paragraph 3-154).

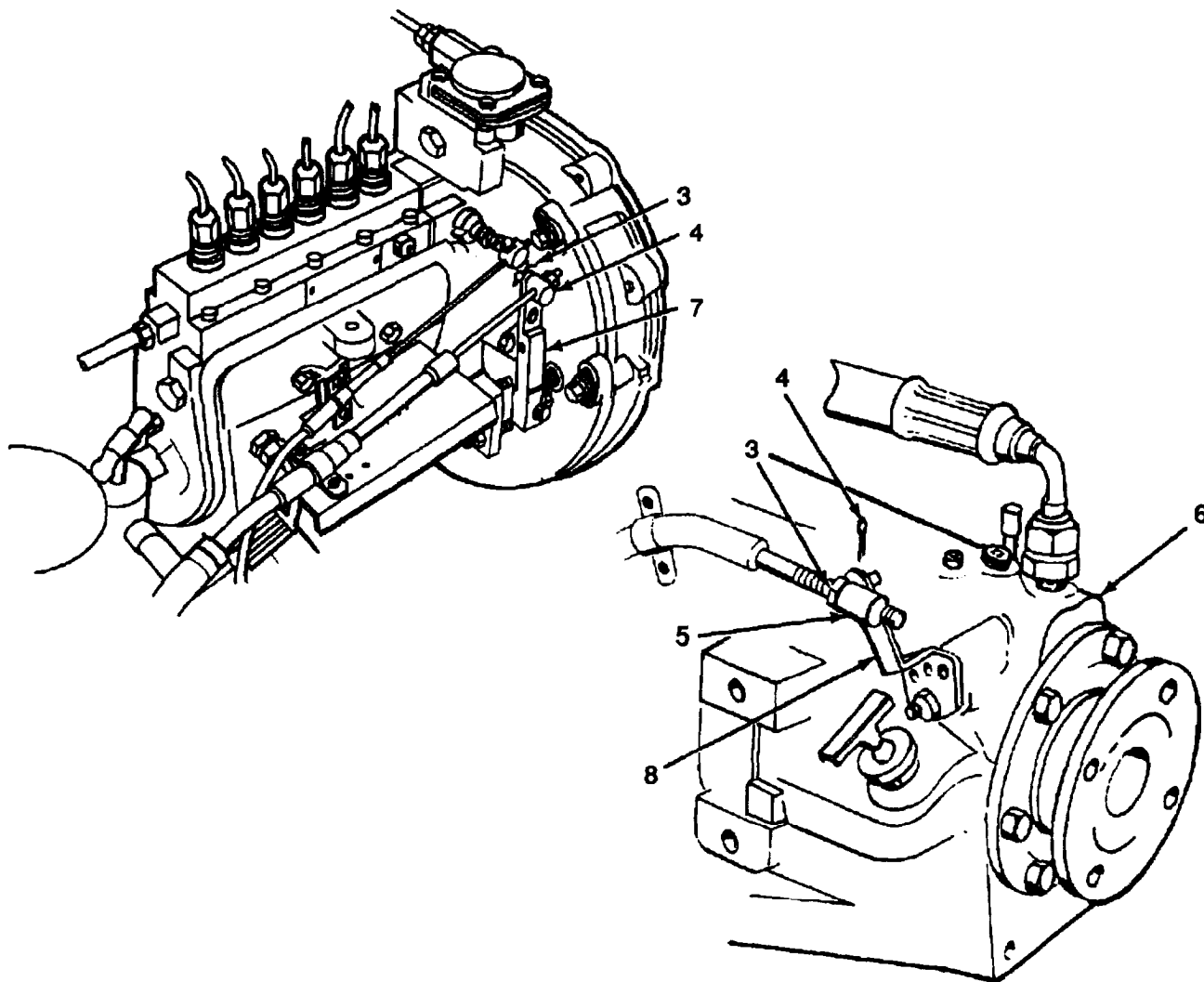

2. Using 7/16 inch wrench loosen nut (3).
3. Using pliers remove cotter pin (4) from cable pivot (5) at transmission (6) or injector pump (7).
4. Remove cable pivot from injector pump or transmission control lever (8).
5. Place transmission selector handle and transmission control lever in neutral position.
6. Place throttle control lever full forward.
7. Rotate cable pivot (5) to adjust cable length.
8. Reinstall cable pivot (5) on injector pump control lever (7) or transmission control lever.
9. Using pliers install new cotter pin (4).
10. flare end of cotter pin (4).
11. Using 7/16 inch wrench tighten nut (3).
12. Close engine hatches.

3-38. TRANSMISSION CABLE REPLACEMENT INSTRUCTIONS

TOOLS: Flat Tip Screwdriver, 4 inch
Long Nose Pliers
5/16 in. Open End Wrench

PARTS/MATERIALS: Two Feet, Solid Wire (Recommend 18 Gauge)
Morse Teleflex Transmission Cable
Cotter pin

PERSONNEL REQUIRED: Two

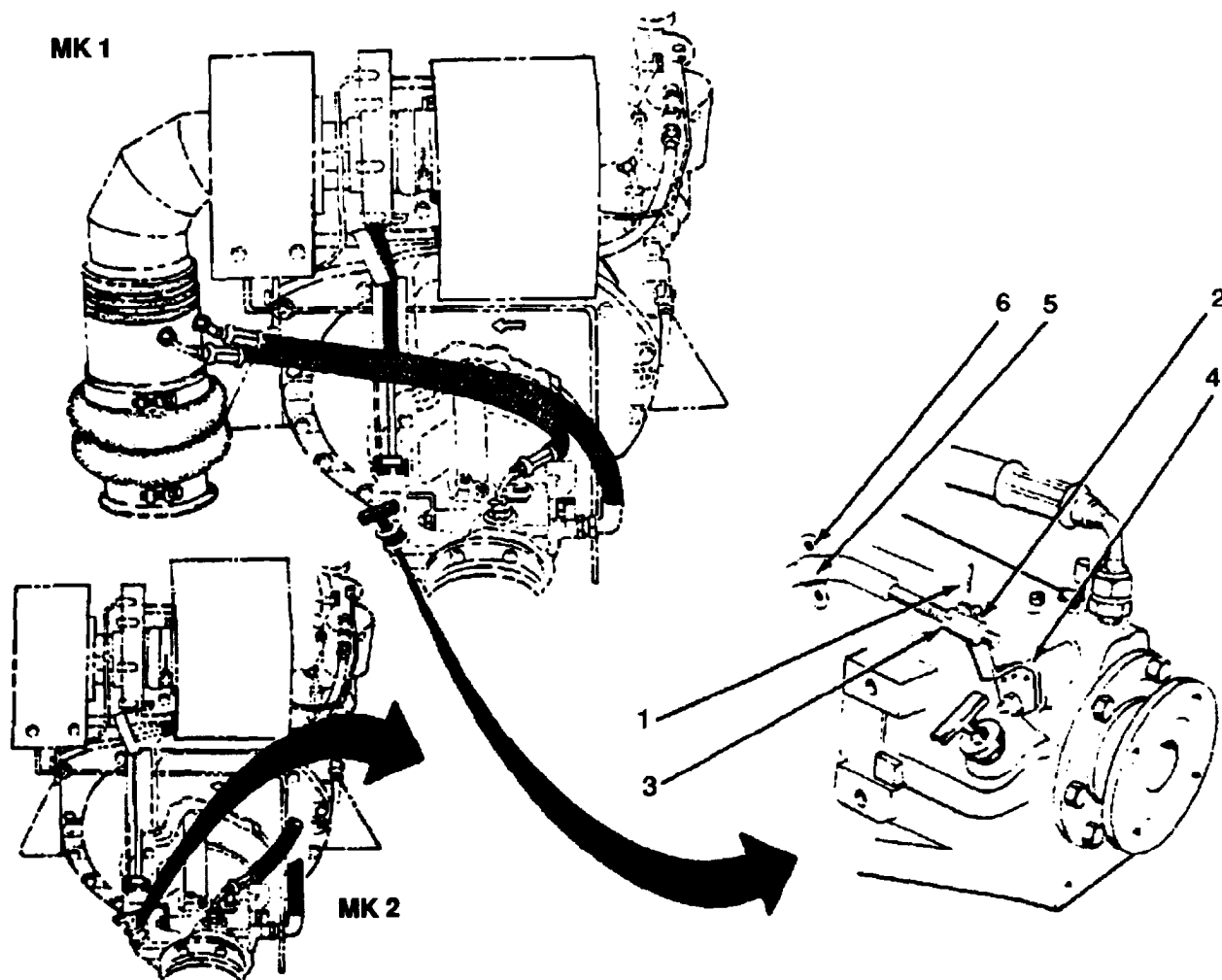

CAUTION

The cable should NOT be bent sharply in any direction. Severe cable damage may result.

NOTE

Port transmission cable is 27'1" in length. Starboard transmission cable is 25'5" in length.

REMOVE:

1. Open and secure engine hatches (refer to paragraph 3-154).
2. Remove control head assembly (refer to paragraph 3-34).
3. Using pliers remove and discard cotter pin (1) securing cable pivot (2) to transmission control (3).
4. Remove cable pivot (2) from transmission control (4).
5. Remove cable pivot (2) and nut (3) from old (8) and new (7) cable.
6. Using 5/16 inch open end wrench remove transmission cable damp (5) and two bolts and nuts (6).

INSTALL:

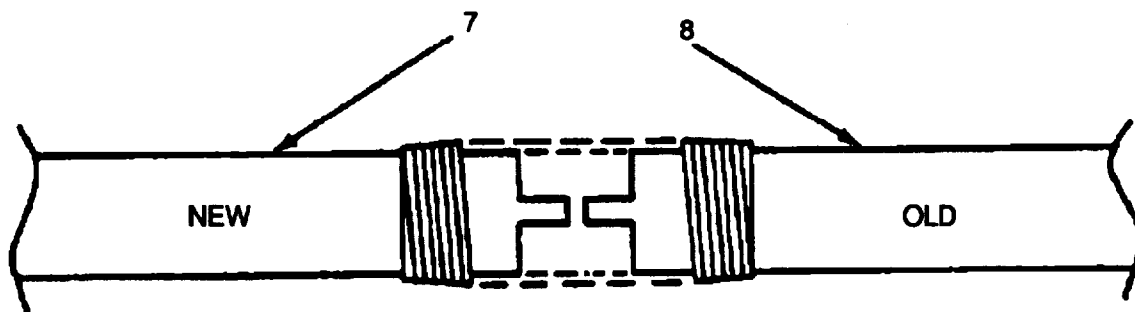

1. Butt end of new cable (7) to end of old cable (8) at transmission and wire ends together securely using solid wire.
2. Pull new cable (7) into position at control head assembly.
3. Unwire new cable (7) from old cable (8).
4. Reinstall cable pivot (2) end nut (3) on new cable (7).
5. Adjust cable linkage (refer to paragraph 3-36).
6. Reinstall control head assembly (refer to paragraph 3-34).
7. Install cable pivot (2) into transmission control (4).
8. Using pliers install cotter pin (1) securing cable pivot (2) to transmission control (4).
9. Flare end of cotter pin (1).
10. Using 5/16 inch open end wrench reinstall transmission cable damp (5) and two nuts and bolts (6).
11. Close engine hatches.

3-39. ENGINE THROTTLE CABLE REPLACEMENT INSTRUCTIONS

TOOLS: 7/16 inch Open End Wrench
flat lip Screwdriver, 4 inch
Long Nose Pliers

PARTS/MATERIALS: Two Feet, Solid Wire (Recommend 18 Gauge Wire)
Morse Teleflex Throttle Cable
1/8 inch diameter Cotter Pin

PERSONNEL REQUIRED: Two

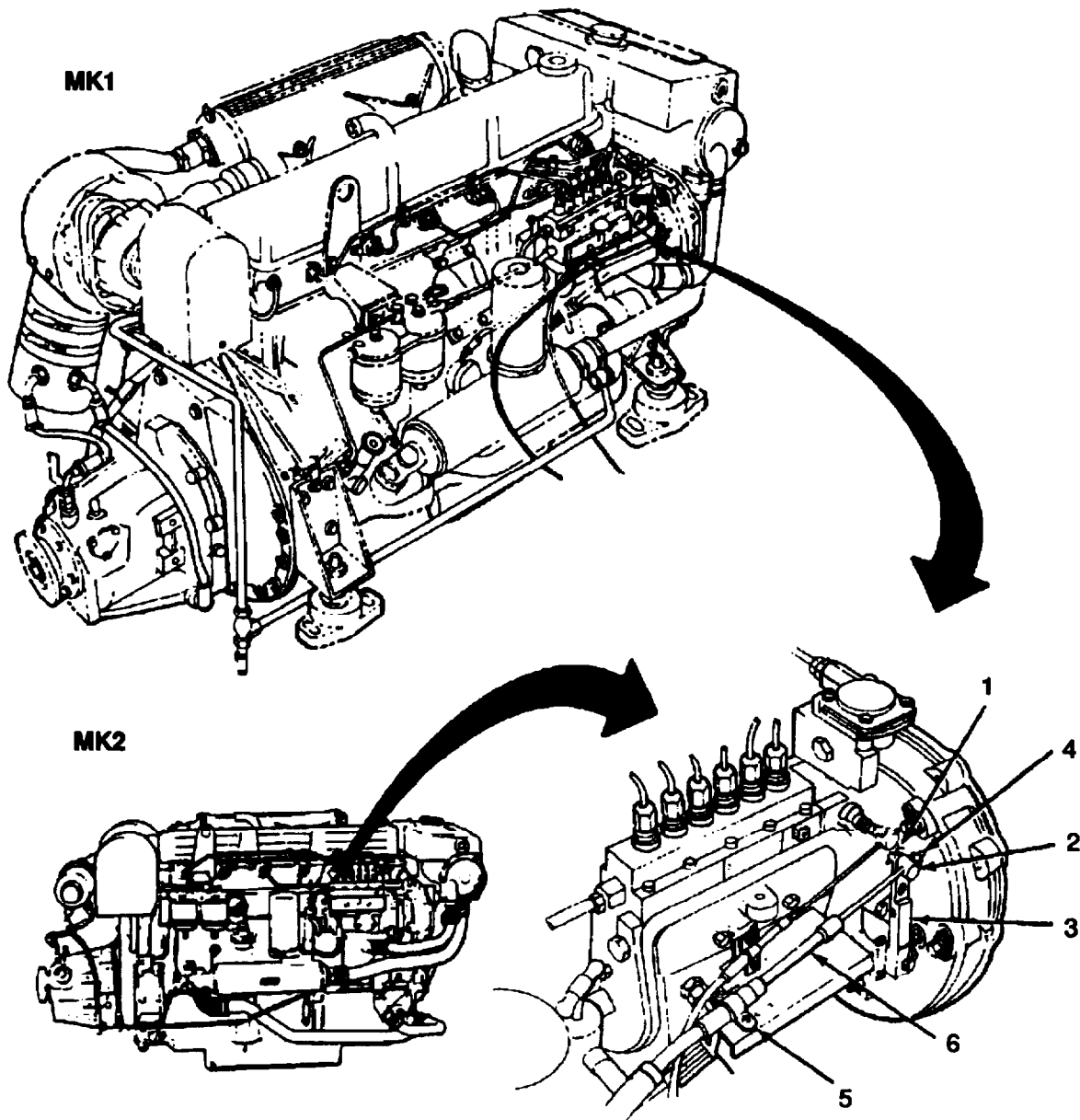

CAUTION

The cable should NOT be bent sharply in any direction. Severe cable damage may result.

NOTE

Port throttle cable is 24'6" in length. Starboard throttle cable is 26'4" in length.

REMOVE:

1. Open and secure engine hatches (refer to paragraph 3-154).
2. Remove control head assembly (refer to paragraph 3-34).
3. Using pliers remove and discard cotter pin (1) securing cable pivot (2) to throttle control (3).
4. Remove cable pivot (2) from throttle control (3).
5. Holding stop nut (4) with 7/16 inch wrench unscrew cable pivot from cable (6).
6. Unscrew stop nut (4) from cable (6).
7. Using screwdriver remove throttle cable damp (5).

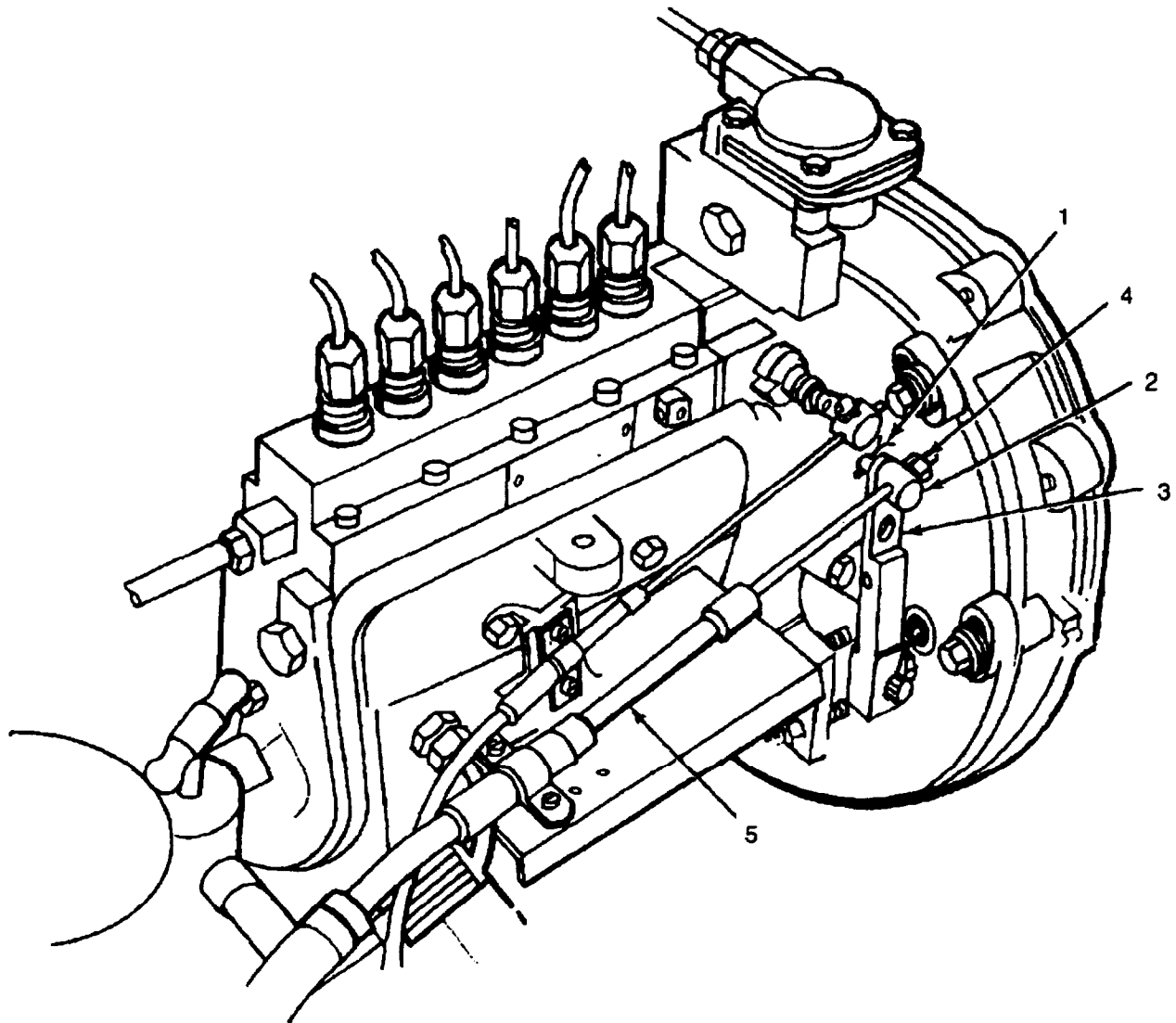

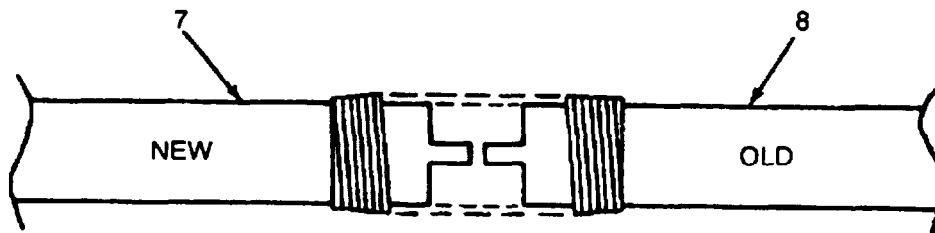

INSTALL

1. Butt end of new cable (7) to end of old cable (8) at injection pump. Wire cable ends together securely using solid wire.
2. Pull new cable (7) into position at control head assembly.
3. Unwire new cable (7) from old cable (8).
4. Reinstall control head assembly (refer to paragraph 3-34).
5. Screw stop nut (4) onto cable.
6. Screw pivot (2) onto cable.
7. Using screwdriver reinstall throttle cable clamp (5).
8. Install cable pivot (2) into throttle control (3).
9. Adjust throttle control (3) (refer to paragraph 3-37).
10. Using pliers install new cotter pin (1) securing cable pivot (2) to throttle control (3).
11. Flare end of cotter pin (1).
12. Close engine hatches.

3-40. ENGINE STOP CONTROL HANDLE REPLACEMENT INSTRUCTIONS

TOOLS: 11 mm Open End Wrench

PARTS/MATERIALS: Control Handle

REMOVE:

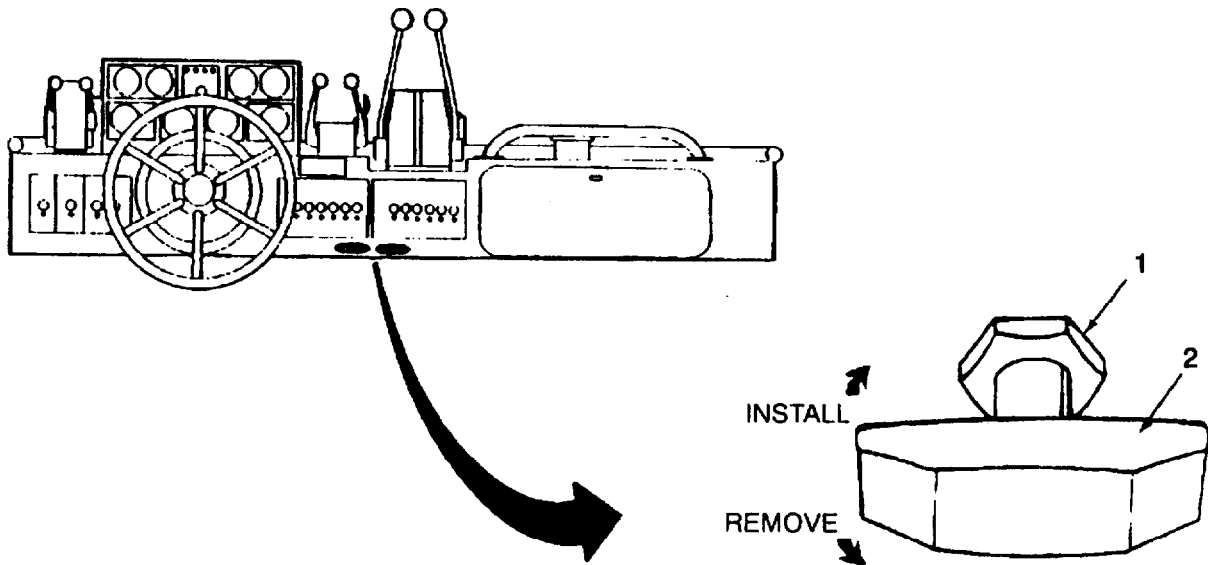

1. Using wrench hold cable stop nut (1) and unscrew engine stop control handle (2) from cable as shown above.
2. Replace stop control handle.

INSTALL:

1. Screw engine stop control handle (2) onto cable holding cable stop nut (1) with wrench as shown above.

3-41. ENGINE STOP CONTROL CABLE REPLACEMENT INSTRUCTIONS

TOOLS: Two 9/16 inch Open End Wrenches

11 mm Open End Wrench

8 mm Open End Wrench

Flat Tip Screwdriver, 4 inch

10 mm Open End Wrench

PARTS/MATERIALS: Morse Teleflex Engine Stop Cable (22'3")

Two Feet, Solid Wire (Recommend 18 Gage Wire)

PERSONNEL REQUIRED: Two

CAUTION

The cable should not be bent sharply in any direction. Severe cable damage may result.

REMOVE:

1. Open and secure engine hatches (refer to paragraph 3-154).

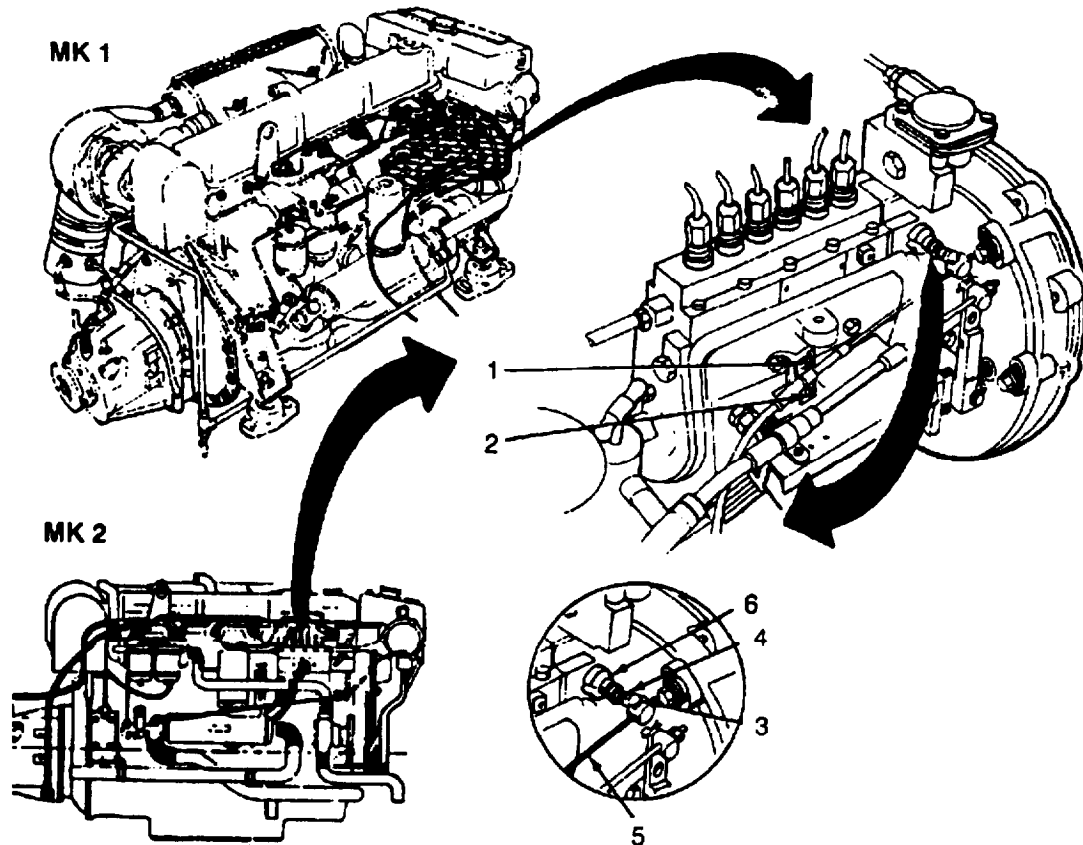

2. Using screwdriver remove two screws (1) and engine stop cable clamp (2).
3. Using 8 mm wrench on screw (3) and 10 mm wrench to hold control arm (4) remove cable wire (5) from shutoff control (6).

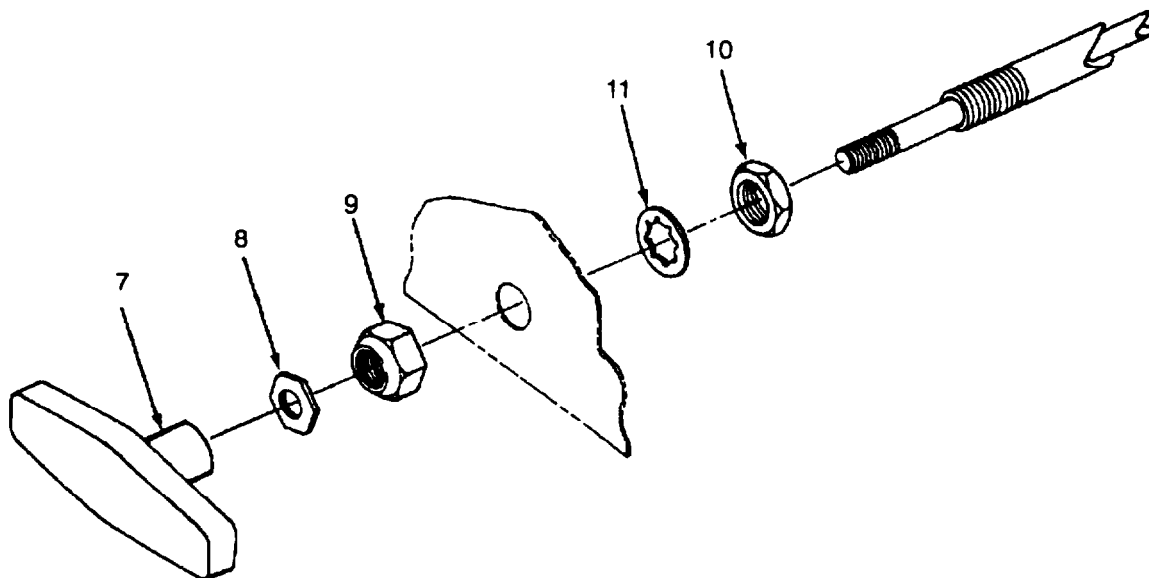

4. Using 11 mm open end wrench, hold retainer nut (8) and unscrew engine stop control handle (7) at console.
5. Using 11 mm open end wrench remove small retainer nut (8) from cable end.
6. Using two 9/16 inch open end wrenches remove outer retaining nut (9) from cable end.
7. Push cable end through console.
8. Using 9/16 inch open end wrench remove nut (10) and washer (11) from cable end.

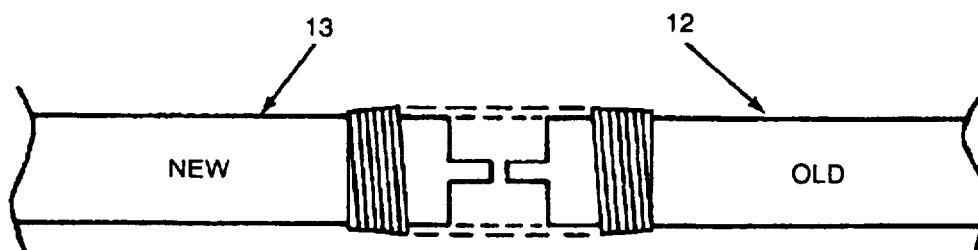

INSTALL:

1. Butt ends of old cable (12) and new cable (13) at injection pump. Wire cable ends together securely using 18 gage wire.
2. Pull new cable (13) into position at console.
3. Remove old cable (12) from new cable (13).
4. Using 9/16 inch open end wrench reinstall retaining nut (10) and inner washer (11) to cable end.
5. Push cable through console as far as inner retaining nut (10) will allow.
6. Using two 9/16 inch open end wrenches reinstall outer retaining nut (9) on cable end.
7. Using 11 mm open end wrench reinstall small retainer nut (8) on cable end.
8. Screw on engine stop control handle (7) at console while holding retainer nut (8) with 11 mm wrench.
9. Push engine stop control handle (7) fully against console.

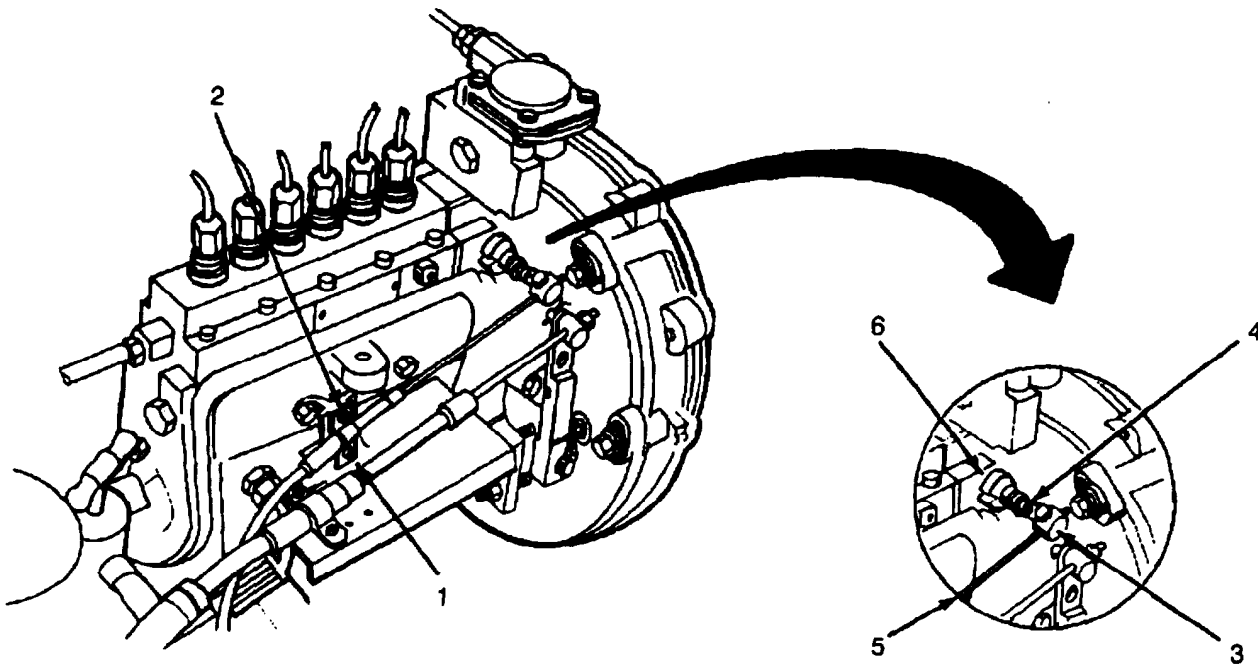
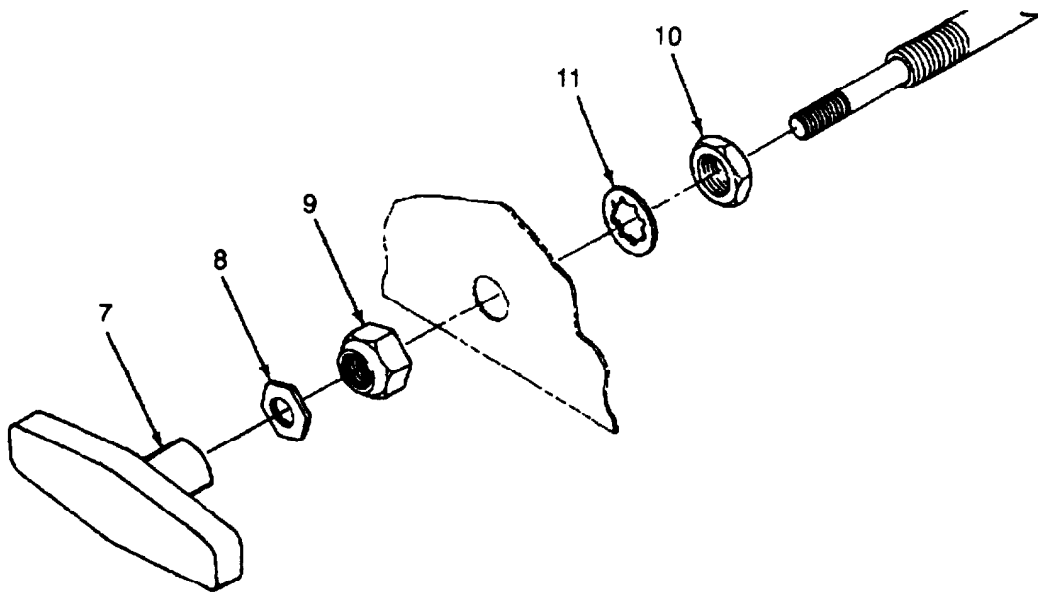

NOTE

Engine shutoff control must be in "RUN" position.

10. Using 8 mm wrench on screw (3) and 10 mm wrench on control arm (4) reinstall cable wire (5) on engine shutoff control (6).
11. Using screwdriver reinstall engine stop cable clamp (2) and two screws (1).
12. Close engine hatches.

3-42. STEERING CABLE REPLACEMENT INSTRUCTIONS

TOOLS: 1/2 inch Box Wrenches

Long Nose Pliers

9/16 inch Box Wrench

9/16 inch Socket

Ratchet

Flat Tip Screwdriver

13 mm Box Wrench

PARTS/MATERIALS: Steering Cable

Two Feet of Solid Wire (Recommend 18 Gage)

PERSONNEL REQUIRED: Three



Set master switch to "OFF". Shock or burns may result.

CAUTION

The cable should not be bent sharply in any direction. Severe cable damage may result.

REMOVE:

1. Remove steering wheel assembly (refer to paragraph 3-44).

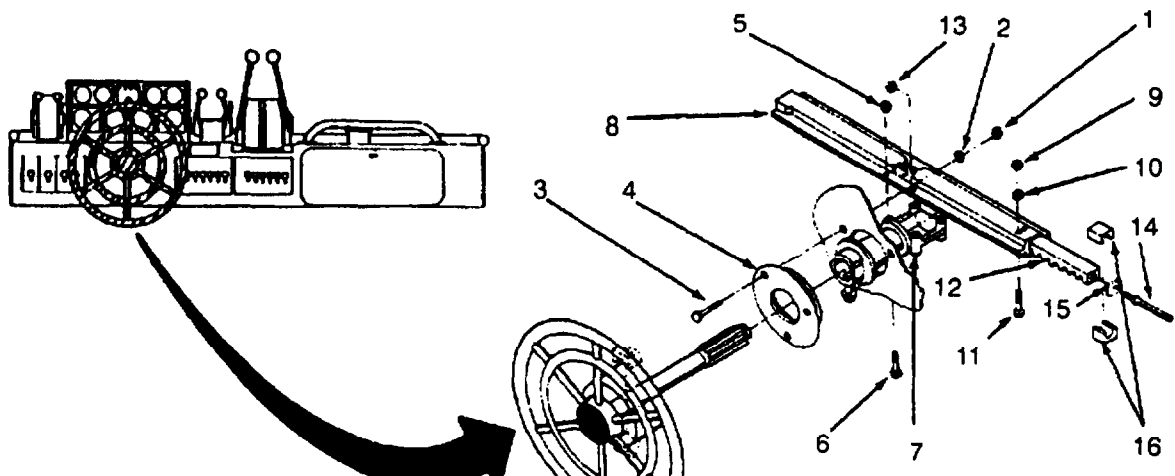

2. Using two wrenches remove three nuts (1), washers (2) and bolts (3) securing steering support ring (4) to console.
3. Using two wrenches remove four nuts (5) and bolts (6) holding steering gear carriage (7) to gear slide casing (8).
4. Remove steering gear carriage (7).
5. Using two wrenches remove two nuts (9) washers (10) and bolts (11) holding gear slide (12) to gear slide casing (8).
6. Remove gear slide (12) from gear slide casing (8).
7. Using wrench remove self-locking nut (13) securing gear slide (12) to cable end (14).
8. Remove end cap (15) cable bracket top and bottom (16).
9. Remove cable end (14) from gear slide (12).

10. Open and secure hydrojet hatches (refer to paragraph 3-154).

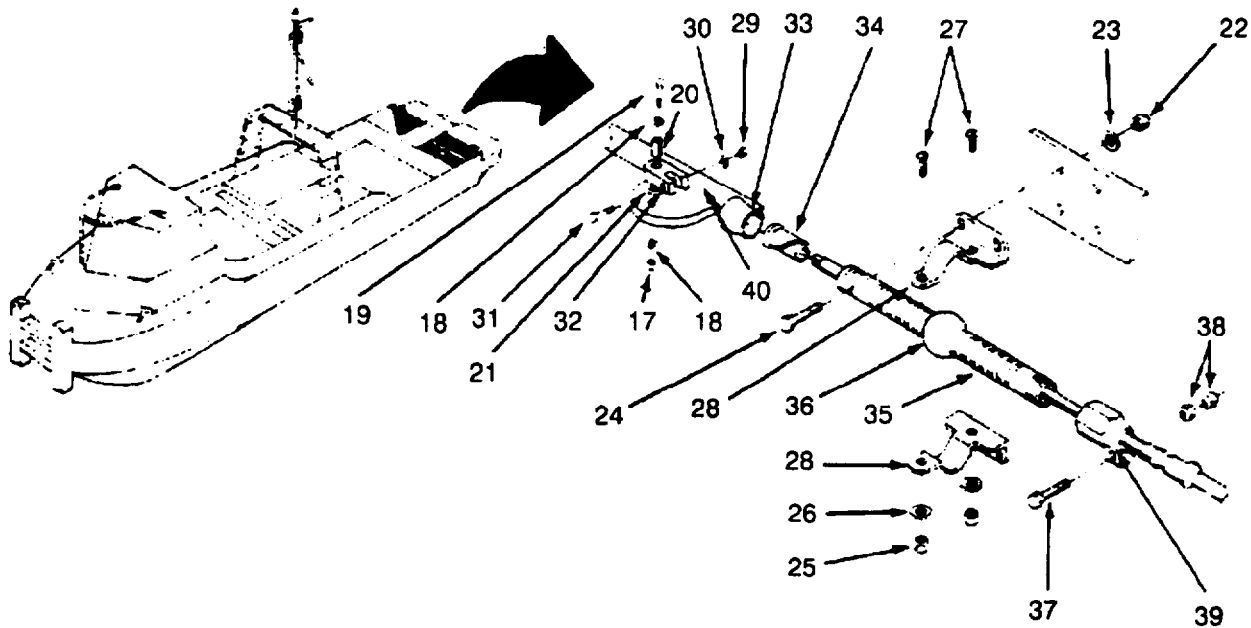

11. Using 9/16 inch wrench and socket remove nut (17), two washers (18), bolt (19), spacer (20) and spacer (21).
12. Using 11/2 inch and 13 mm box wrenches remove two nuts (22), two washers (23), and two bolts (24). Remove damp (28).
13. Using 7/16 inch wrench and screwdriver remove two nuts (25), two washers (26), two bolts (27) and damp (28).
14. Using 9/16 inch wrench and socket remove nut (29), washer (30), bolt (31) and cable control yoke (32).
15. Remove bushing (33), insert (34), cable adjustment sleeve (35) and damp spaces (36).
16. Using two 7/16 inch wrenches loosen bolt (37) and nuts (38) securing cable stop (39).
17. Remove cable stop (39).
18. Remove aft cockpit (refer to paragraph 3-27).
19. Remove part side buoyancy flotation material (refer to paragraph 3-152).

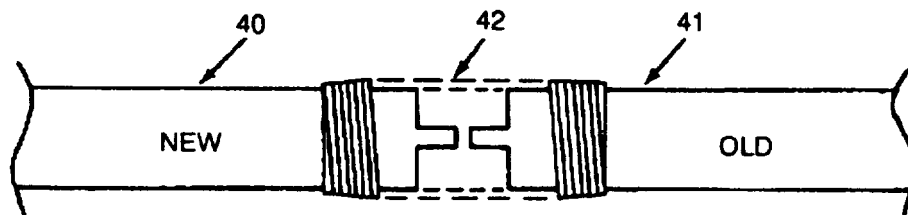

20. Butt end of new cable (40) to end of old cable (41) (at stem). Wire cable ends together to form a secure bond (42).
21. Using three people, pull new cable into position at steering control assembly.
22. Unwire new cable (40) from old cable (41).

INSTALL:

1. Install end cap (15) on cable end (14).
2. Install slide gear (12) onto cable end (14).
3. Install cable bracket top and bottom (16).
4. Using wrench install self-locking nut (13) securing slide gear (12) to cable end (14).
5. Install gear slide casing (8) over gear slide (12) (gear teeth must be visible in casing slot).
6. Using two wrenches install two bolts (11), washers (10) and nuts (9) securing gear slide casing (8) to gear slide (12).
7. Install steering gear carriage (7) into console.
8. Using two wrenches install four bolts (6) and nuts (5) securing steering gear carriage (7) to gear slide casing (8).
9. Install steering support ring (4) in console. Using two wrenches install three bolts (3), washers (2) and nuts (1) securing steering support ring (4) to console.
10. Reinstall steering wheel assembly (refer to paragraph 3-44).
11. Reinstall cable stop (39) and tighten nuts (38) using two wrenches.
12. Reinstall cable adjustment sleeve (35), insert (34), and bushing (33).
13. Reinstall damp spacers (upper and lower section) (36) and, using screwdriver and 7/16 inch wrench, install damp (28) and two bolts (27), two washers (26) and two nuts (25) securing damp to cable adjustment sleeve.
14. Reinstall two bolts (24), two washers (23) and two nuts (22). Tighten using two 7/16 inch wrenches.
15. Reinstall cable control yoke (32), bolt (31), washer (30) and nut (29). Tighten using 9/16 inch wrench and socket.
16. Reinstall bolt (19), spacer (20), spacer (21), two washers (18) and nut (17) securing cable control yoke (32) to tierod (40). Tighten using 9/16 inch wrench and socket.
17. Reinstall port buoyancy flotation material (refer to paragraph 3-152).
18. Reinstall aft cockpit (refer to paragraph 3-27).
19. Close hydrojet hatches.

3-43. STEERING WHEEL ASSEMBLY REPAIR INSTRUCTIONS

TOOLS: Non-metallic Hammer

Mechanical Puller

Snap Ring Pliers

3/32 inch Hex Key Wrench (Allen)

Two 7/16 inch Box Wrenches

15/16 inch Socket

Long Nose Pliers

Ratchet

PARTS/MATERIALS: Steering Gear Carriage Assembly



Set master switch to "OFF". Severe burns and shocks may result.

REMOVE:

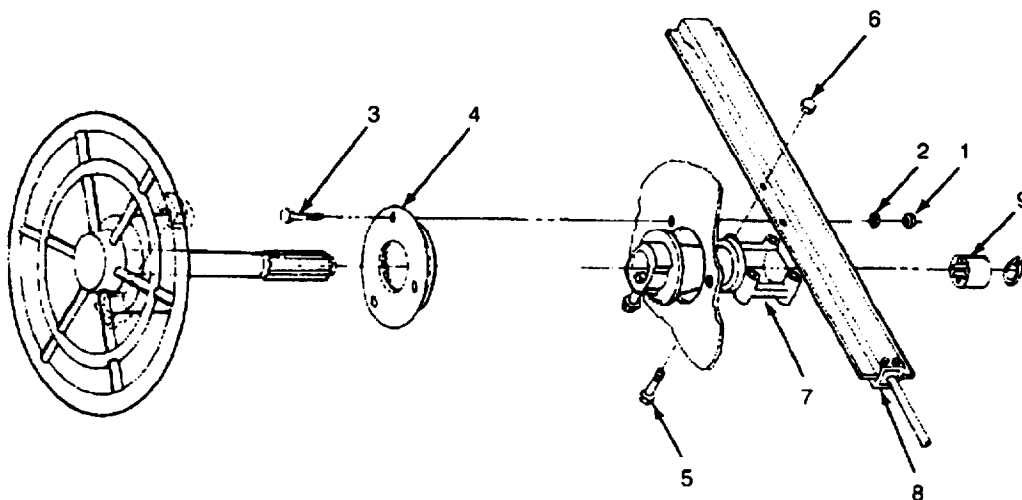

1. Open access panel under control console (refer to paragraph 3-154).
2. Remove steering wheel assembly (refer to paragraph 3-44).
3. Using two 7/16 inch box wrenches remove three nuts (1), washers (2) and bolts (3) securing steering support ring (4) to console.
4. Using two 7/16 inch box wrenches remove four nuts (5) and bolts (6) securing steering gear carriage assembly (7) to gear slide casing (8).
5. Remove steering gear carriage assembly (7) and plastic sleeve (9).

INSTALL:

1. Install new steering gear carriage assembly (7) into console.
2. Using two 7/16 inch box wrenches reinstall four bolts (6) and nuts (5) securing steering gear assembly (7) to gear slide casing (8).
3. Using two 7/16 inch box wrenches reinstall three bolts (3), washers (2) and nuts (1) securing steering support ring (4) to console.
4. Reinstall steering wheel assembly (refer to paragraph 3-44).

3-44. STEERING WHEEL ASSEMBLY REPLACEMENT INSTRUCTIONS

TOOLS: Two 7/16 inch Box Wrenches
Snap Ring Pliers

PARTS/MATERIALS: Steering Wheel Assembly



Set master switch to "OFF". Severe burns and shocks may result.

REMOVE:

1. Open access panel under control console (refer to paragraph 3-154).

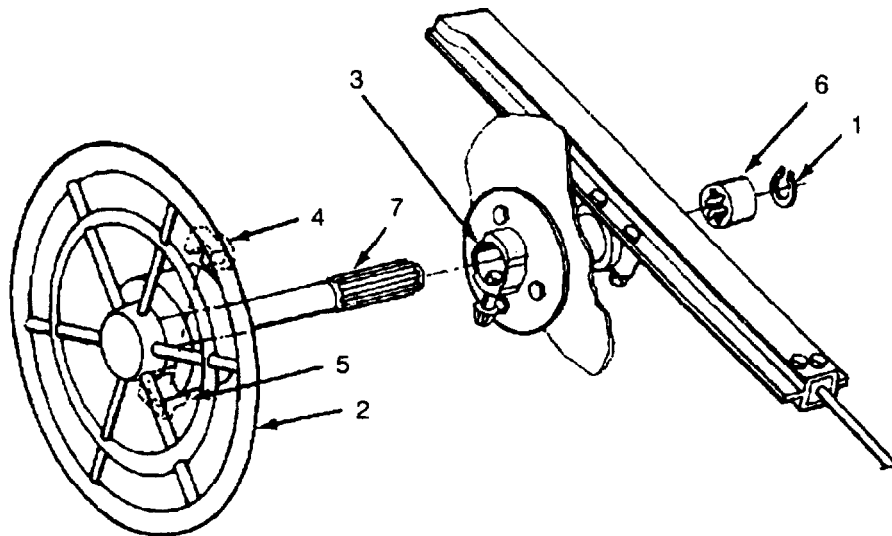

2. Using pliers remove snap ring (1) at forward end of hub (located beneath console).
3. Gently slide steering wheel assembly (2) from steering gear carriage (3) and remove two-piece plastic insert (4) from steering wheel shaft.

INSTALL:

1. Slide new steering wheel assembly (2) into steering gear carriage (3) but do not seat fully.
2. Place two-piece plastic insert (4 and 5) around steering wheel shaft with raised portion of upper insert (4) toward steering wheel.
3. Seat steering wheel assembly fully in steering gear carriage (3).
4. Install new plastic sleeve (6) over steering wheel shaft (7).
5. Using pliers reinstall snap ring (1) at forward end of steering wheel shaft.
6. Close access panel.

3-45. STEERING TIE ROD ADJUSTMENT INSTRUCTIONS

TOOLS: 9/16 inch Open End Wrench
9/16 inch Socket
Ratchet
3/4 inch Open End Wench, 2 each

PERSONNEL REQUIRED: Two

ADJUST

NOTE

The boat must be out of water on cradle or hardstand to perform this service.

1. Open and secure hydrojet hatches (refer to paragraph 3-154).
2. Open steering unit hatches (refer to paragraph 3-28).
3. Turn steering wheel (1) until scoop position indicator (2) is on zero.

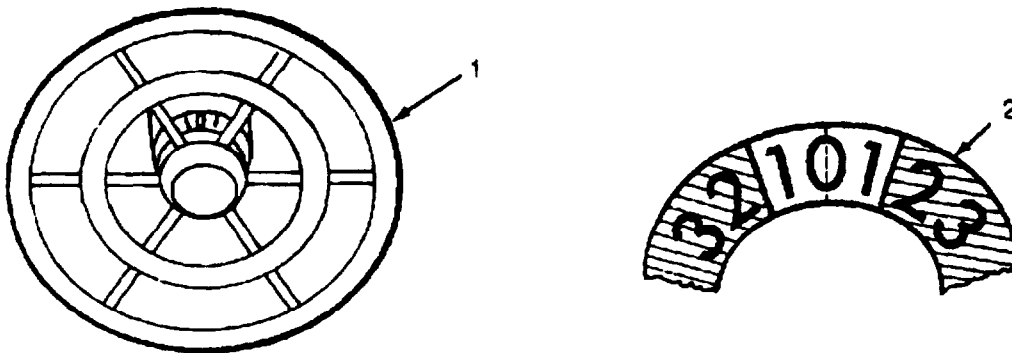

4. Holding nut (3) with 9/16 inch wrench, remove nut (4), lockwasher (5) and flat washer (6) using socket and ratchet.

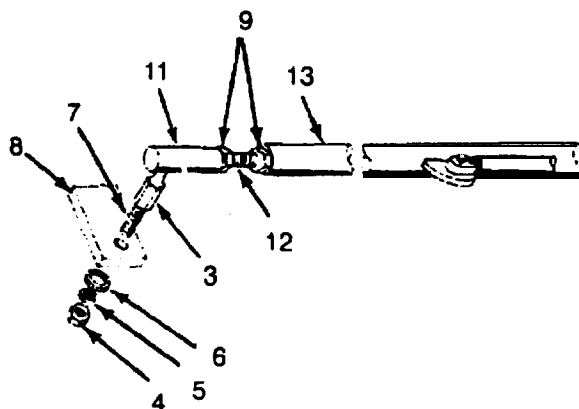

5. Pull linkage pin (7) out of hole in inner steering arm (8).

6. Hold one nut (9) with 3/4 inch wrench and loosen other nut (9) using second 3/4 inch wrench.
7. Loosen first nut using 3/4 inch wrench.

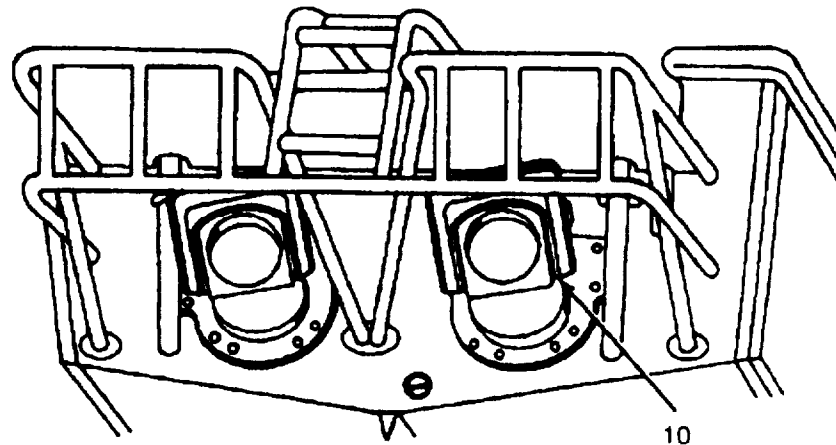

8. Have one person position scoop (10) in straight up and down position
9. Adjust tie rod length by turning tie rod end (11) screwing adjusting link (12) in or out of tie rod end (11) and/or tie rod (13).
10. Run nuts (9) out to ends of adjusting link (12), tighten finger tight.
11. Tighten nuts (9) using 3/4 inch wrench.
12. Insert linkage pin (7) through hole in inner steering arm (8).
13. Install flat washer (6), lockwasher (5) and nut (4) on linkage pin (7).
14. Holding nut (3) with 9/16 inch wrench, tighten nut (4) using socket and ratchet.
15. Close and secure steering unit hatches.
16. Close hydrojet hatches.

3-46. STEERING TIE ROD INSPECTION AND REPLACEMENT INSTRUCTIONS

TOOLS: 9/16 inch Open End Wrench
9/16 inch Socket
Ratchet
3/4 inch Open End Wrench

REMOVE:

1. Open and secure hydrojet hatches (refer to paragraph 3-154).

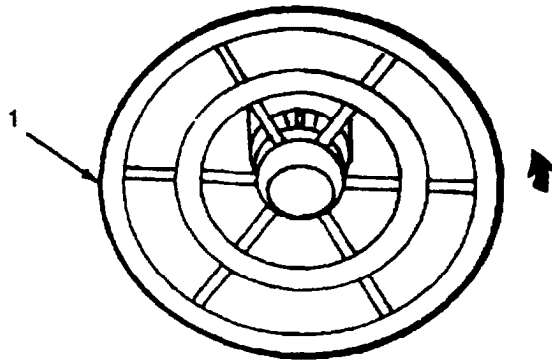

2. Turn steering wheel (1) to full left (port) turn.

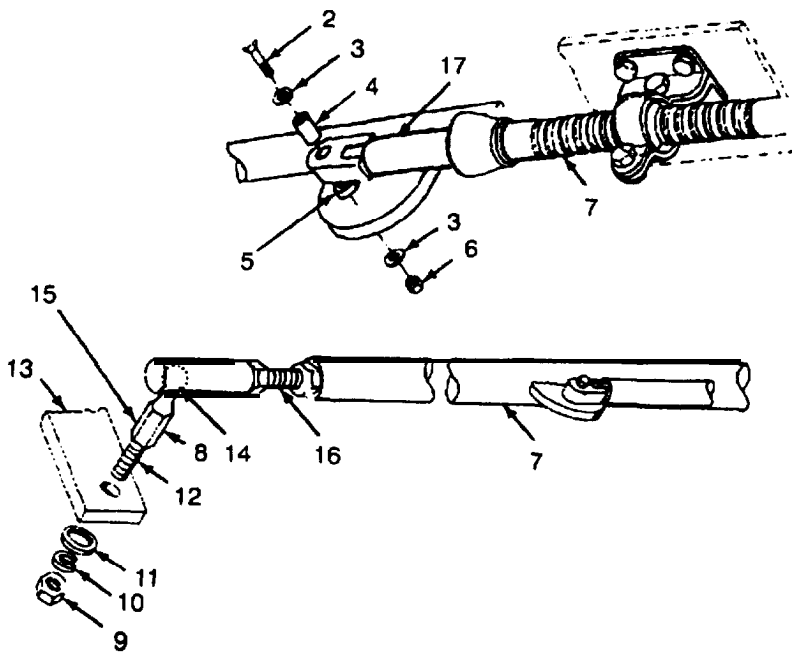

3. Remove bolt (2), two washers (3), spacer (4), spacer (5) and nut (6) using 9/16 inch wrench, socket and ratchet. **This disconnects steering cable from tie rod (7).**

4. Holding nut (8) with 9/16 inch wrench, remove nut (9), lockwasher (10) and flat washer (11) using socket and ratchet.
5. Pull linkage pin (12) out of hole in inner steering arm (13).
6. Repeat steps 4 and 5 for opposite end of tie rod and remove tie rod.

INSPECTION:

1. Inspect thread on adjusting link (16) and linkage pin (12) for serviceability.
2. Inspect tie rod (7) for straightness.
3. Inspect linkage pin (12), ball joint end (14) for damage, neck between ball and threaded body (15) for wear.
4. Replace tie rod if any of the above defects are noted.

INSTALL:

1. Position tie rod across port and starboard inner steering arms (13).
2. Insert linkage pin (12) through hole in inner steering arm (13).
3. Install flat washer (11), lockwasher (10) and nut (9) on linkage pin (12).
4. Holding nut (8) with 9/16 inch wrench, tighten nut (9) using socket and ratchet.
5. Repeat steps 2, 3 and 4 for opposite end of tie rod (7).
6. Install bolt (2), two washers (3), spacer (4), spacer (5) and nut (6) securing steering cable (17) to tie rod (7). Use 9/16 inch wrench and socket to tighten.
7. Check tie rod adjustment (refer to paragraph 3-45).
8. Close hydrojet hatches.

3-47. INSTRUMENT PANEL COMPONENT REPLACEMENT INSTRUCTIONS

TOOLS: Cross Tip Screwdriver
7 mm Box Wrench
16 mm Open End Wrench
Long Nose Pliers

PARTS/MATERIALS: Gage Lamp
Warning Lamp
Water Temperature Gage
Oil Pressure Gage
Tachometer
Voltmeter
Switch
Insulating Plastic Spray Paint

REMOVE:

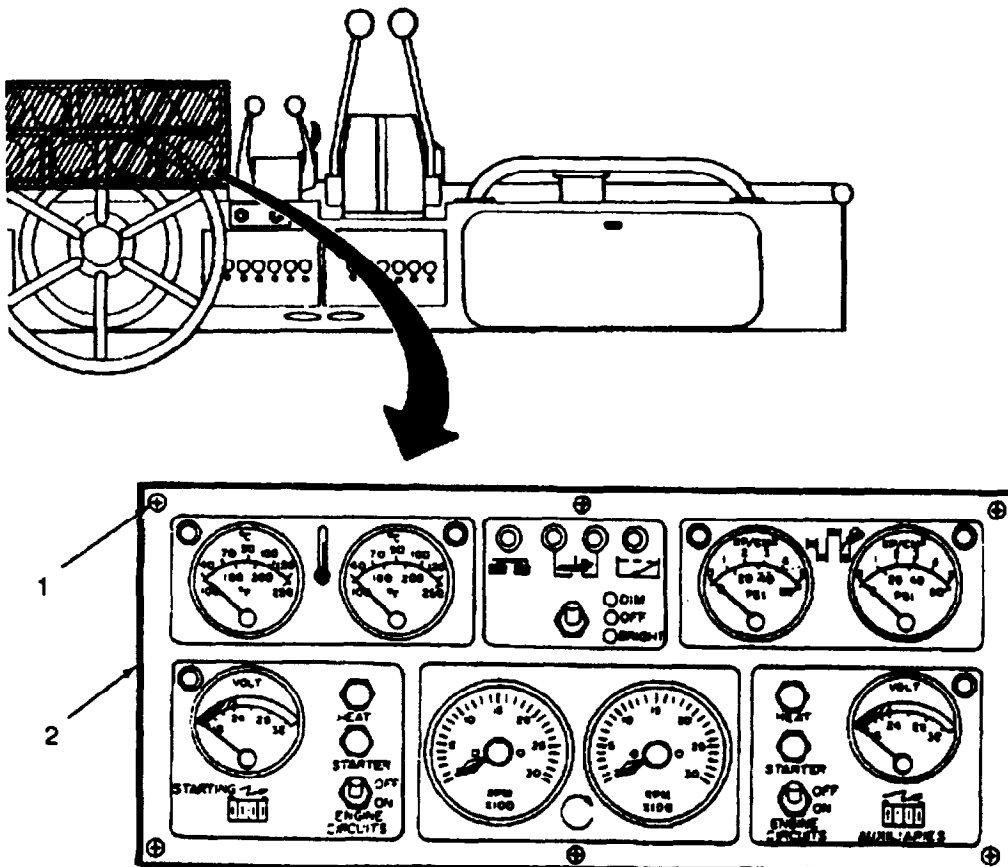

1. Using cross tip screwdriver remove six screws (1) securing instrument panel (2).
2. Lower instrument panel.

NOTE

After step 2 go to step that covers the replacement of specific item.

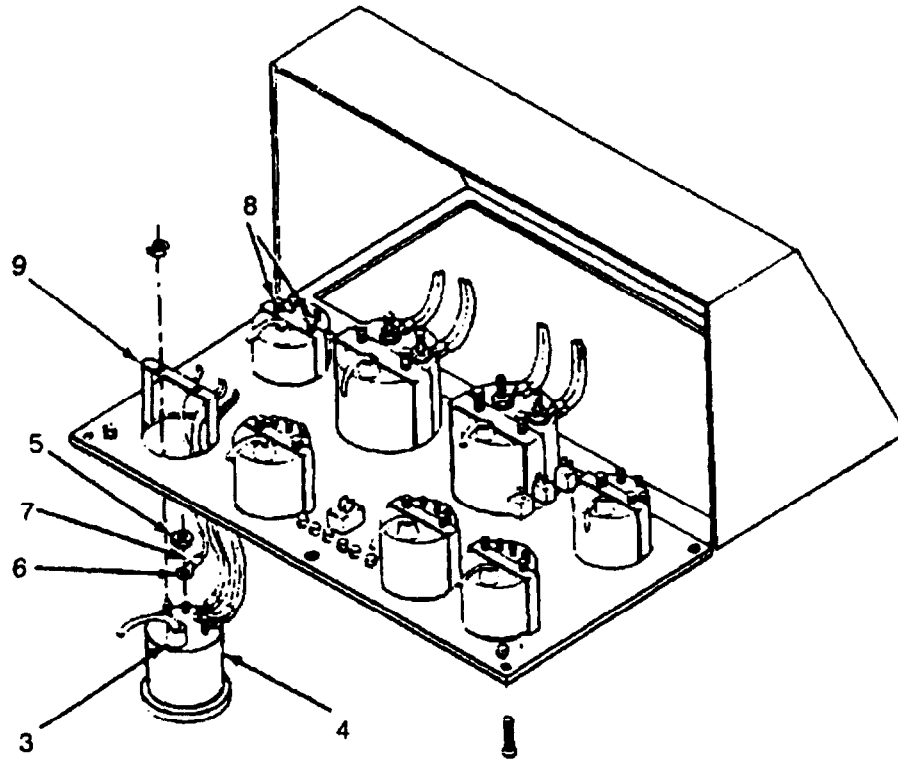

NOTE

Gage lamp replacement procedure is same for all gages.

REMOVE: Gage Lamp

1. Remove gage lamp socket (3) by pulling rubber cover and socket free from gage (4).
2. Remove lamp by pushing in and turning counterclockwise 1/4 turn.

REPLACE: Gage Lamp

1. Insert new gage lamp into socket (3) by pushing in and turning clockwise 1/4 turn to lock in place.

REMOVE: Gage

NOTE

Gage replacement procedure is same for all gages, only difference is number of wires to different gages.

1. Remove gage lamp socket (3) (refer to step 1, gage lamp removal).
2. Using 7 mm box wrench remove nuts (5) securing washers (6) and wires (7) to gage terminals.
3. Hold gage (4) on front side of panel and remove two knurled nuts (8) and bracket (9).
4. Remove gage (4) from front of panel.

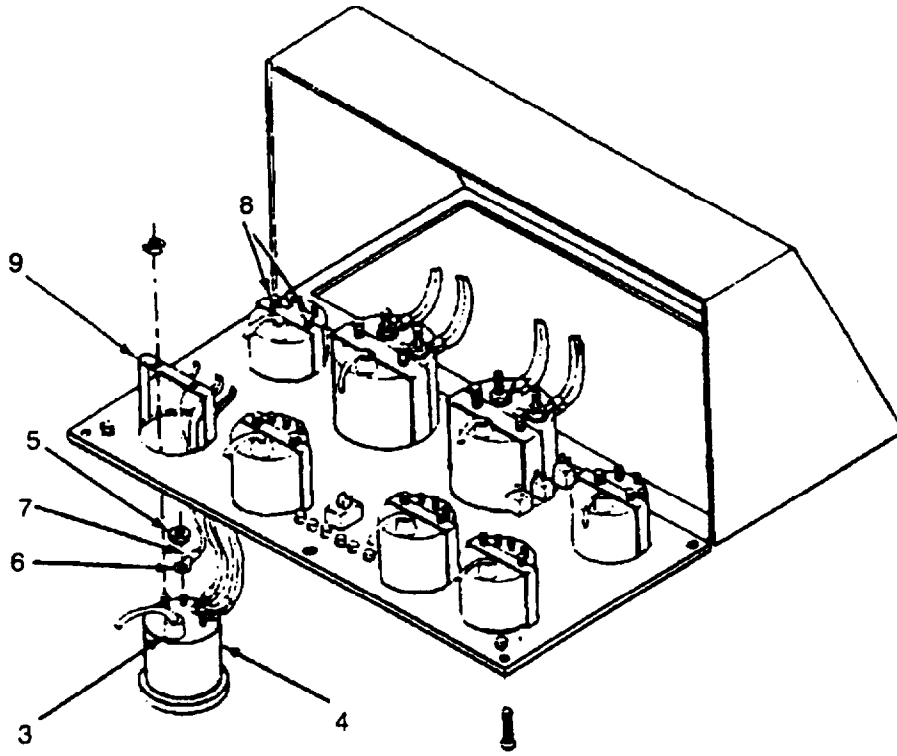

REPLACE: Gage

1. Insert lamp in gage lamp socket (3) and turn clockwise to lock in place.
2. Insert gage (4) from front of panel.
3. Insert socket (3) and rubber cover in hole on back of gage (4).
4. Hold gage (4) in proper position and replace bracket (9) and knurled nuts (8).
5. Hand tighten knurled nuts (8).
6. Replace wires (7) and washers (6) on terminals (refer to wiring diagram, page FO-1).
7. Install nuts (5) and tighten using 7 mm box wrench.

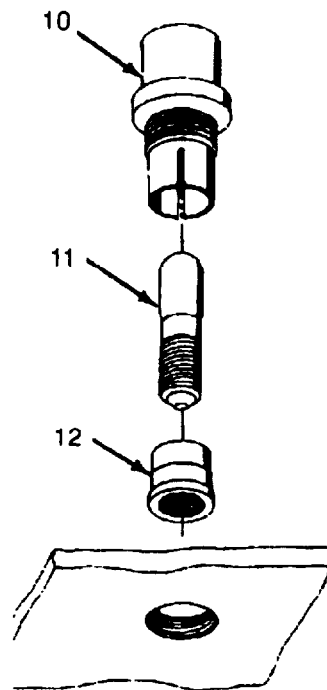

REMOVE: Warning Lamp

NOTE

Warning lamp can be replaced without removing instrument panel.

1. Unscrew warning lamp lens (10) by hand to remove lens, lamp (11) and collar (12) from socket.
2. Unscrew collar (12) and remove lamp (11).

REPLACE: Warning Lamp

1. Turn new warning lamp (11) into collar (12).
2. Insert lamp (11) and collar (12) in lens (10) by pushing lamp in place.
3. Screw warning lamp lens (10) into socket by hand.

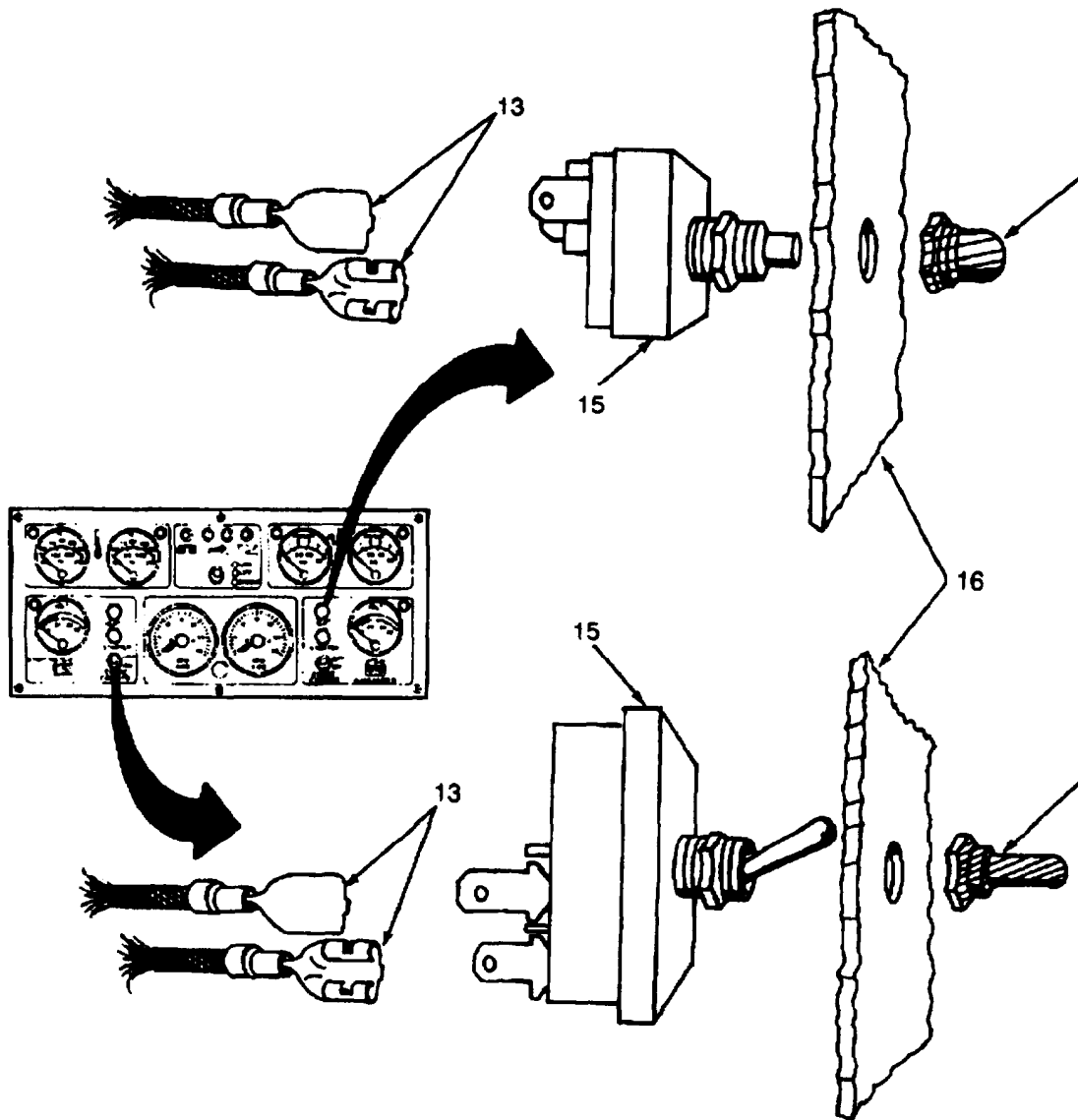

NOTE

Switch can be removed without removing instrument panel.

1. Remove wire leads (13) by pulling push-on connectors loose from switch using pliers.
2. Hold switch on back side of panel and remove locking nut (14) using 16 mm wrench.
3. Remove switch (15) from panel (16).

REPLACE: Switch

1. Insert switch (15) into panel (16) from back side.
2. Hold switch (15) in proper position and install locking nut (14) on switch (15) finger tight.
3. Tighten locking nut (14) using 16 mm wrench while holding switch in position on back side of panel.
4. Reconnect two wire leads (13) by pushing connectors onto terminals using pliers.

REINSTALL: Instrument Panel

1. Position panel (2) in opening on console.
2. Secure panel (2) with six screws (1) using cross tip screwdriver.

3-48. HEAT/START AND TOGGLE SWITCH TEST

TOOLS: Long Nose Pliers

Multimeter

PERSONNEL REQUIRED: Two

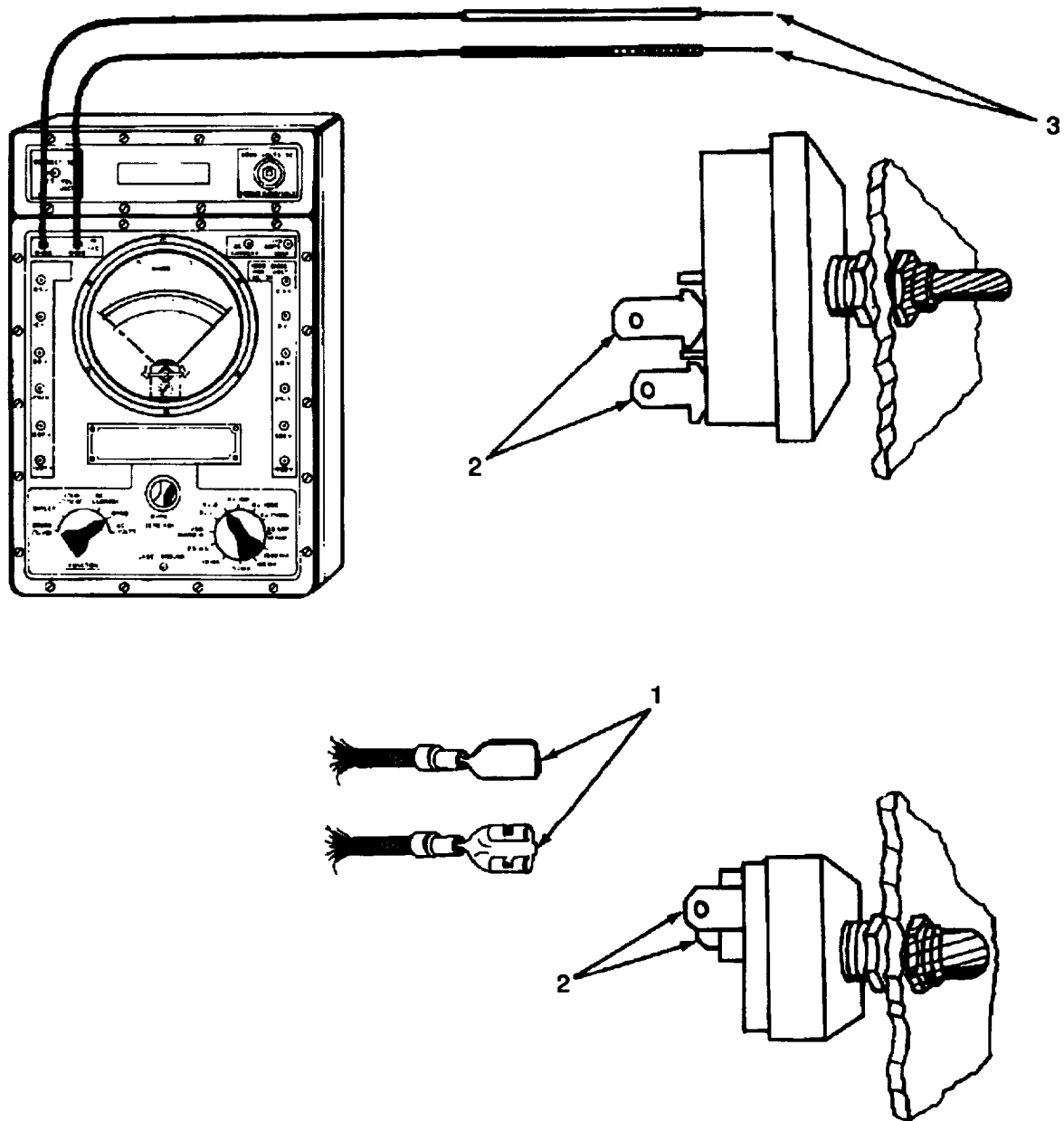

- 1 . Open access panel under control console (refer to paragraph 3-154).
- 2 . Using long nose pliers pull two connectors (1) loose from switch terminals (2).
- 3 . Set multimeter to OHMS X 10.
- 4 . One person connect multimeter probes (3) to switch terminals (2).
- 5 . Second person push switch in.
 - If meter reads other than 0 switch is good. Go to step 6.
 - If meter reads 0 switch is bad. Go to step 8.
- 6 . Push connector (1) on terminals (2).
- 7 . Close access panel (refer to paragraph 3-154).
- 8 . Replace switch (refer to paragraph 3-47).

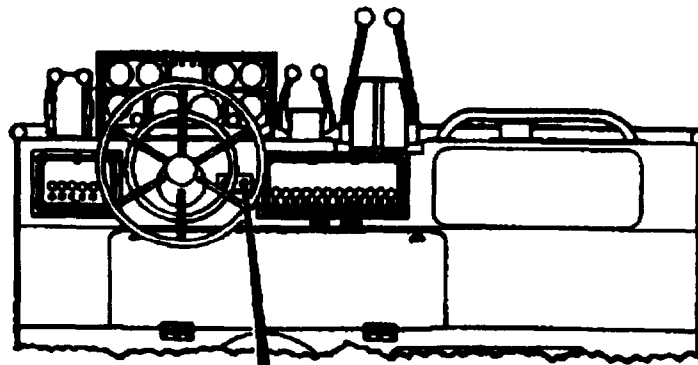

MK-1 AND MK-2

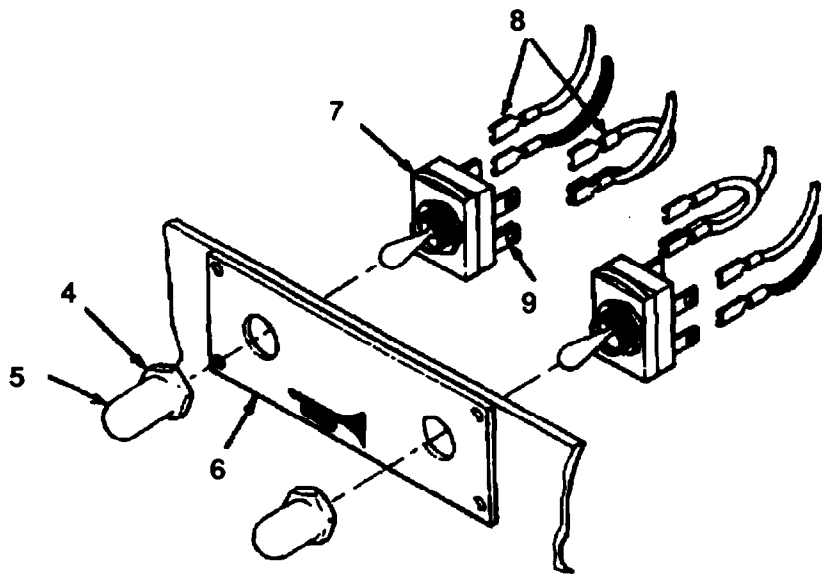

3-49. ENGINE ALARM MUTE SWITCH REPLACEMENT

TOOLS: 5/8 inch open end wrench

PARTS/MATERIALS: Engine Alarm Mute Switch

REMOVE:

NOTE

Port and starboard engine alarm mute switches are removed in the same manner.

1. Using 5/8 inch open end wrench loosen two nuts (4) to remove protective boot (5) on front of switch plate (6).
2. Pull switch (7) out from back of switch plate (6) until it is clear of plate opening.
3. Remove four leads (8) from four tabs (9) on back of switch (7).

REPLACE:

NOTE

Terminals are replaced with jumper on inside tab.

1. Install four leads (8) onto tabs (9) on back of switch (7).
2. Install switch (7) thru back of switch plate (6). Flats on nut (10) must be parallel to switch plate (6) for switch to be installed properly.
3. Install protective boots (5) over switch and tighten two nuts (4) using 5/8 inch open end wrench.

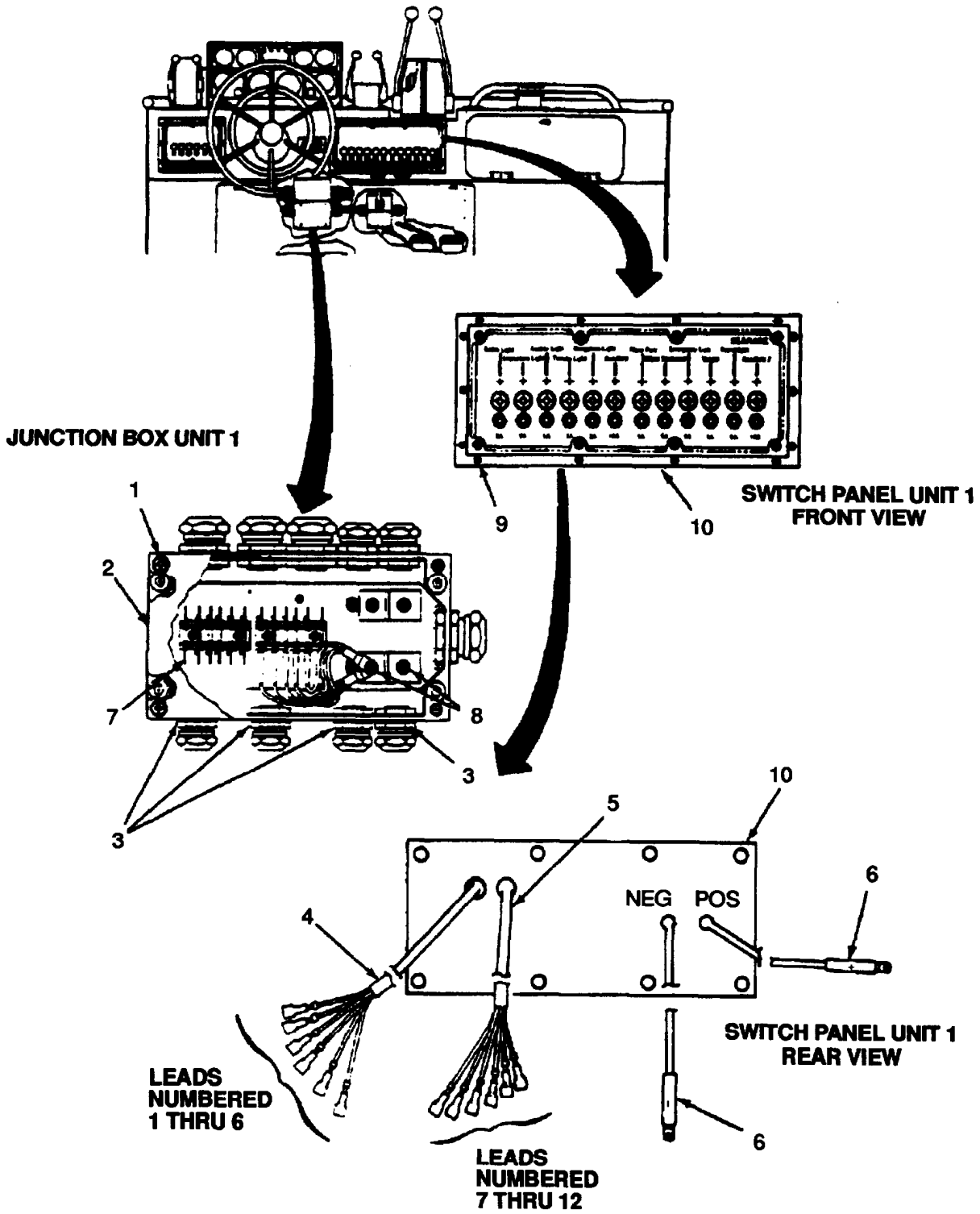

3-50. SWITCH PANEL UNIT #1 REPLACEMENT INSTRUCTIONS

TOOLS: 6 In. Crosstip Screwdriver, No. 2 Point
1 1/4 In. Open End Wrench
Nut Driver Set
Adjustable Wrench

PARTS/MATERIALS: Switch Panel Unit 1

REMOVE:

1. Switch master switch off (refer to paragraph 1-17).
2. Open access panel door under control console (refer to paragraph 3-154).
3. Using crosstip screwdriver, remove four screws (1) that secure junction box unit 1 cover to junction box (2) and remove cover.
4. At junction box unit 1, use open end wrench and adjustable wrench to loosen and unscrew cable gland hex nuts (3) where cable harnesses (4), (5) and power leads + and - (6) enters junction box.
5. Tag leads and receptacles. Remove switch panel unit 1 cable leads from quick disconnect receptacles (7).
6. Use nut driver to remove power leads + and - (6) from junction box unit 1 terminals (8).
7. Carefully pull switch panel unit 1 cable harnesses (4), (5) and power leads (6) from junction box unit 1 (2).
8. Using crosstip screwdriver, remove 14 screws (9) that secure switch panel unit 1 (10) to console.
9. Remove the switch panel with cable harnesses and power leads from console.

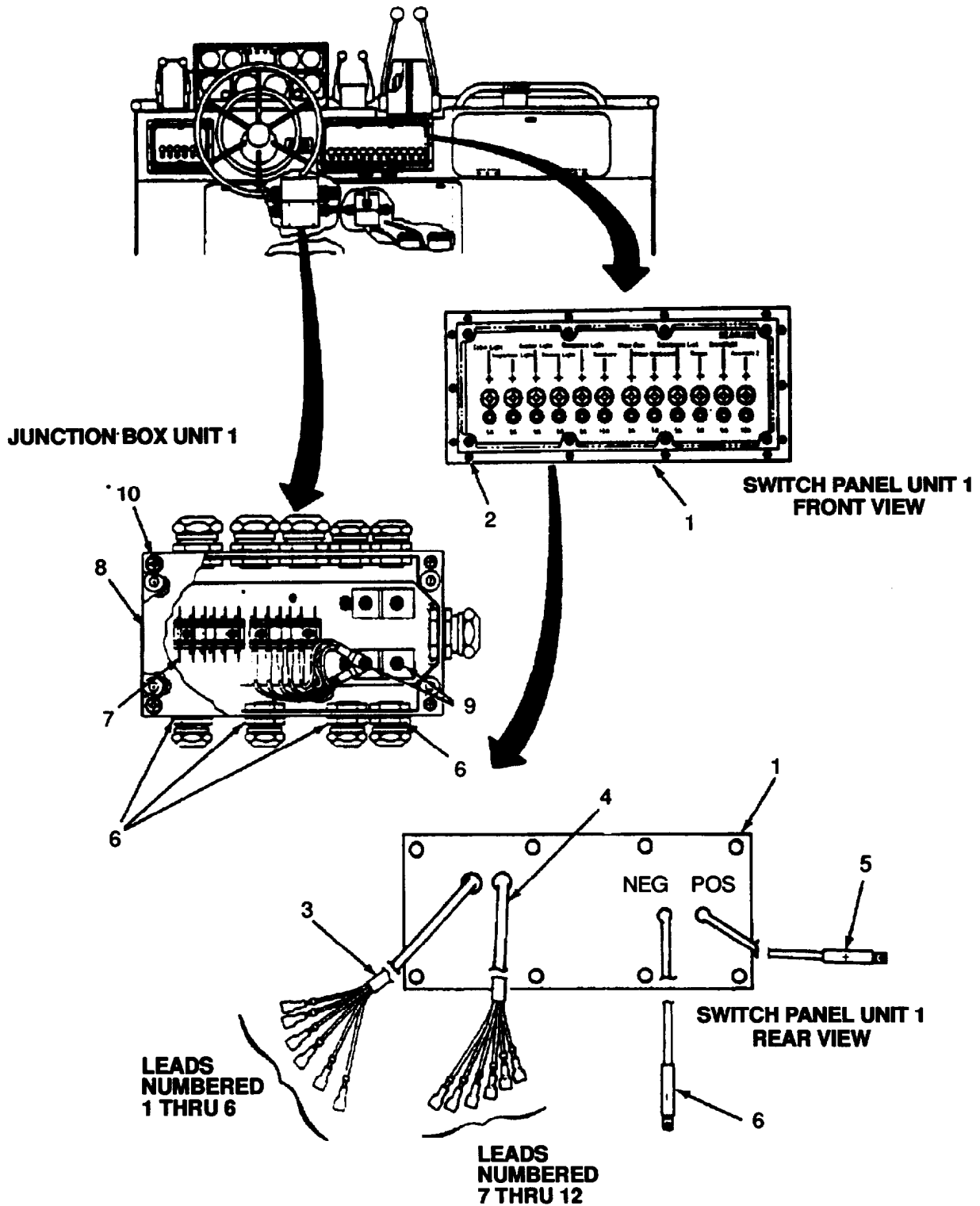

INSTALL

1. Route cable harnesses and power leads through console opening, align switch panel unit 1 (1) with mounting holes, and secure with 14 screws (2) using crosstip screwdriver.
2. Insert switch panel unit 1 cable harnesses (3), (4) and power leads + and - (5) through their respective cable glands (6).
3. Observe lead numbers and connect cable harnesses (3) and (4) leads to their respective tagged quick disconnect receptacles (7) in junction box unit 1 (8).
4. Connect power leads + and - (5) to respective terminals (9) in junction box unit 1 (8).
5. Use open end wrench and adjustable wrench to tighten cable gland hex nuts (6).

NOTE

Make sure junction box cover gasket and O-rings are not damaged. Replace damaged O-ring or gasket.

6. Install junction box cover and secure with four screws (10) using crosstip screwdriver.
7. Refer to paragraph 3-154 and dose access panel under control console if all task in this area are complete.

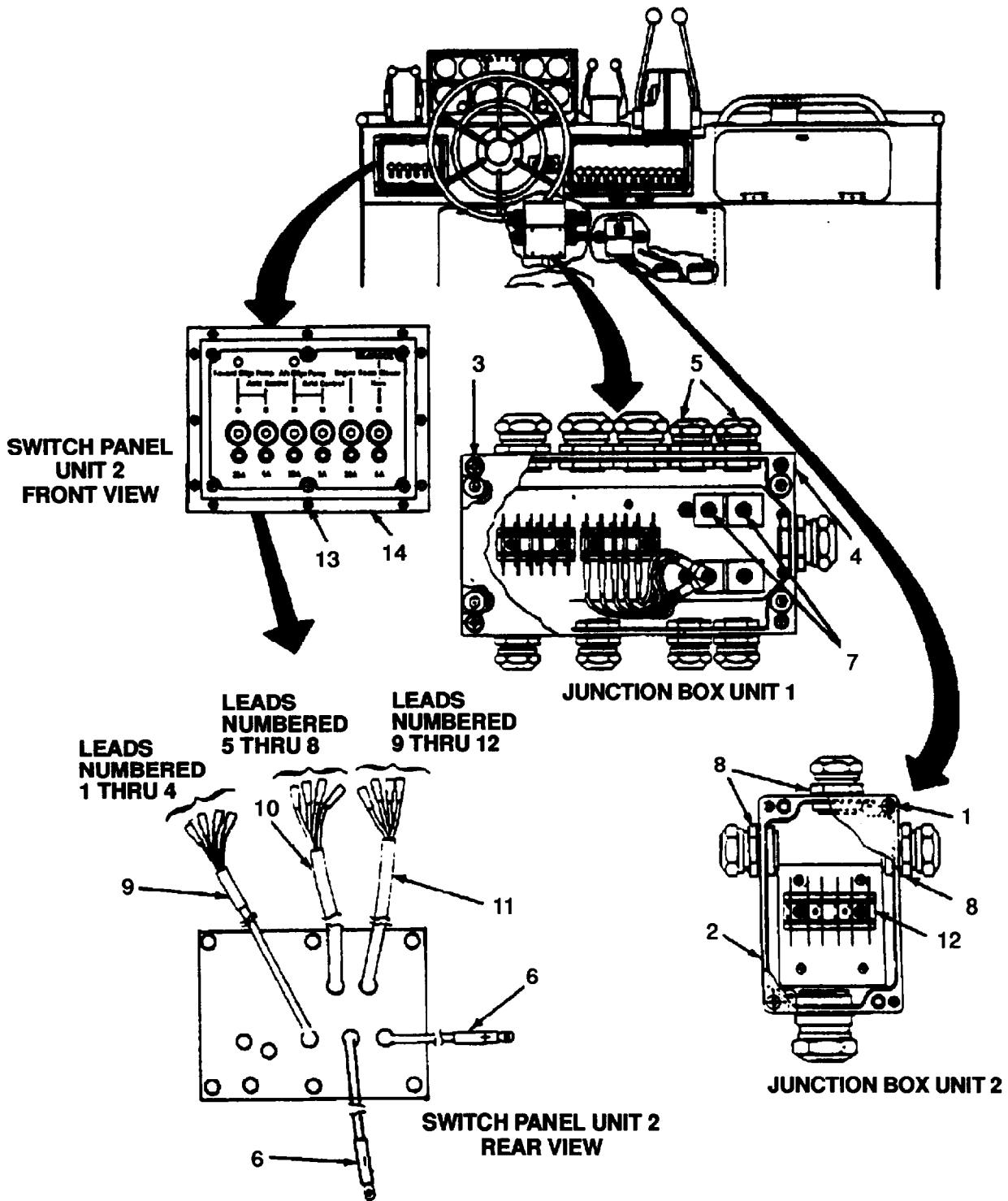

3-51. SWITCH PANEL UNIT #2 REPLACEMENT INSTRUCTIONS

TOOLS: 6 In. Crosstip Screwdriver
1/4 In. Open End Wrench
Adjustable Wrench
Nut Driver Set

PARTS/MATERIALS: Switch Panel Unit 2

REMOVE:

1. Switch master switch off (refer to paragraph 1-17).
2. Open access panel door under control console. (Refer to paragraph 3-154).
3. Using crosstip screwdriver, remove four screws (1) that secure junction box unit 2 cover to junction box (2) and remove the cover.
4. Using crosstip screwdriver, remove four screws (3) that secure junction box unit 1 cover to junction box (4) and remove the cover.
5. At junction box unit 1 (4), use open end wrench and adjustable wrench to loosen and unscrew cable glands (5) where + and - power leads (6) from switch panel unit 2 (14) enters junction box unit 1 (4).
6. Use nut driver to remove switch panel unit 2 (14) + and - power leads (6) from junction box terminals (7) then remove power leads from junction box unit 1 (4).
7. At junction box unit 2 (2) use open end wrench and adjustable wrench to loosen and unscrew cable glands (8) for cable harness (9), (10) and (11) then tag and disconnect all cable harness leads from quickdisconnect receptacles (12).
8. Pull cable harnesses from junction box unit 2 (2).
9. Using crosstip screwdriver, remove 12 screws (13) that secure switch panel unit 2 (14) to console.
10. Remove switch panel unit 2 (14) with cable harnesses and power leads from console opening.

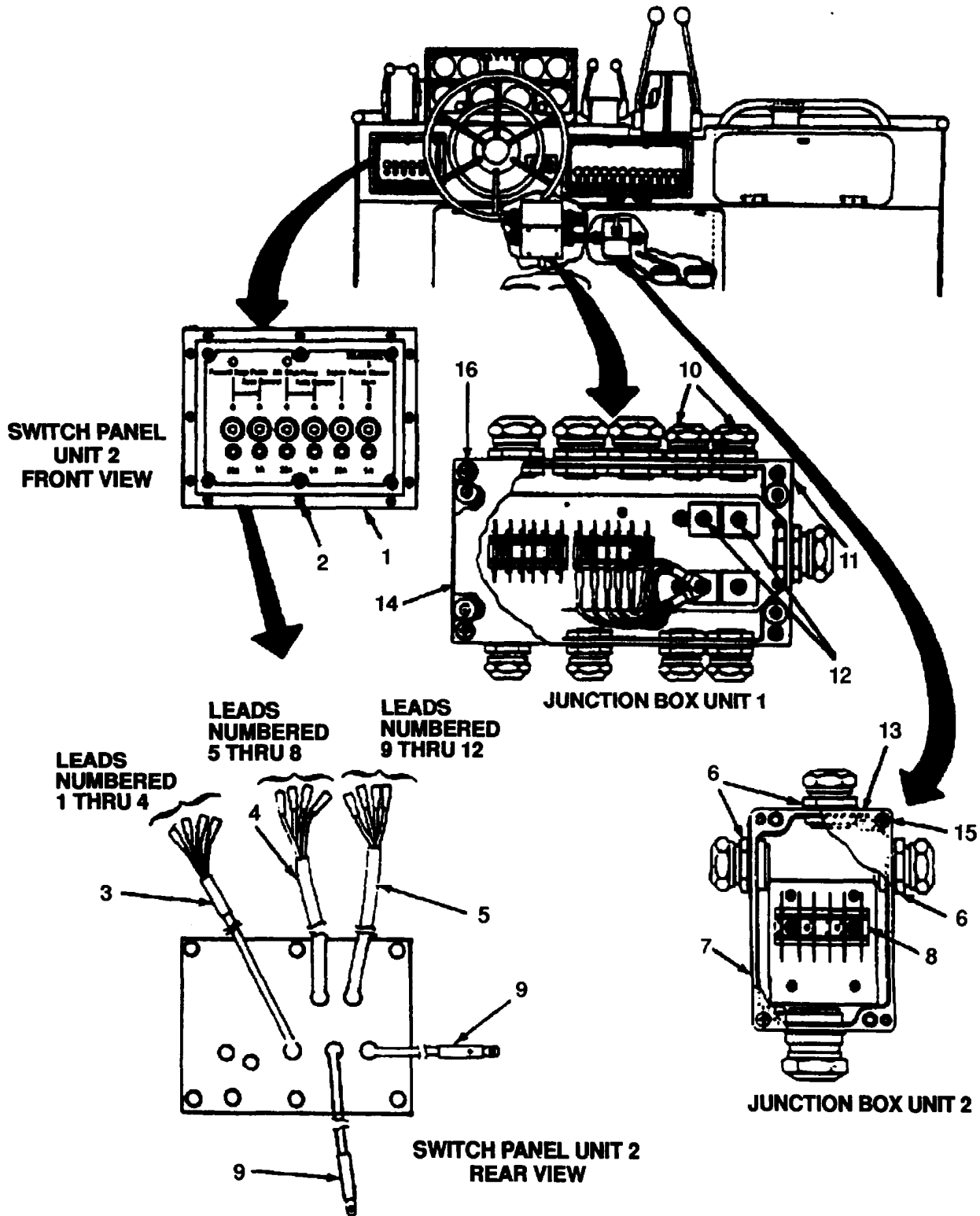

INSTALL:

1. Route cable harnesses and power leads through console opening, align switch panel unit 2 (1) with mounting holes, and secure with 12 screws (2) using crosstip screwdriver.
2. Insert switch panel unit 2 cable harnesses (3), (4) and (5) through cable glands (6) on junction box unit 2 (7).
3. Observing lead numbers, connect cable harnesses leads (3), (4) and (5) to respective tagged quick disconnect receptacles (8) in junction box unit 2 (7).
4. Insert power leads + and - (9) through cable glands (10) on junction box unit 1 (11) and connect power leads (9) to terminals (12).
5. Use open end wrench and adjustable wrench to tighten cable gland hex nuts (6) and (10) on junction boxes as indicated.

NOTE

Make sure junction box cover gaskets and o-rings are not damaged. Replace damaged o-ring or gasket.

6. Install junction box cover (13) and (14) and secure with four screws (15) and (16) on each junction box using crosstip screwdriver.
7. Refer to paragraph 3-154 and dose access panel under control console.

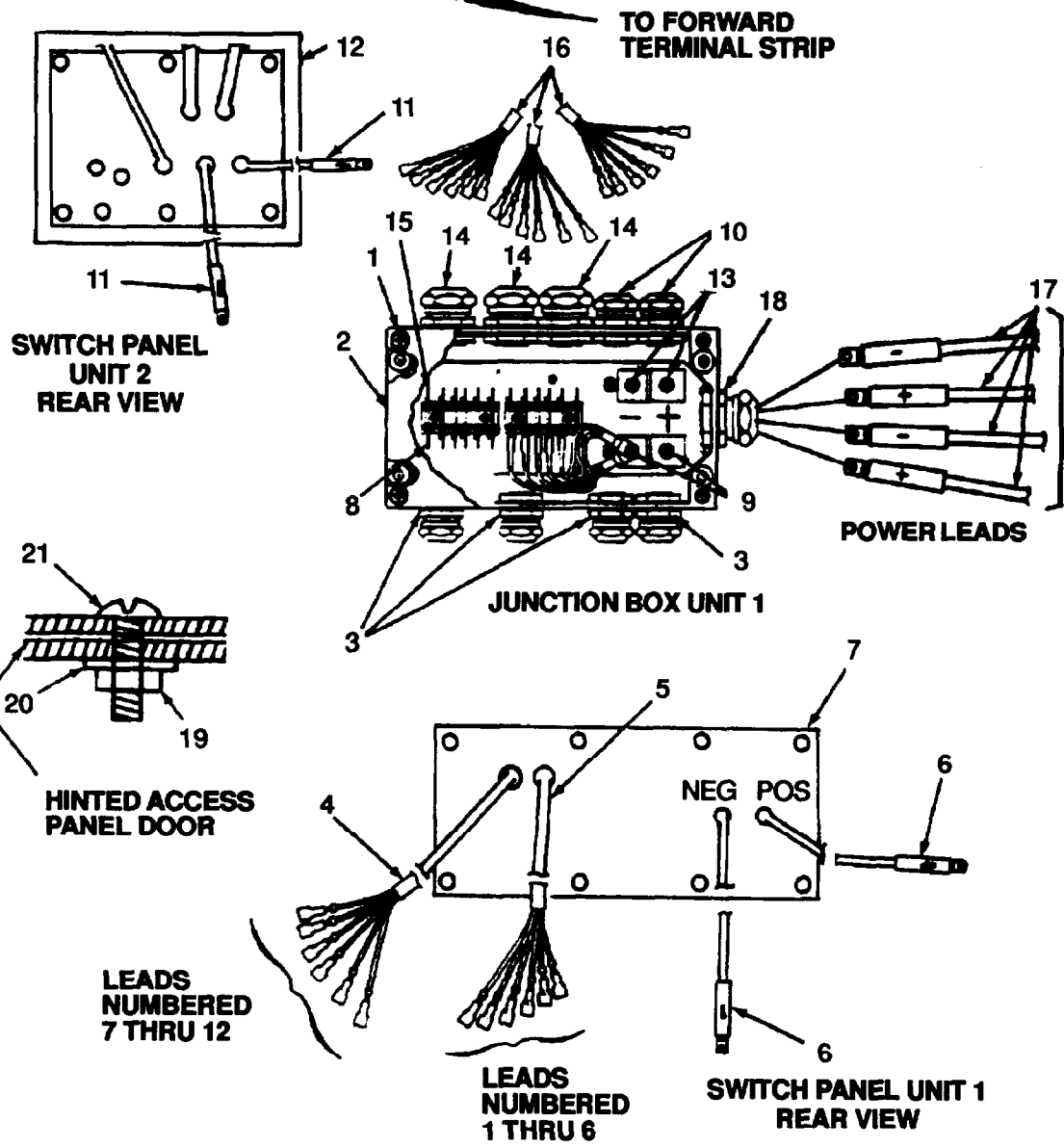
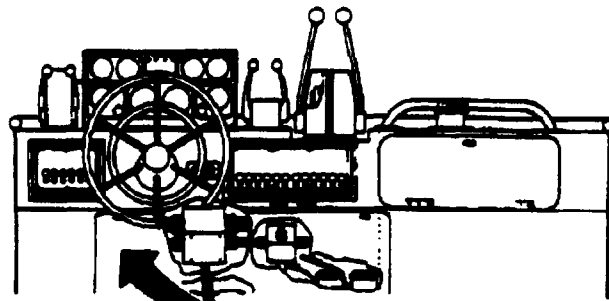

3-52. JUNCTION BOX UNIT 1 REPLACEMENT INSTRUCTIONS

TOOLS: 6 In. Crosstip Screwdriver
1 1/4 In. Open End Wrench
Adjustable Wrench
Nut Driver Set

PARTS/MATERIALS: Junction Box Unit 1

REMOVE

1. Switch master switch off (refer to paragraph 1-17).
2. Open access panel under control console. (Refer to paragraph 3-154).
3. Using crosstip screwdriver, remove four screws (1) that secures junction box unit 1 cover to junction box (2) and remove cover.
4. At junction box unit 1 (2), use open end wrench and adjustable wrench to loosen and unscrew cable gland hex nuts (3) where cable harnesses (4), (5), and power leads + and - (6) enters junction box unit 1 (2).
5. Tag and remove switch panel unit 1 (7) cable leads (4) and (5) from quick disconnect receptacles (8).
6. Use nut driver to remove power leads + and - (6) from junction box terminals (9).
7. Carefully pull switch panel unit 1 (7) cable harnesses and power leads (6) from junction box unit 1 (2).
8. Use open end wrench and adjustable wrench to loosen and unscrew cable glands (10) where + and - power leads (11) from switch panel unit 2 (12) enters junction box unit 1 (2).
9. Use nut driver to remove switch panel unit 2 (12) + and - power leads (11) from junction box terminals (13) then remove power leads from junction box unit 1 (2).
10. Label and disconnect three wiring harnesses (14) from quick disconnect receptacles (15).
11. Use open end wrenches to loosen and remove hex nuts from cable harness glands (14) and tag and remove cable harnesses (16) from junction box unit 1 (2).
12. Label and disconnect four power leads (17) from terminals (13) and (9) in junction box unit 1 (2).
13. Using open end wrench and adjustable wrench to loosen and unscrew gland nut (18) where power leads (17) enters junction box unit 1 (2).
14. Carefully remove power leads (17) from junction box unit 1 (2).
15. Using a boxed end wrench and crosstip screwdriver, remove four nuts (19), washers (20), and screws (21) that secure junction box unit 1 (2) to hinged access panel.
16. Remove junction box unit 1 (2) from hinged access panel.

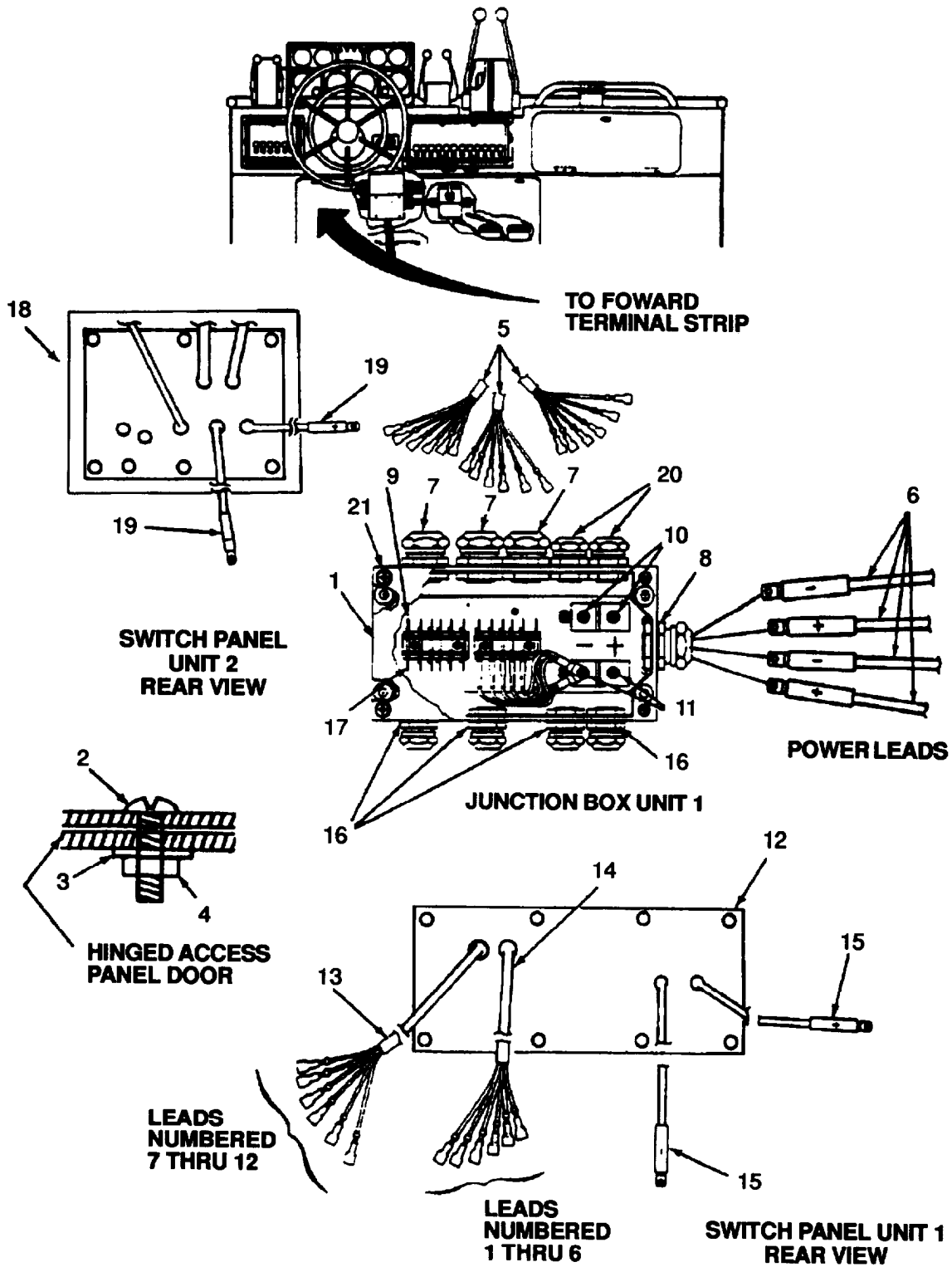

INSTALL:

1. Aline junction box unit 1 (1) with four mounting holes in access panel and secure with four screws (2) washers (3) and nuts (4).
2. Insert three wiring harnesses (5) and power leads through their respective cable glands (7) and (8) on junction box unit 1 (1).
3. Observe labels and connect wiring harnesses (5) to quick disconnect receptacles (9), then tighten hex nuts on cable glands (7).
4. Observe labels and connect power leads + and - (6) to terminals (10) and (11) on junction box unit 1 (1), then tighten hex nuts on cable glands (8).
5. Insert switch panel unit 1 (12) cable harnesses (13) and (14) and power leads + and - (15) through their respective cable glands (16).
6. Observe lead numbers and connect cable harnesses (13) and (14) leads to their respective tagged quick disconnect receptacles (17) and connect power leads + and - (15) to terminals (11) in junction box unit 1 (1).
7. Insert switch panel unit 2 (18) power leads + and - (19) through their respective cable glands (20), and connect power leads + and - (19) to their respective terminal (10).
8. Use open end wrench and adjustable wrench to tighten cable gland hex nuts (16) and (20).

NOTE

Make sure junction box cover gasket and o-rings are not damaged. Replace damaged o-ring or gasket.

9. Install junction box cover and secure with four screws (21) using crosstip screwdriver.
10. Refer to paragraph 3-154 and dose access panel under control console.

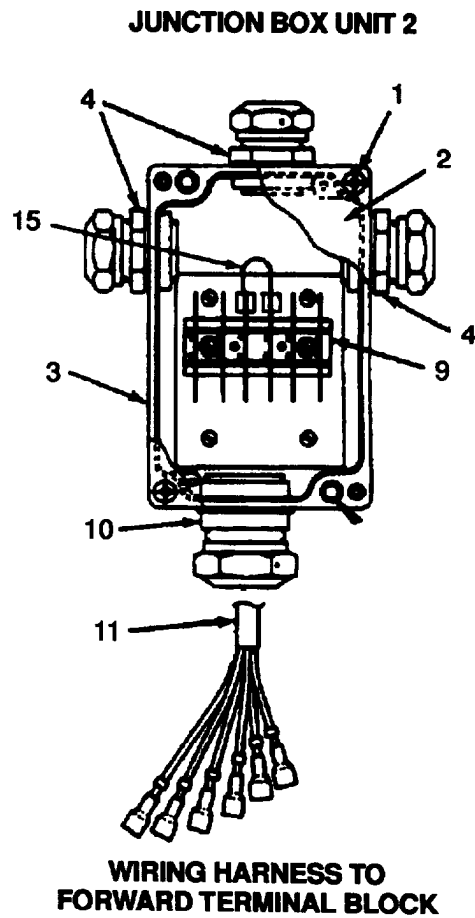
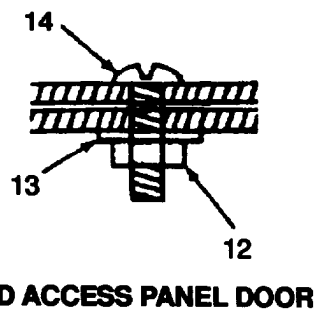
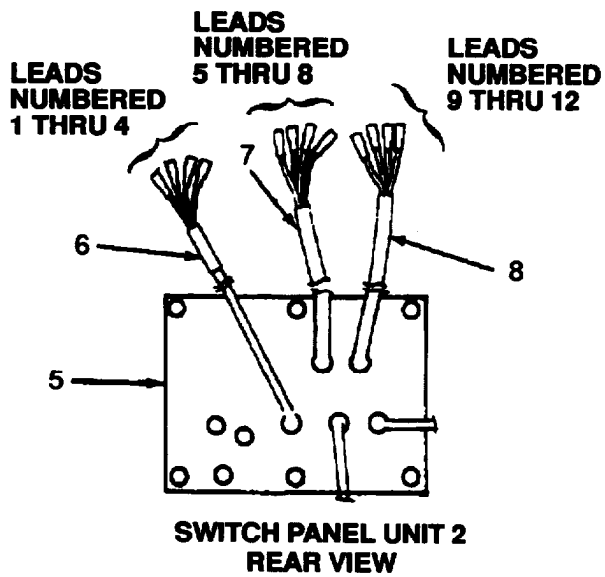
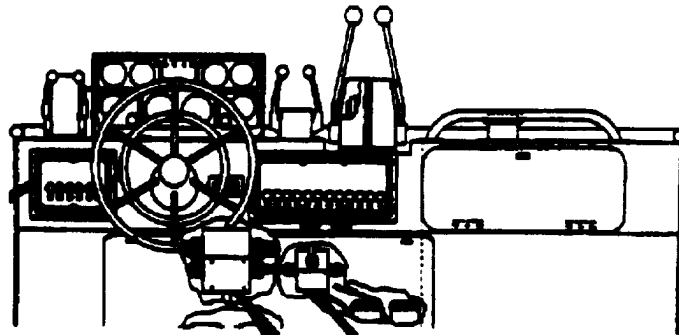

3-53. JUNCTION BOX UNIT 2 REPLACEMENT INSTRUCTIONS

TOOLS: 6 In. Crosstip Screwdriver
1 1/4 In. Open End Wrench
Adjustable Wrench
Nut Driver Set

PARTS/MATERIALS: Junction Box Unit 2

REMOVE

1. Switch master switch off (refer to paragraph 1-17).
2. Open access panel under control console. (Refer to paragraph 3-154).
3. Using crosstip screwdriver, remove four screws (1) that secures junction box unit 2 cover (2) to junction box unit 2 (3) and remove the cover.
4. At junction box unit 2 (3) use open end wrench and adjustable wrench to loosen and unscrew cable glands (4) where switch panel unit 2 (5) wiring harness leads (6), (7), and (8) enters junction box unit 2 (3).
5. Tag and disconnect switch panel unit 2 (5) wiring harness lead (6), (7), and (8) from quick disconnect receptacles (9) in junction box unit 2 (3).
6. Tag and carefully pull switch panel unit 2 (5) wiring harness leads (6), (7), and (8) from junction box unit 2 (3).
7. Use open end wrench and adjustable wrench to loosen and unscrew cable gland hex nuts (10) where wiring harness (11) to forward terminal block enters junction box unit 2 (3).
8. Tag and disconnect wiring harness leads (11) from quick disconnect receptacles (9) in junction box unit 2 (3).
9. Tag and carefully remove the forward terminal block wiring harness leads (11) from junction box unit 2 (3).
10. Using box end wrench and crosstip screwdriver, remove two nuts (12), washers (13), and screws (14), that secures junction box unit 2 (3) to access panel door.
11. Remove junction box unit 2 (3) from hinged access panel.
12. Disconnect and remove the two jumper leads (15) from quick disconnect receptacle terminal pairs 9-10 and 11-12 and retain jumper leads for installation of new junction box unit 2.

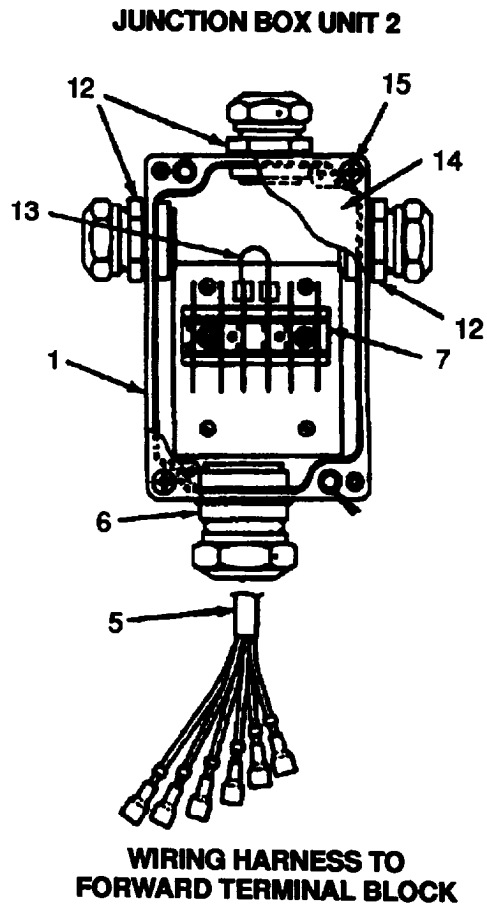
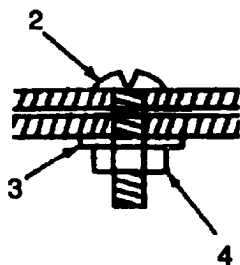
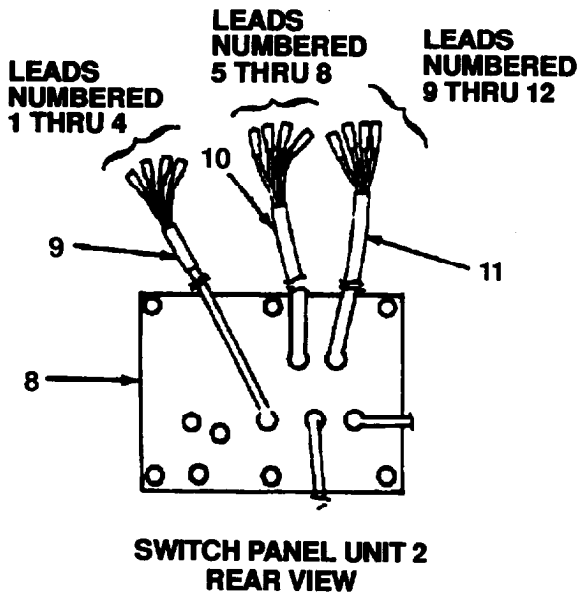
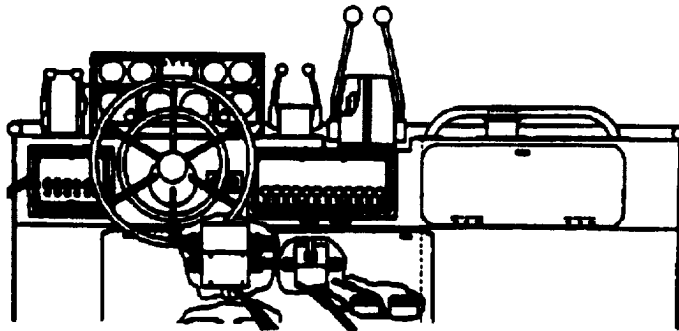

INSTALL:

1. Aline junction box unit 2 (1) with mounting holes in access panel and secure with two screws (2), washers (3) and nuts (4).
2. Insert wiring harness (5) through cable harness gland (6).

NOTE

Observe numbered connectors to insure correct connections are made.

3. Connect wiring harness (5) to quick disconnect receptacles (7) and tighten cable gland hex nuts (6).
4. Insert switch panel unit 2 (8) cable harnesses (9), (10), and (11) through cable glands (12) on junction box unit 2 (1).
5. Observing lead numbers, connect cable harness leads to respective tagged quick disconnect receptacles (7) in junction box unit 2 (1).
6. Use open end wrench and adjustable wrench to tighten cable gland hex nuts (12) on junction box unit 2 (1) as indicated.

NOTE

Make sure junction cover gaskets and o-rings are not damaged. Replace damaged o-ring or gasket.

7. Connect the two jumper leads (13) to quick dined receptacles - terminal pairs 9-10 and 11-12.
8. Using crosstip screwdriver, secure junction box cover (14) with four screws (15) to junction box unit 2 (1).
9. Refer to paragraph 3-154 and dose hinged access panel under control console.

SWITCH PANEL UNIT 1; REAR COVER; INSIDE VIEW

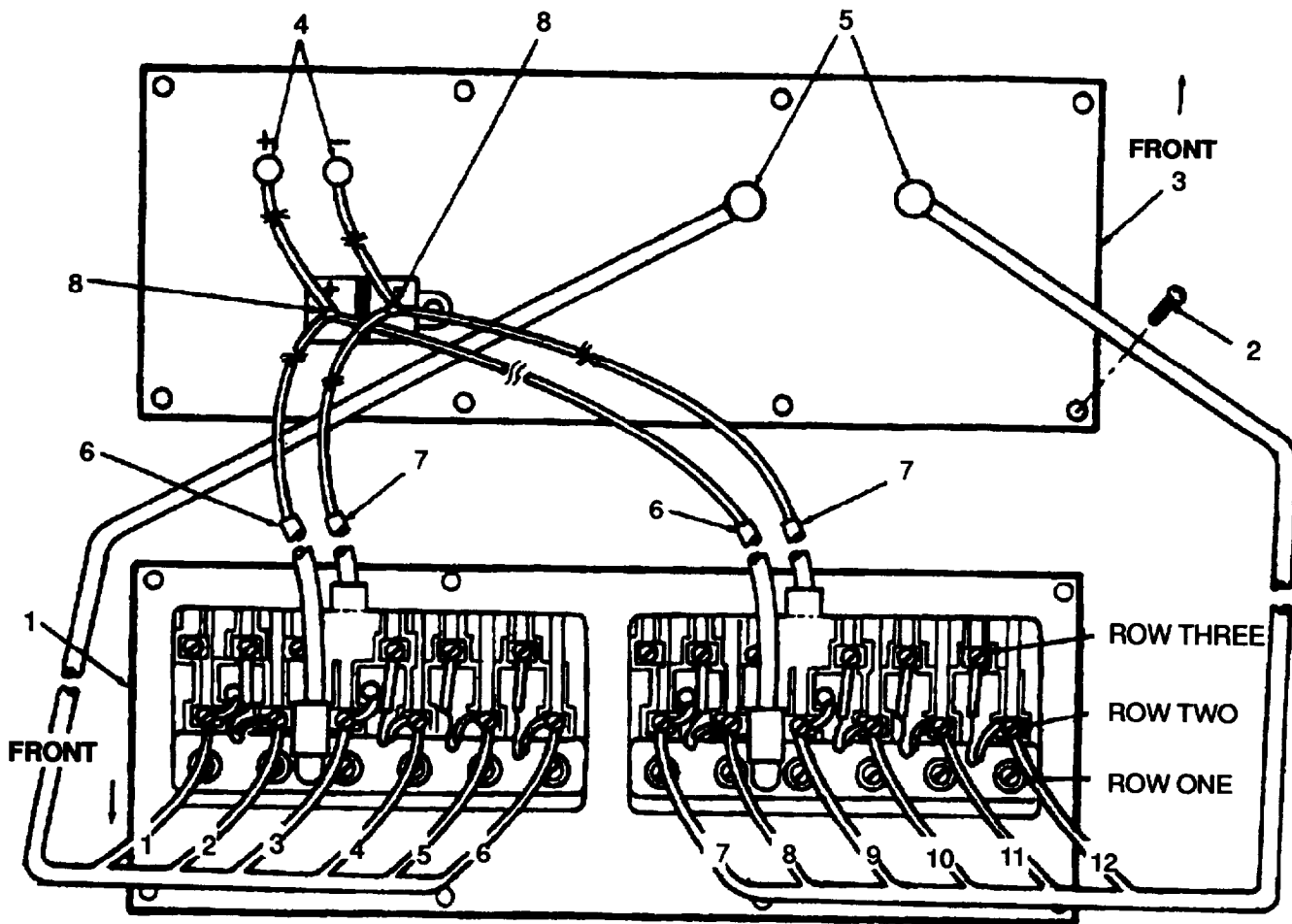

SWITCH PANEL UNIT; REAR VIEW; WITH REAR COVER REMOVED

Wiring Harnesses and Power Leads Switch Panel Unit 1

3-54. SWITCH PANEL UNIT #1 TO JUNCTION BOX UNIT 1 WIRING HARNESSSES

REPLACEMENT AND TEST INSTRUCTIONS

TOOLS: Multimeter URM 105

- 6 In. Crosstip Screwdriver
- 1 1/4 In. Open End Wrench
- Adjustable Wrench
- Nut Driver Set

PARTS/MATERIALS: Cable Harnesses and + and - Power Leads

REMOVE:

1. Refer to paragraph 1-17 and remove power from circuit.
2. Refer to paragraph 3-50 and remove switch panel unit 1 (1) with cable harnesses and power leads from control console.
3. Using crosstip screwdriver, remove eight screws (2) that secures rear cover (3) to switch panel and separate rear cover from switch panel unit 1 (1).
4. Using open end wrench and adjustable wrench loosen and unscrew hex nuts from cable glands (4) and (5) from rear cover (3).
5. Tag and using flat tip screwdriver disconnect leads from switch terminals row two and carefully remove leads from rear cover (3) of panel through cable glands (5).
6. Tag and using box-end wrench disconnect + (6) and - (7) leads from terminals (8) on rear cover (3). Remove leads from rear cover (3) of panel through cable glands (4).

TEST

1. Refer to paragraph 3-153 and set multimeter for Ohms and test all wiring harness leads and power leads for continuity.

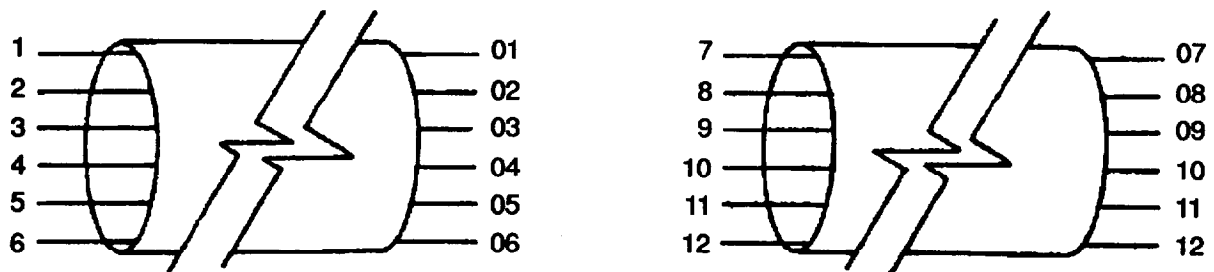

2. If continuity test fails, replace wiring harness with a serviceable wiring harness.

SWITCH PANEL UNIT 1; REAR COVER; INSIDE VIEW

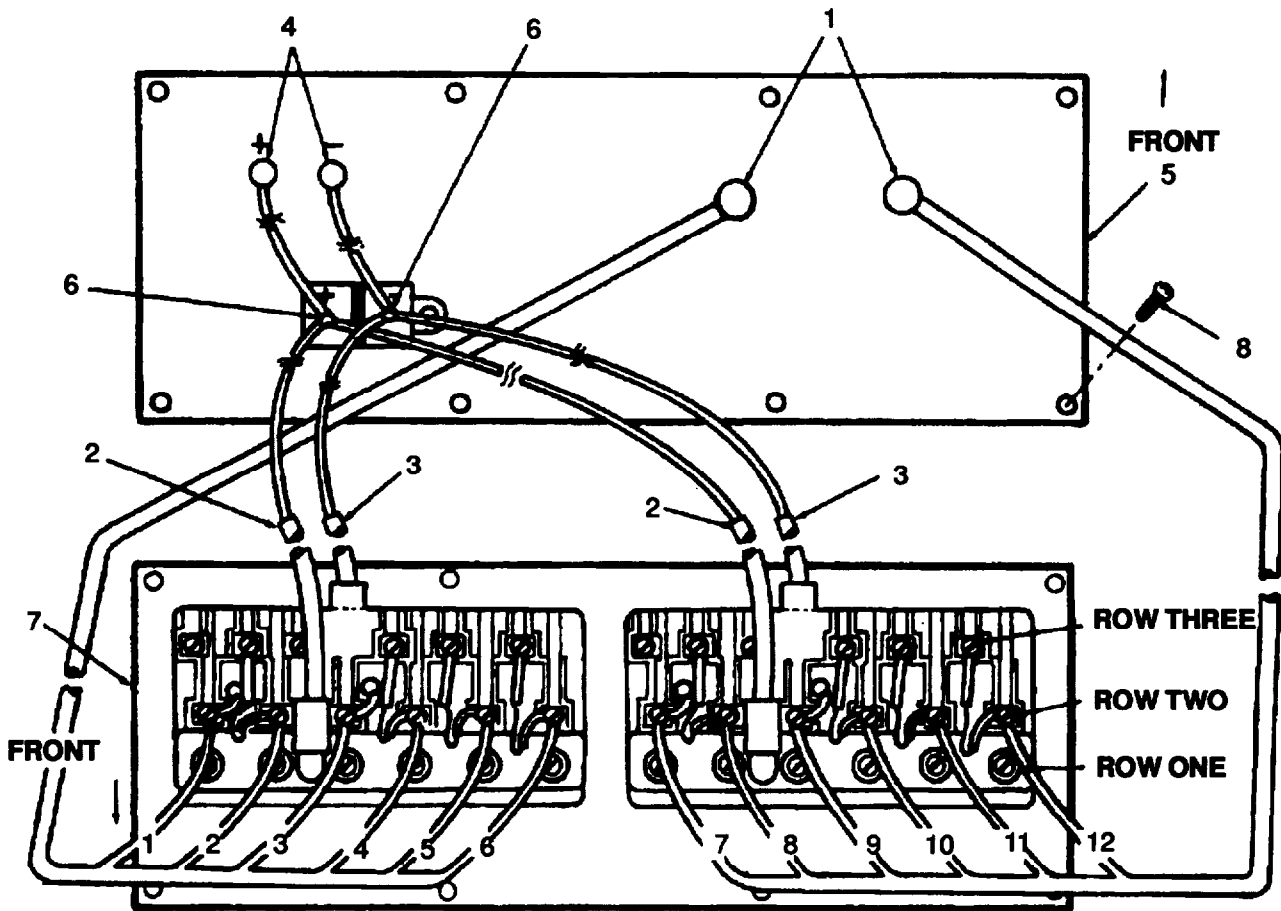

SWITCH PANEL UNIT; REAR VIEW; WITH REAR COVER REMOVED

Wiring Harnesses and Power Leads Switch Panel Unit 1

INSTALL:

1. Tag leads on new harnesses and power leads to match the tags on harnesses and power leads removed.
2. Insert wiring harness leads through cable glands (1) and connect leads to terminals row two as tagged, matching cables as shown on paragraph 3-54.
3. Insert + (2) and - (3) power leads through cable glands (4) on rear cover (5) and connect + (2) and - (3) leads to terminals (6) and tighten hex nuts on terminals.
4. Secure and tighten cable gland hex nuts (4) and (1) with open end wrench.
5. Secure rear cover (5) to switch panel unit 1 (7) with eight screws (8).
6. Refer to paragraph 3-50 and install switch panel unit 1 to console.

3-55. HORN REPLACEMENT INSTRUCTIONS

TOOLS: Fiat lip Screwdriver
11 mm Open End Wrench

PARTS/MATERIALS: Horn

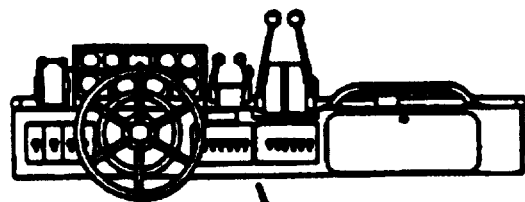

MK-1

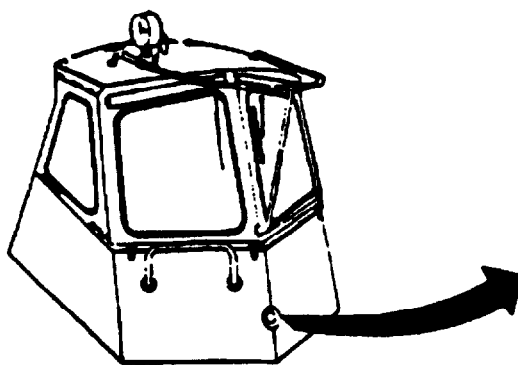
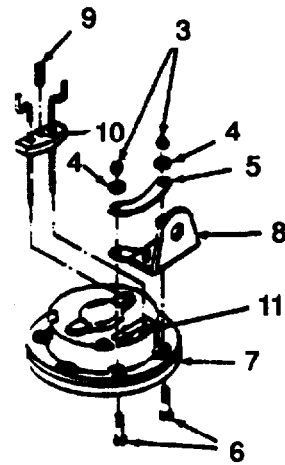
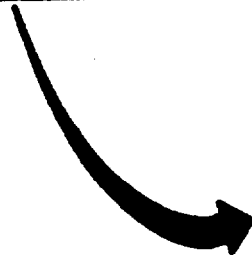

MK-2

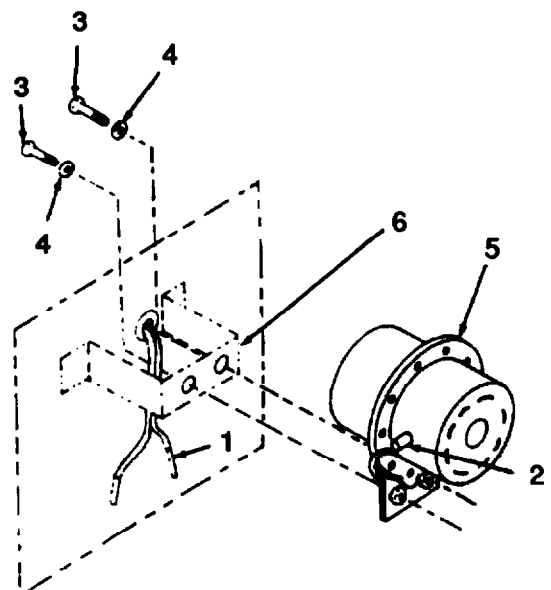

REMOVE:

1. On MK1, open control console access hatch (refer to paragraph 3-154).

NOTE

Hold horn during removal process to prevent falling.

2. Loosen and remove two nuts (3), washers (4), spacer (5), and bolts (6) which retain horn (7) on bracket (8) using wrench and screwdriver.
3. Loosen and remove center screw (9) from horn using screwdriver.
4. Carefully pry electrical connector (10) from receptacle (11) with screwdriver.
5. Remove horn (7).
6. On MK2, disconnect electrical leads (1) from horn connections (2).
7. Using wrench, remove two bolts (3), two washers (4) and horn (5) from retaining bracket (6).

INSTALL:

1. On MK1, hold horn (7) and insert electrical connector (10) into receptacle (11). Align center screw (9) and tighten using screwdriver.
2. Install two bolts (6) thru horn body (7) thru bracket (8) and spacer (5).
3. Install washers (4), nuts (3) and tighten using wrench and screwdriver.
4. Close control console access hatch (refer to paragraph 3-154).
5. On MK2, align horn bracket bolts with retaining bracket holes and secure with bolts (3) and washers (4).
6. Connect electrical leads (1) to horn connectors (2).

3-56. ENGINE AUDIBLE ALARM REPLACEMENT

TOOLS: 5/16 inch Open End Wrench
1/4 inch Flat lip Screwdriver
1/8 inch Flat lip Screwdriver
Pliers, Side Cutter

PARTS/MATERIALS: Engine Audible Alarm

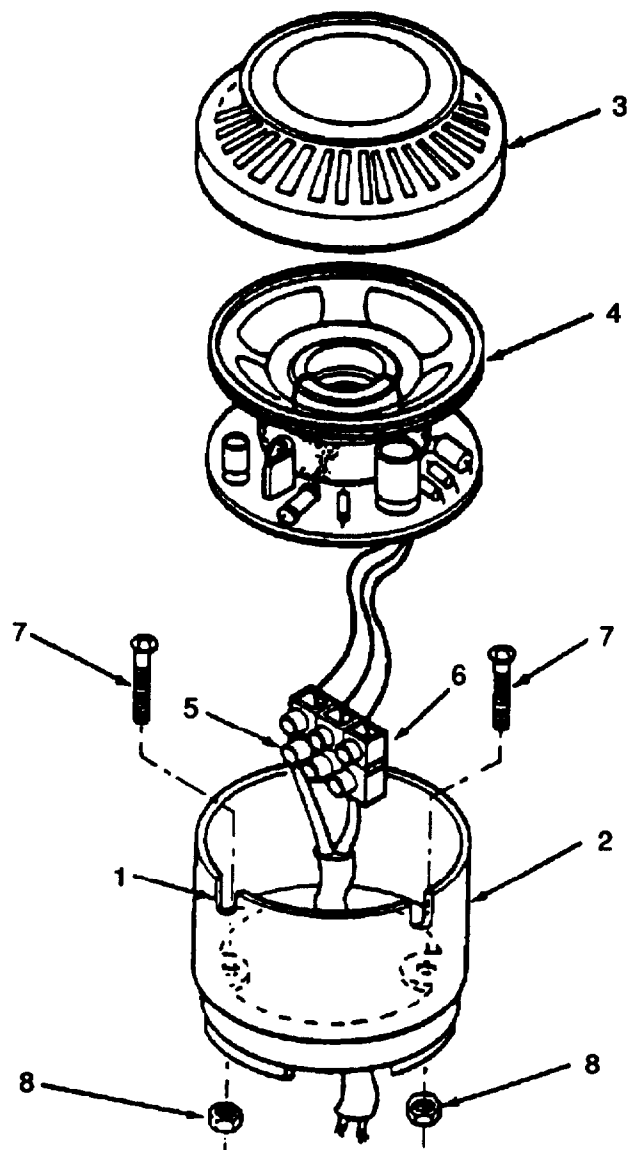

REMOVE:

1. Open control console access hatch (refer to paragraph 3-154).
2. Fit 1/8 inch screwdriver into slot (1) in alarm body (2).
3. Gently pry cap (3) off body.



All wires are still connected. Do not pull element out with jerk. It will break wires.

4. Using fingers, lift alarm element (4) out of body (2).
5. Using 1/8 inch screwdriver, loosen three screws (5) holding element lead wires to terminal block (6).
6. Pull wires out of terminal block and set element aside.
7. Using 1/4 inch screwdriver and wrench, remove the two screws (7) and nuts (6) that hold body to console.
8. Retain screws and nuts for use with new alarm.
9. Dispose of old body, element and cap.

INSTALL:

1. Fit 1/8 inch screwdriver into slot (1) of new alarm body (2).
2. Gently pry cap (3) off body.
3. Using fingers, lift alarm element (4) out of body (2).
4. Cut alarm element (4) lead wires to 4 inches (100 mm) length.
5. Strip about 1/4 inch of insulation from each lead wire.
6. Feed terminal block (6) and connected wires through bottom of new alarm body (2).
7. Connect alarm element (4) lead wires to terminal block (6).

Red to Red.
Black to Black
Yellow to Center.

8. Using 1/8 inch screwdriver, tighten three screws (5) to hold alarm element lead wires to terminal block (6).

NOTE

Alarm element is out of body for next step.

9. Put two screws (7) into holes in bottom of alarm body (2).
10. Position alarm body (2) in console with screws through holes available.
11. Using 1/4 inch screwdriver, hold screws and put nuts (8) on with fingers. Do not tighten.
12. Position alarm feed wires in one of the gaps in alarm body bottom.

NOTE

Do not allow alarm element to hang up during next step. Element lead wires will be pulled loose or broken

13. Pull alarm feed wires until terminal block (6) is at bottom of alarm body (2).
14. Using 1/4 inch screwdriver and wrench, tighten two screws (7) and nuts (8).
15. Carefully fit alarm element (4) into alarm body (2).
16. Fit cap (3) onto body.
17. Press cap (3) until it snaps in place.
18. Check alarm function (refer to TM 5-1940-277-10).
19. Close console access hatch (refer to paragraph 3-154).

3-57. FUEL TUBING REPLACEMENT INSTRUCTIONS

TOOLS: 7/16 inch Open End Wrench
5/8 inch Open End Wrench
Tubing Cutter

PARTS / MATERIALS :

Tubing Nut
Tubing Sleeve
Plastic Ties
Liquid Measure, Two Quart Capacity

REMOVE:

1. Open and secure battery hatch (refer to paragraph 3-154).
2. Open and secure engine hatches (refer to paragraph 3-154).

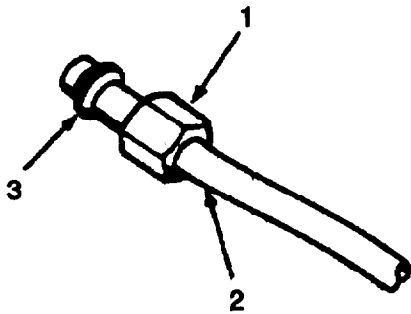

TUBE & FITTING TYPICAL

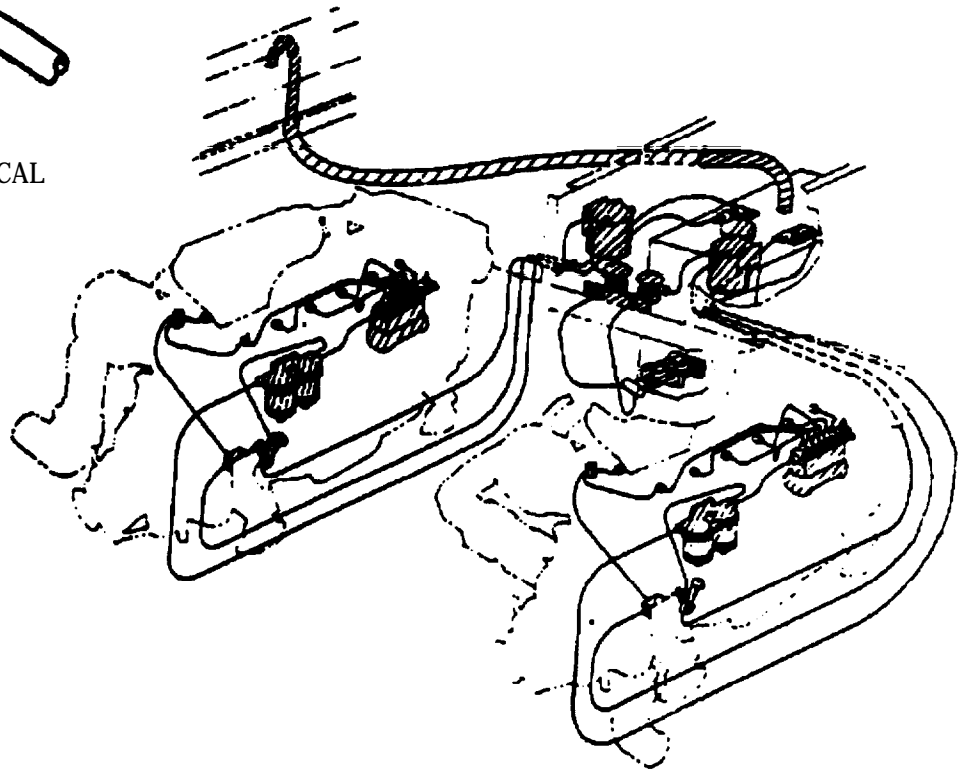

NOTE

- Remove tubing by section only as required.
 - Use two quart liquid measure to collect fuel trapped in tubing.
3. Place two quart liquid measure under fitting where tubing is to be disconnected.
 4. Use 5/8 inch open end wrench to loosen tubing nut
 5. Remove nut and drain tubing.
 6. Repeat steps 4 thru 6 for fitting at other end of tubing.
 7. Use 7/16 inch open end wrench to loosen tubing nut on fuel return tubing.

REPLACE:

NOTE

Tubing is not precut. Measure and cut tubing to length of tubing being replaced.

1. Use tubing cutter to cut tubing.
2. Put tubing nut (1) on tubing (2).
3. Put tubing sleeve (3) about 1/2 inch from end of tubing.
4. Install end of tubing in fitting, seat tubing firmly.
5. Slide tubing nut (1) down on tubing sleeve (3) fitting.
6. Start tubing nut on fitting by hand, turn until hand tight.

NOTE

When tubing nut is tightened with wrench it seats the tubing sleeve.

7. Use 5/8 inch open end wrench to tighten tubing nut on fuel supply tubing.
8. Use 7/16 inch open end wrench to tighten tubing nut on fuel return tubing.
9. Bleed fuel system (refer to paragraph 3-65).
10. Close engine hatches.
11. Close battery hatch.

3-58. ENGINE FUEL SHUTOFF VALVE AND DIAPHRAM REPLACEMENT

TOOLS: 5/16 inch Open End Wrench
1/4 inch Flat Tip Screwdriver
1/8 inch Flat Tip Screwdriver
Pliers, Side Cutter

PARTS/MATERIALS: Fuel Shutoff Valve Diaphragm
Container, One Quart Capacity
Pipe Taps

REMOVE:

1. Open and secure battery hatch (refer to paragraph 3-154).
2. Open and secure engine hatches (refer to paragraph 3-154).
3. Close fuel master shutoff valve (1).

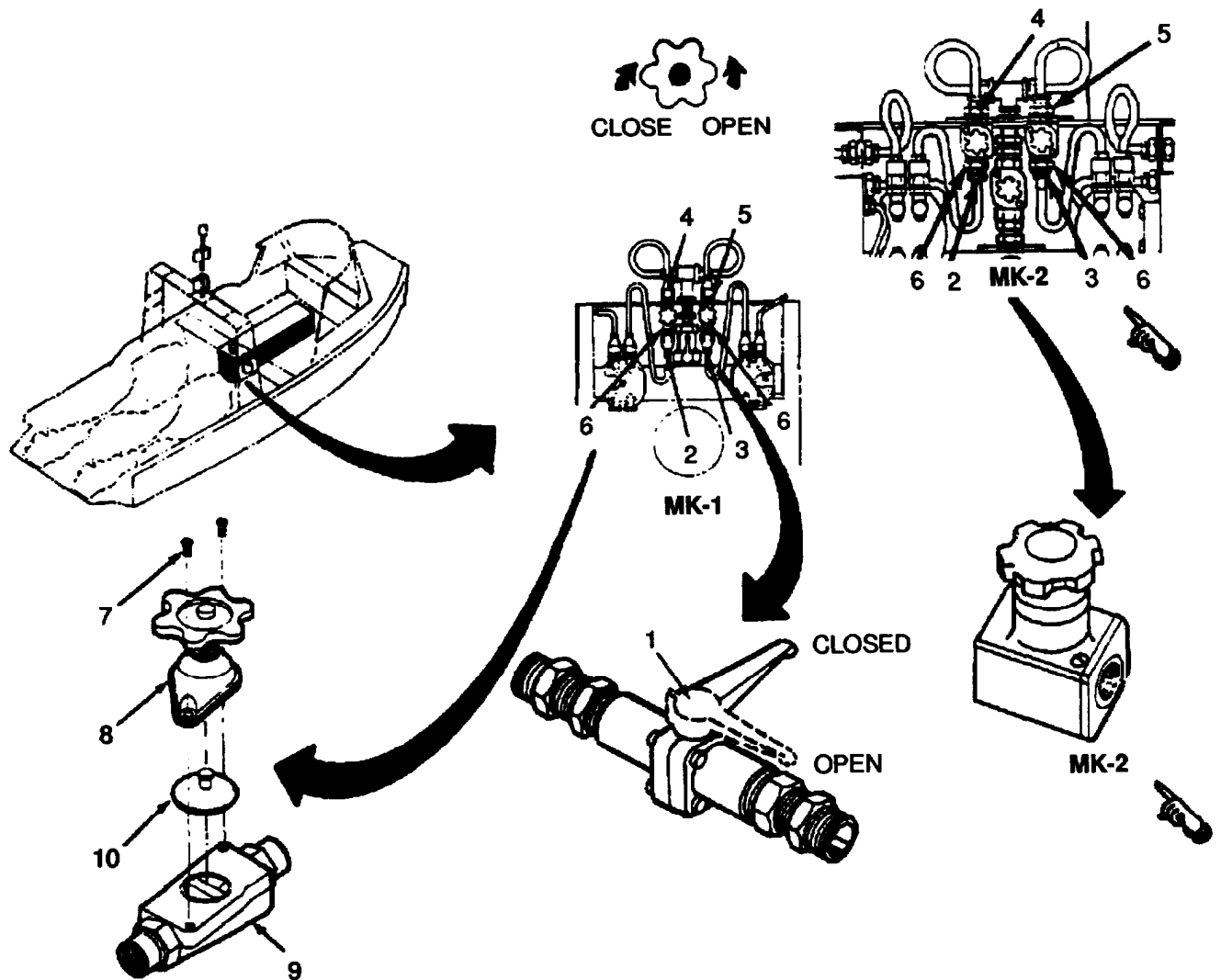

NOTE

If only diaphragm is to be replaced perform steps 8 thru 11 under removal and steps 1 thru 3 and 7 thru 10 under installation.

If complete valve is to be replaced perform steps 1 thru 7 under removal and steps 4 thru 8 under installation.

4. Disconnect engine valve inlet line (2 or 3) from engine fuel valve using 5/8 inch wrench. Catch fuel drain in container.
5. Disconnect engine fuel valve outlet line (4 or 5) to fuel water separator using 5/8 inch wrench. Catch fuel drain in container.
6. Using 15/16 inch wrench remove fitting (6) that secures valve to bulkhead.
7. Wipe up spilled fuel.
8. Using screwdriver remove two screws (7) securing valve cap (8) to valve body (9).
9. Remove valve cap (8) from valve body (9) to expose diaphragm (10).
10. Screw valve handle in to loosen diaphragm clamp.
11. Remove diaphragm (10) by pulling from cap (8) and clean mounting surfaces of valve body (9).

INSTALL:

1. Install replacement diaphragm (10) on valve cap (8) and screw handle out.
2. Fit valve cap (8) to valve body (9).
3. Install two screws (7) and tighten with screwdriver.
4. Using 15/16 inch wrench install fitting (6) to valve body securing valve to bulkhead. Coat fitting threads with pipe tape and install fitting to valve body (9) securing valve to bulkhead.
5. Connect engine fuel valve outlet lines (4 or 5) and fuel valve inlet lines (2 or 3) to valve body (9).
6. Tighten inlet and outlet lines [(2 and 4) or (3 and 5)] using 5/8 inch wrench.
7. Insure fuel valve is open.
8. Open master fuel shutoff valve (1).
9. Bleed fuel system (refer to paragraph 3-64).
10. Close engine and battery hatches.

3-59. FUEL MASTER SHUTOFF VALVE REPLACEMENT INSTRUCTIONS

TOOLS: 16 mm Open End Wrench
1-1/4 inch Open End Wrench
1-1/16 inch Open End Wrench
Dispensing Pump, Hand Driven

PARTS/MATERIALS: Master Shutoff Valve
Pipe Tape
Liquid Measure, Two Quart Capacity
Two Drums, Gallon Capacity

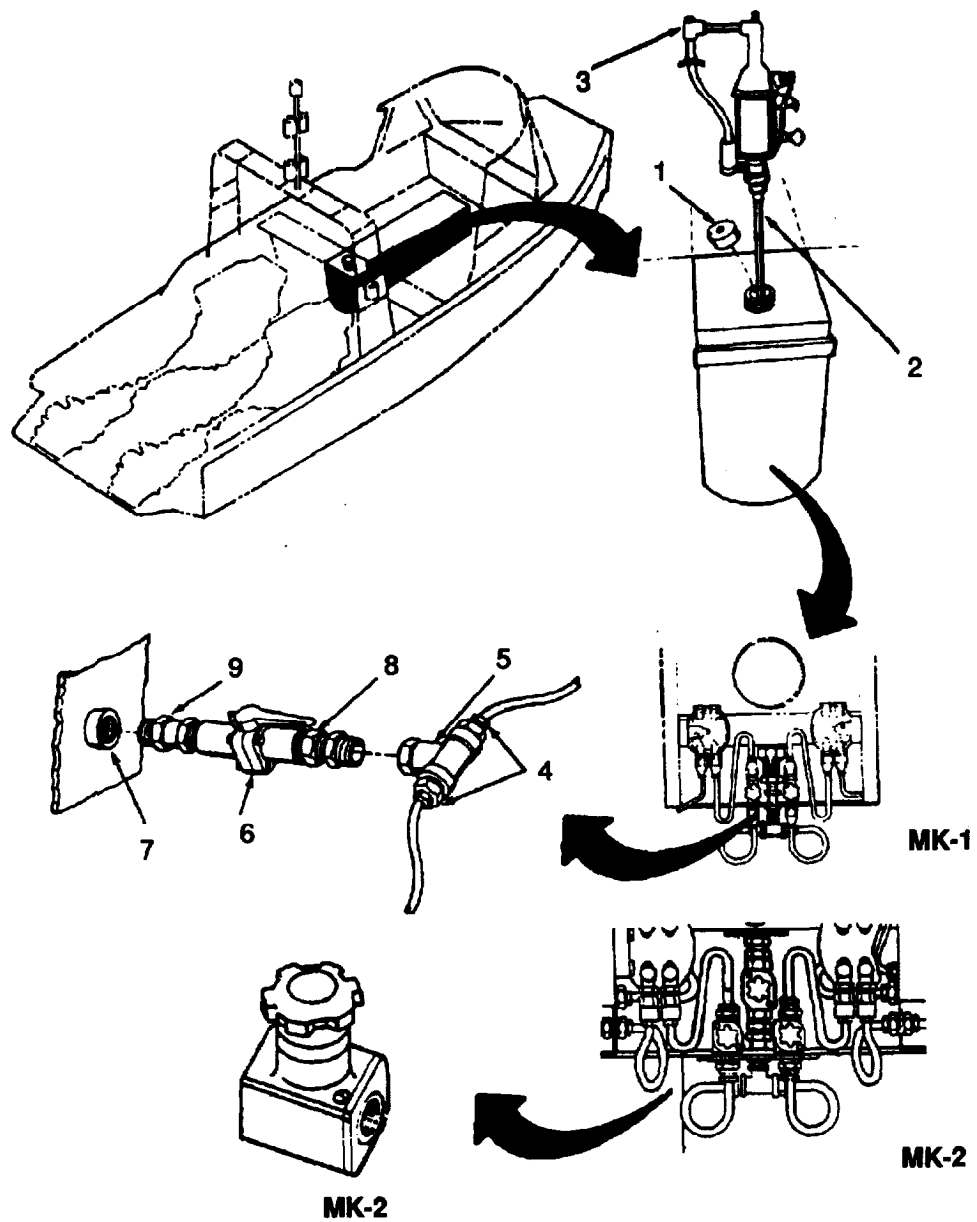

REMOVE:

1. Open and secure battery hatch (refer to paragraph 3-154).
2. Open and secure engine hatches (refer to paragraph 3-154).
3. Remove fuel tank cap (1).
4. Insert pump barrel inlet (2) into fuel tank

CAUTION

Do not damage aluminum strainer sleeve in the fuel tank when using pump.

5. Insert pump outlet hose (3) in 55 gallon drum.
6. Pump fuel from fuel tank to 55 gallon drum until tank is empty.
7. Remove pump barrel inlet (2) and replace fuel tank cap.
8. Place 2 quart liquid measure under connections (4) at end of pipe tee (5).
9. Use 16 mm open end wrench to remove nuts (4) securing tubing to tee pipe.
10. Using 1-1/4 inch open end wrench at tank side of shutoff valve (6) remove valve (6) and pipe tee (5) from tank nipple (7).
11. Use 1-1/4 inch open end wrench on shutoff valve (6) and 1-1/16 inch open end wrench on union (8) to remove union (8) and pipe tee (5) from shutoff valve (6).

REPLACE:

1. Cover threads of union (8) with pipe tape.

CAUTION

Do not cross-thread union. Damage may result to the pipe tee and leakage may occur.

2. Start union (8) in port of shutoff valve (6) and turn until hand tight.
3. Cover threads of tank nipple (7) with pipe tape and start shutoff valve (6) by turning until hand tight
4. Using 1-1/4 inch open end wrench tighten tank nipple nut (9). Be sure fuel valve shutoff (6) handle is up.

CAUTION

Do not use any type of sealant on tubing nuts In the fuel system. Sealant may contaminate fuel.

5. Install end of tubing in pipe tee (5) and tighten nut (4) using 16 mm wrench.
6. Put approximately 15 gallons (56.8 liters) of fuel in tank
7. Rub fingers around connection between tank and shutoff valve (6) for signs of leak
8. Open shutoff valve (6) and check connection at outlet port of valve (6).
9. Check each tubing nut (4) at pipe tee connection for sign of leaking.
10. Close engine hatches.
11. Close battery hatches.

3-60. FUEL WATER SEPARATOR SERVICING INSTRUCTIONS

TOOLS: None

PARTS/MATERIALS: None

1. Open and secure engine hatches (refer to paragraph 3-154).

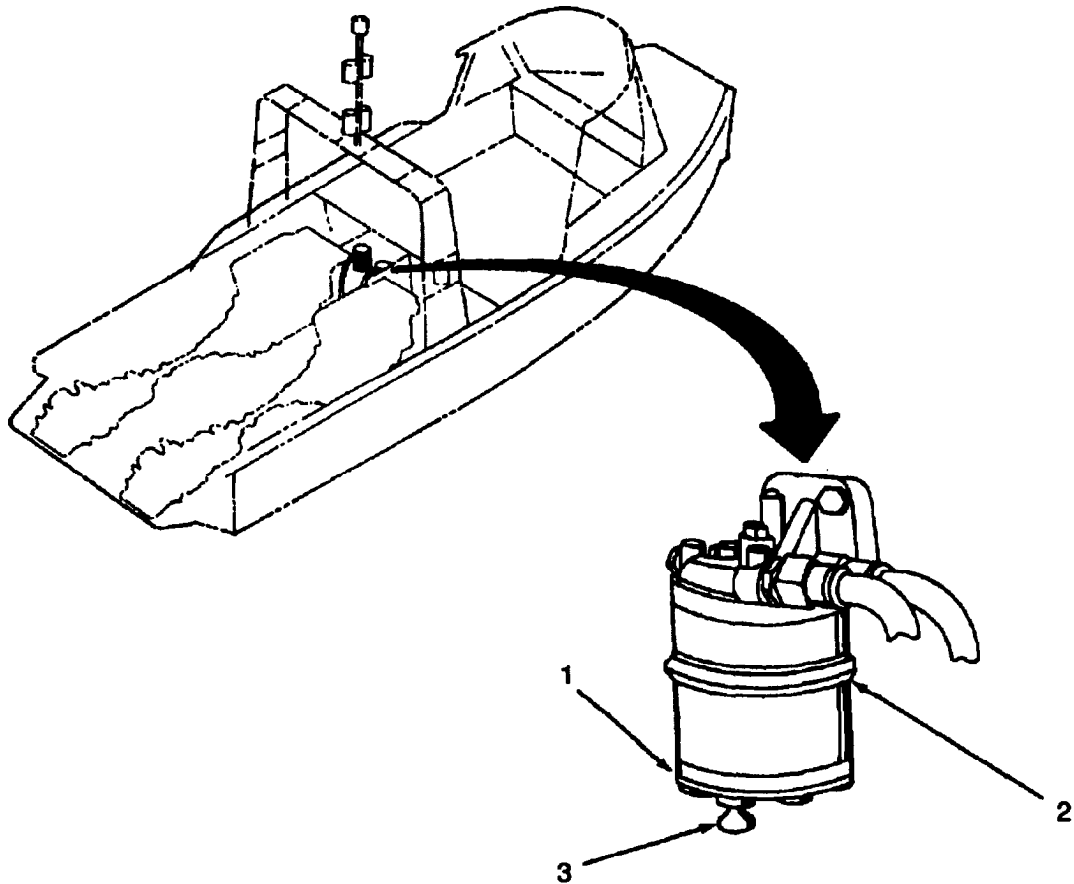

2. Visually check fuel water separator trap (1) for water.
3. To drain fuel water separator (2), loosen drain tap plug (3) and drain into container until dean fuel runs. Clean up spilled fuel.
4. Tighten drain tap plug (3) finger tight.
5. Bleed fuel system (refer to paragraph 3-64).
6. Close engine hatches.

3-61. FUEL WATER SEPARATOR REPLACEMENT INSTRUCTIONS

TOOLS: Two 17 mm Box Wrenches
15mm Open End Wrench

PARTS/MATERIALS: Fuel Water Separator
Liquid Container, One Pint Capacity

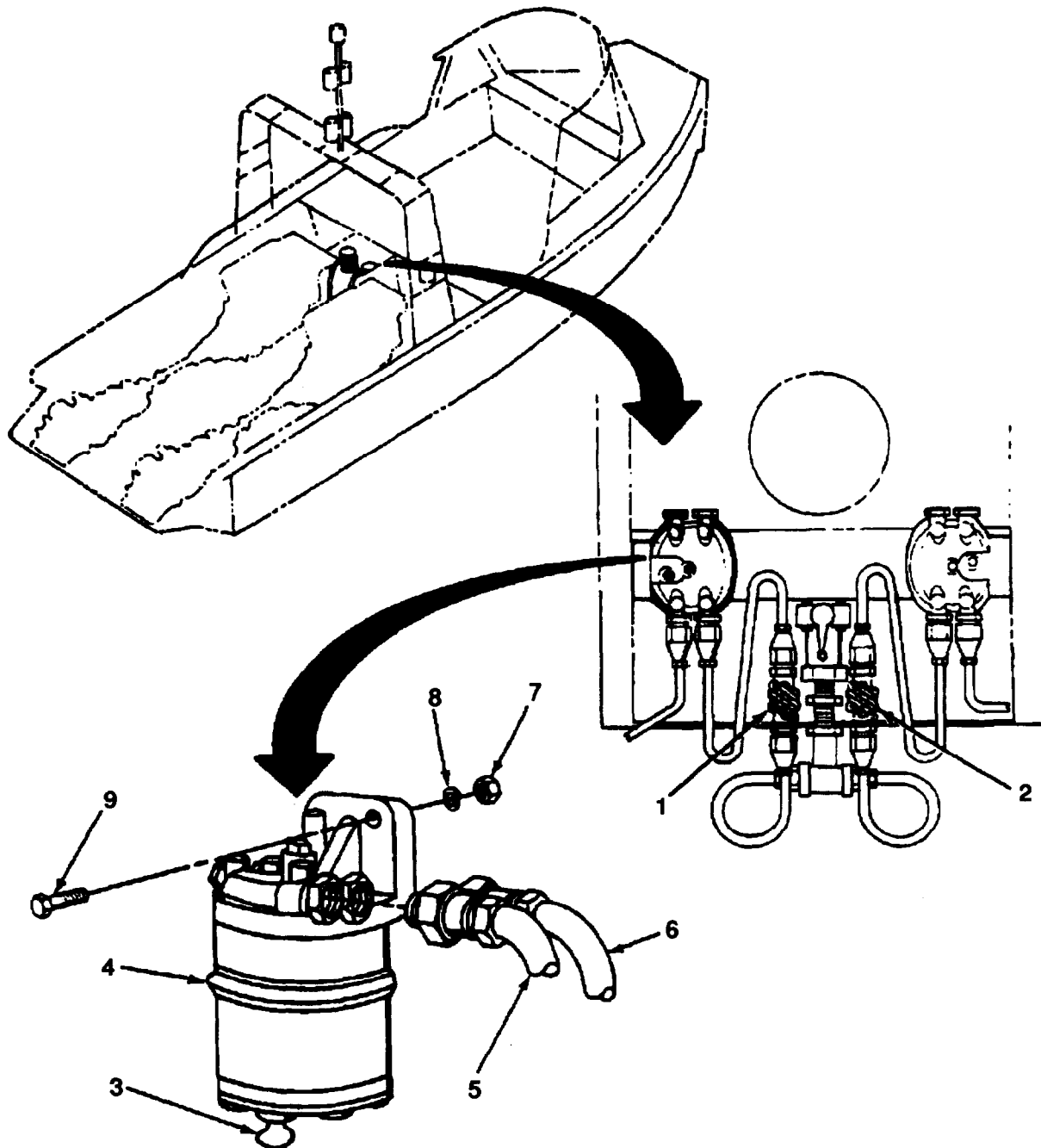

REMOVE :

1. Open and secure engine hatches (refer to paragraph 3-154).
2. Open and secure battery hatch (refer to paragraph 3-154).
3. Shut off fuel supply to fuel water separator by turning handle on engine fuel shutoff valve (1) or (2) as applicable.
4. Loosen tap drain plug (3) from fuel water separator (4) and drain fuel into container.
5. Using 15 mm open end wrench remove fuel inlet line (5) and fuel outlet line (6).
6. Drain fuel from inlet and outlet lines into container.
7. Wipe up spilled fuel.
8. Using two 17 mm wrenches remove two nuts (7), washers (8) and bolts (9) which secure fuel water separator to bulkhead support bracket.
9. Remove fuel water separator (4).

INSTALL:

1. Fit fuel water separator (4) to bulkhead support bracket.
2. Install two bolts (9), washers (8) and nuts (7).
3. Tighten bolts using two 17 mm wrenches.
4. Connect fuel inlet line (5) and fuel outlet line (6) to fuel water separator (4).
5. Tighten lines using 15 mm open and wrench.
6. Check and tighten tap drain plug (3) if loose.
7. Open engine fuel shutoff valve (1 of 2).
8. Bleed the fuel system (refer to paragraph 3-64).
9. Close engine and battery hatches.

3-62. FUEL FILTERS REPLACEMENT INSTRUCTIONS

TOOLS: 7/16 inch Box Wrench

7/16 inch Socket

1/2 inch Box Wrench

9/16 inch Box Wrench

Torque Wrench

PARTS/MATERIALS: Fuel Container, One Quart Capacity

Fuel Filter Element

Lint-free Cloth

MK 1

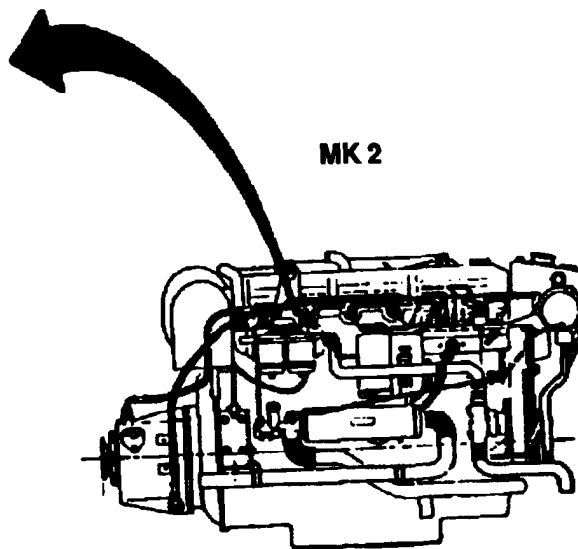
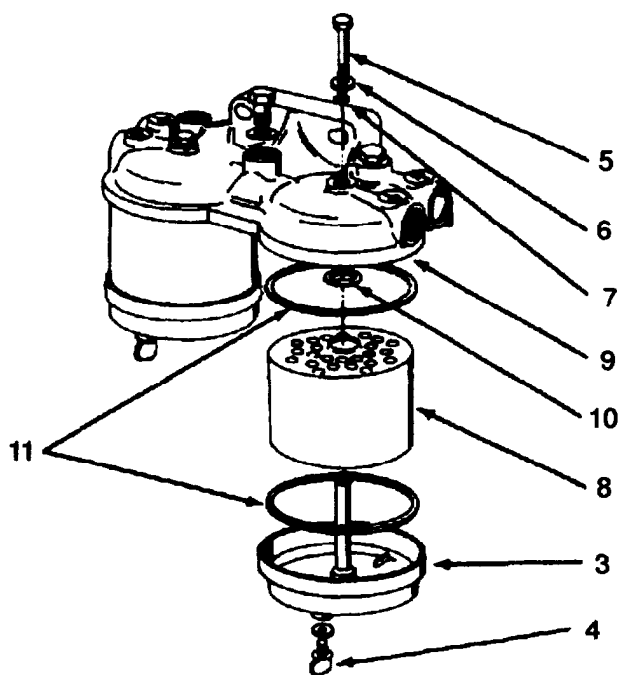
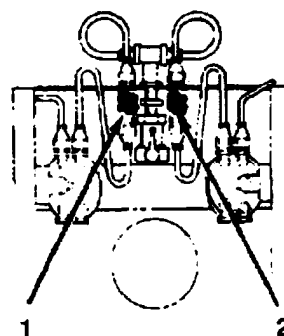
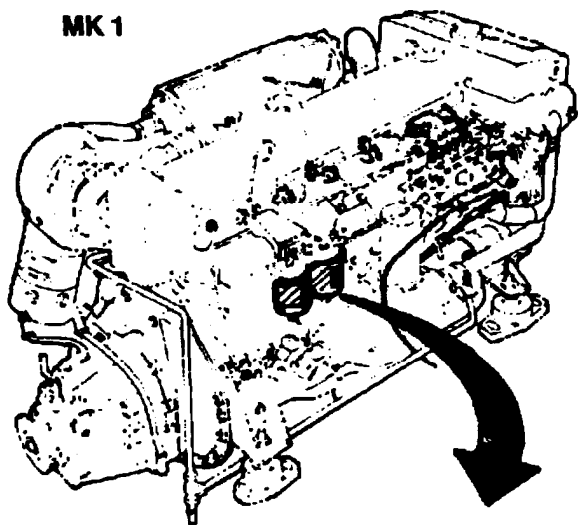

REMOVE:

1. Open and secure engine hatches (refer to paragraph 3-154).
2. Open and secure battery hatch (refer to paragraph 3-154).
3. Close fuel shutoff valve (1 or 2) by turning as shown.
4. Drain fuel fitter bowl (3) into fuel container by loosening tap drain plug (4).
5. Using 7/16 inch wrench remove center bolt (5), washer (6), o-ring (7), o-ring (10), sealing rings (11) and filter (8) from main body (9) and bowl (3).
6. Remove and discard o-ring (7), fuel fitter element (8), o-ring (10), and two sealing rings (11).

CAUTION

Do not use rags to clean fuel bowl. Could cause contamination or clogging.

7. Clean bowl (3) with lint-free cloth.

INSTALL:

1. Fit new sealing rings (11) to main body (9) and fitter bowl (3).
2. Fit new O-ring (10) to main body (9).
3. Fit fitter element (8) to main body (9) and filter bowl (3).
4. Install center bolt (5) through washer (6), with new o-ring (7), and main body (9) into shaft of fitter bowl (3).
5. Tighten center bolt to 5 - 6 ft-lb (6.8 to 8.1 N•m) torque using socket and torque wrench.
6. Tighten tap drain plug (4) finger tight.
7. Open fuel shutoff valve (1 or 2) by turning as shown.
8. Bleed fuel system (refer to paragraph 3-64).
9. Close engine and battery hatches.

3-63. FUEL LIFT PUMP ASSEMBLY REPLACEMENT INSTRUCTIONS

TOOLS: 1/2 inch Box Wrench
1/2 inch Open End Wrench
Putty Knife
7/16 inch Box Wrench
5/6 inch Box Wrench

PARTS/MATERIALS: Fuel Lift Pump
Adapter Gasket
Lift Pump Flange Gasket
Rags

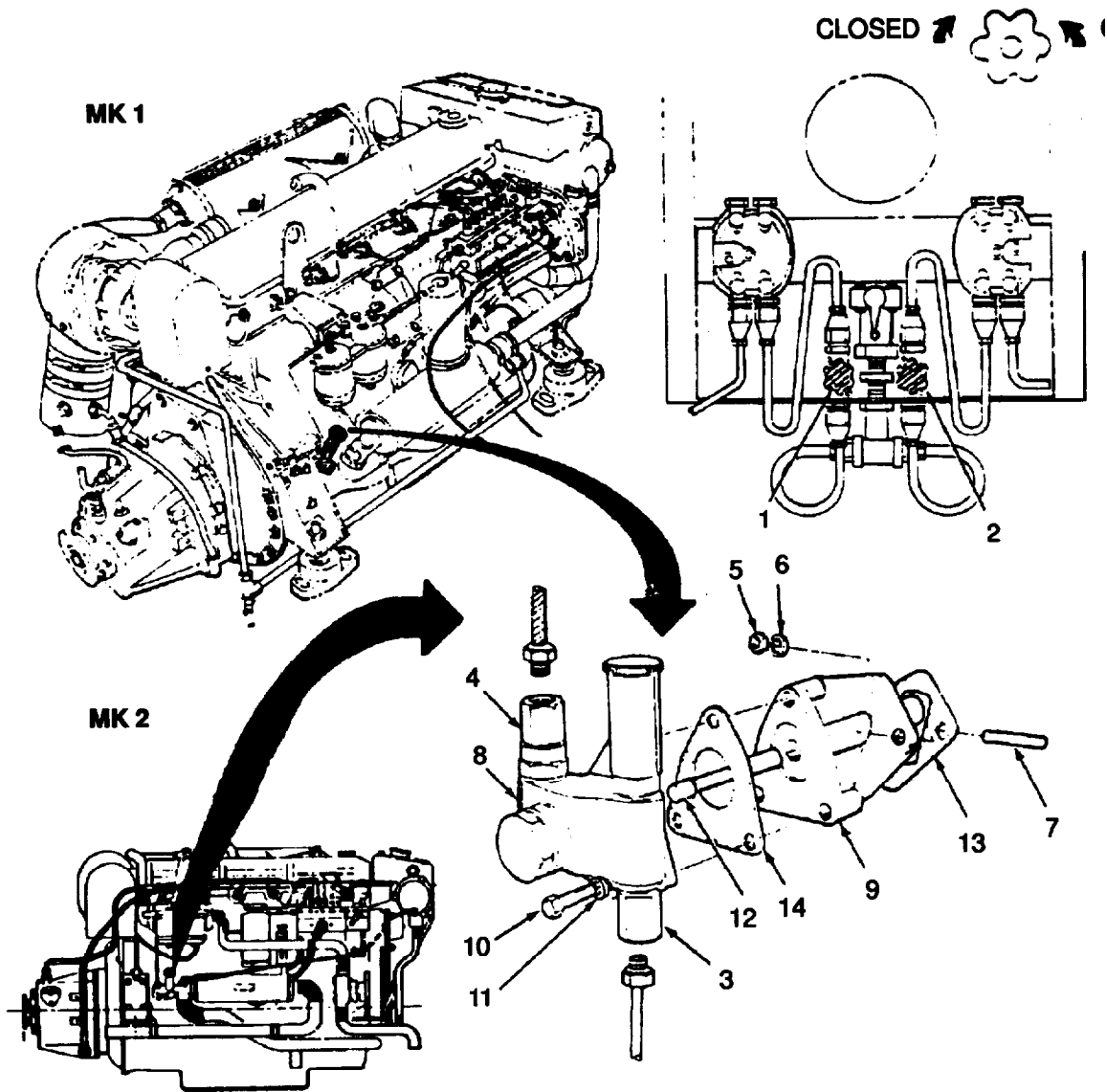

REMOVE:

1. Open and secure engine hatches (refer to paragraph 3-154).
2. Close engine fuel shutoff valve (1) or (2) as applicable.

NOTE

If starboard fuel lift pump is to be replaced remove buoyancy flotation material (refer to paragraph 3-152). There is no requirement to remove buoyancy flotation material to replace lift pump on port engine.

3. Disconnect fuel inlet line (3) at base of pump using 1/2 inch open end wrench.
4. Using 1/2 and 5/8 inch open end wrench disconnect fuel outlet line (4).
5. Using 1/2 inch box wrench remove two nuts (5) and two washers (6) from stud (7).
6. Remove pump (8) and adapter housing (9) from engine block by pulling straight out.
7. Using 7/16 inch box wrench remove three bolts (10) and washers (11) from fuel lift pump (6) and adapter housing (9).
8. Separate pump from adapter housing and remove push rod (12).
9. Remove flange gasket (13) and pump-to-adapter gasket (14) and clean mounting surfaces of engine block and housing adapter using putty knife.

INSTALL:

1. Assemble fuel lift pump (8), pump to adapter gasket (14), push rod (12) and adapter housing (9).
2. Install three washers (11) and bolts (10) and tighten using 7/16 inch wrench.
3. Install flange gasket (13) on engine mounting.
4. Fit fuel lift pump assembly to engine. Install two washers (6) and nuts (5) and tighten using 1/2 inch box wrench.
5. Connect fuel outlet line (4) and fuel inlet line (3) and tighten using 1/2 and 5/8 inch open end wrenches.
6. Open engine fuel shutoff valve (1) or (2) as required.
7. Bleed the fuel system (refer to paragraph 3-64).

NOTE

For starboard engine pump replacement only reinstall buoyancy flotation material (refer to paragraph 3-152).

8. Close engine hatches.

3-64. FUEL SYSTEM BLEEDING INSTRUCTIONS

TOOLS: 9/16 inch Box Wrench
1/2 inch Box Wrench

PARTS/MATERIALS: Container, Two Quart Capacity

1. Open and secure engine hatches (refer to paragraph 3-154).

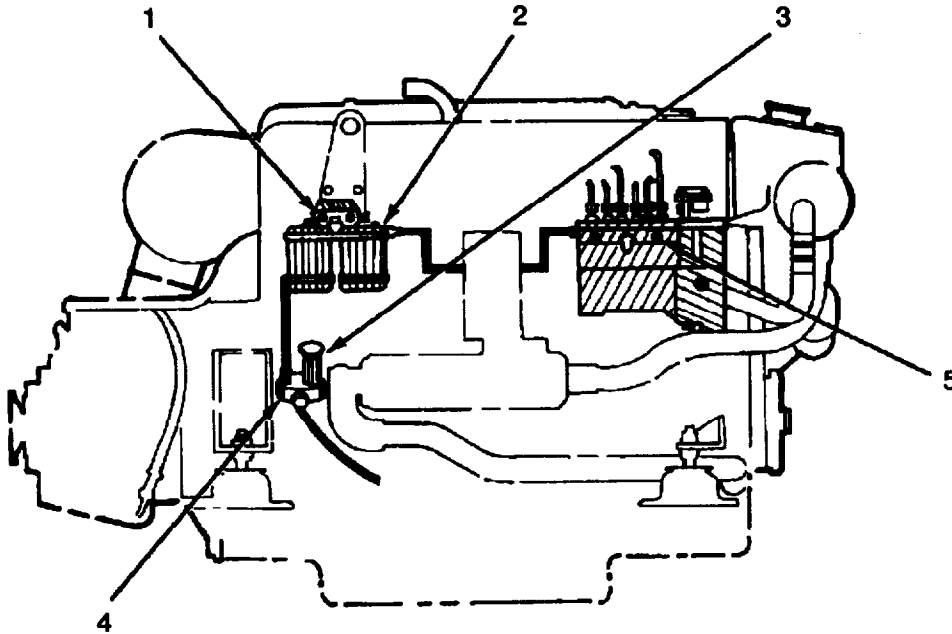

NOTE

Insure that there is fuel in tank and fuel valves are turned on.

2. Open center bleed screw (1) on fuel filters (2) using 9/16 inch box wrench.

NOTE

Place container under bleed screw (1) to catch fuel.

3. Unscrew lift pump plunger (3) and operate priming pump (4) until a flow of fuel, free of air bubbles, flows from bleed screw (1) into container. Clean up spilled fuel.
4. Close center bleed screw (1) in fuel filters using 9/16 inch box wrench.
5. Open forward bleed screw (5) on injection pump using 1/2 inch box wrench.

NOTE

Place container under bleed screw (5) to catch fuel.

6. Operate priming pump (4) until fuel, free of air bubbles, flows from bleed screw into container. Clean up spilled fuel.
7. Close forward bleed screw (5) on injection pump and tighten using 1/2 inch box wrench.
8. Secure priming pump plunger (3) by screwing it back into barrel.
9. Clean up all fuel spillage.
10. Close engine hatches.

3-65. EXHAUST FLEXIBLE BELLOWS REPLACEMENT INSTRUCTIONS (MK1) - PORT AND STARBOARD

TOOLS: 1/2 inch Socket
Ratchet

PARTS/MATERIALS: Exhaust Bellows

REMOVE:

1. Open and secure engine hatches (refer to paragraph 3-154).

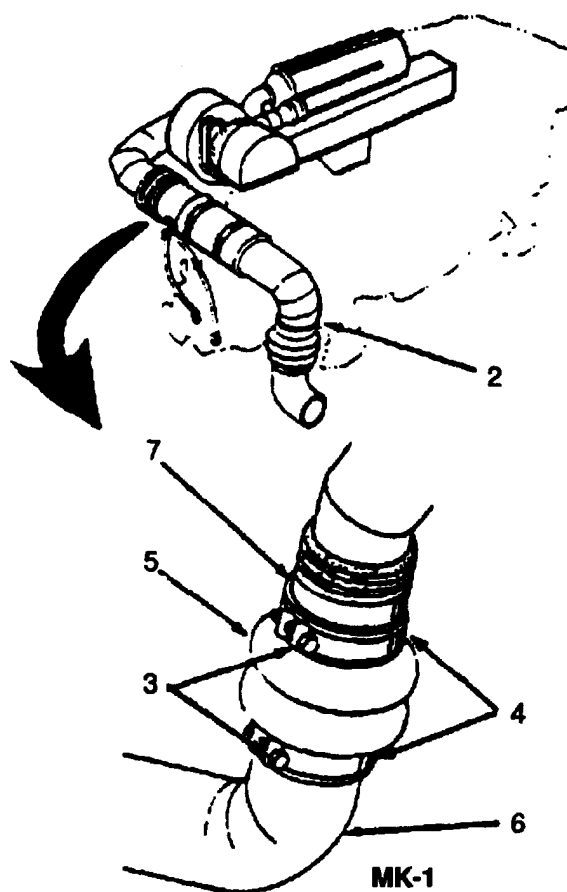

Port Engine Bellows (1) Removal

2. Using socket loosen two nuts (3) on clamps (4) that secure bellows (5) to transmission oil cooler (7) on MK1 and exhaust pipe (6) and remove buoyancy block.
3. Remove and discard bellows and retain bellows clamps for installation of replacement.

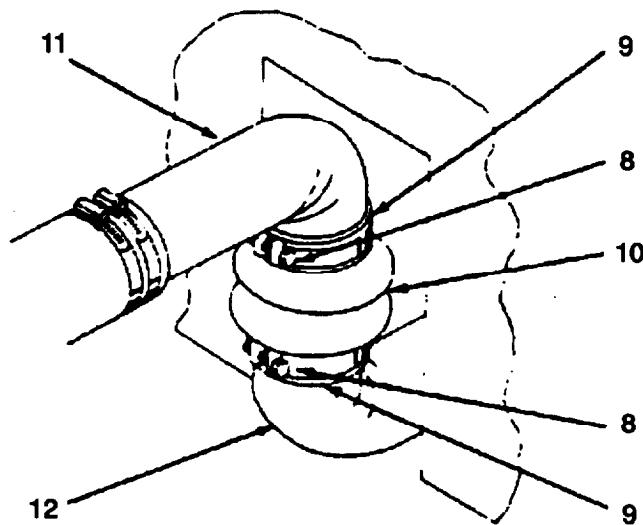

Starboard Engine Bellows (2) Removal:

4. Using socket loosen two nuts (8) on clamps (9) that secure bellows (10) to connector piping (11) and exhaust pipe (12).
5. Remove and discard bellows.
6. Retain bellows clamp for installation of replacement.

INSTALL:

Port Engine Bellows (1) Removal:

1. Place bellows clamps (4) on replacement bellows (5) and aline so that clamp nuts will face toward engine compartment when bellows is installed.
2. Install bellows (5) between transmission oil cooler (7) and exhaust pipe (6) and install buoyancy block.
3. Tighten clamps using socket.

Starboard Engine Block (2) Installation:

4. Install bellows clamps (9) on replacement bellows (10) and aline so that clamp nuts (8) will face toward engine compartment when bellows is installed.
5. Install bellows (10) between connector piping (11) and exhaust pipe (12).
6. Tighten clamps using socket.
7. Close engine hatches.

3-66. EXHAUST FLEXIBLE BELLOWS REPLACEMENT INSTRUCTIONS (MK2 - PORT AND STARBOARD)

TOOLS: Screwdriver

PARTS/MATERIALS: Port Engine Exhaust Bellows
Starboard Engine Exhaust Bellows

REMOVE:

1. Open and secure engine hatches (refer to paragraph 3-154).

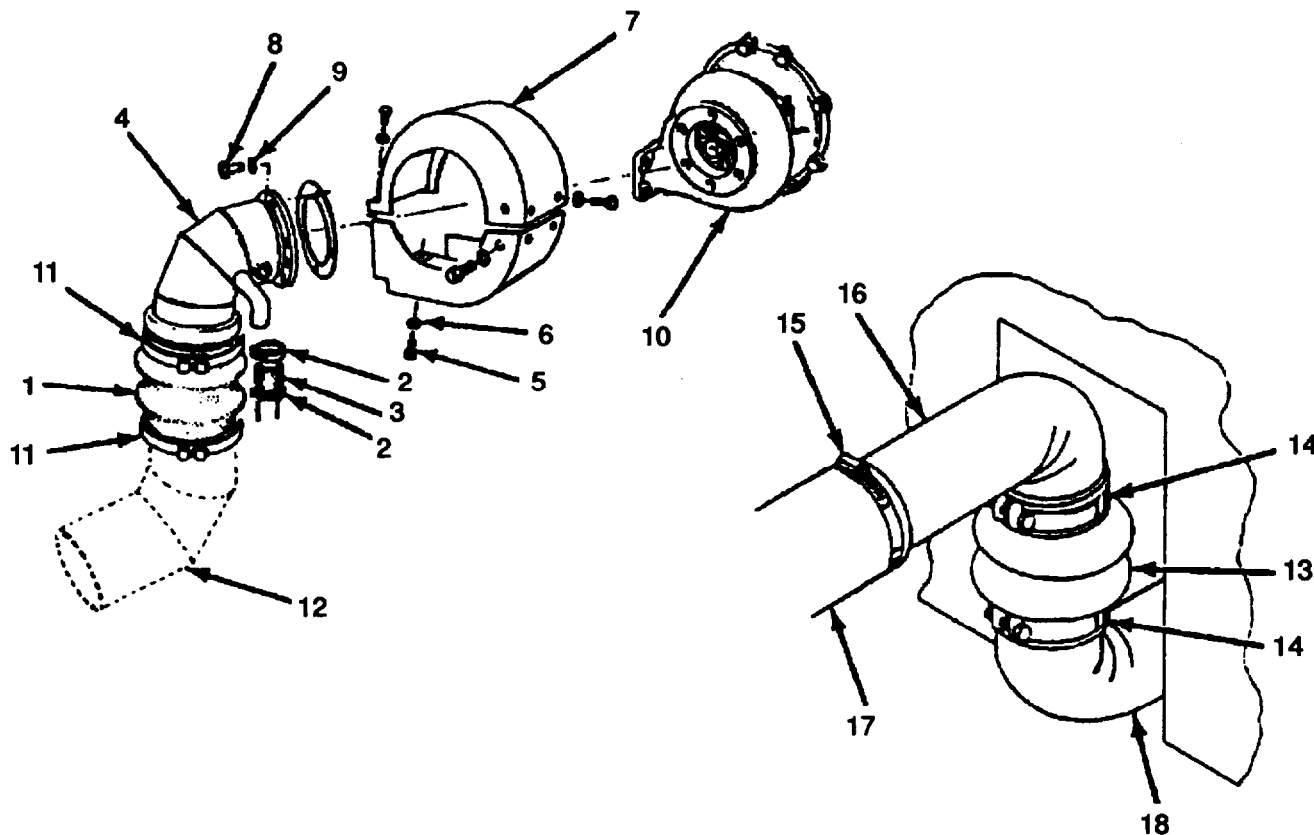

Port Engine Exhaust Bellows (1) Removal:

2. Loosen hose clamp (2) securing raw water intake hose (3) to exhaust elbow (4) and remove hose.
3. Remove seven screws (5) and lockwashers (6) from heat shield (7) and remove heat shield.
4. Remove four screws (8) and lockwashers (9) securing exhaust elbow (4) to turbocharger (10).
5. Loosen two bellows clamps (11) on port engine exhaust bellows (1).
6. Remove exhaust elbow (4) from port engine exhaust bellows (1).
7. Remove port engine exhaust bellows (1) from exhaust port (12).

Starboard Engine Exhaust Bellows(13) Removal:

8. Loosen two bellows clamps (14) on starboard engine exhaust bellows.
9. Loosen hose clamp (15) securing connecting pipe (16) to exhaust hose (17).
10. Remove connecting pips (16) from starboard engine exhaust bellows (13) by pulling pipe upward.
11. Remove starboard engine exhaust bellows from exhaust port (18).

INSTALL:

Port Engine Exhaust Bellows (1) Installation:

1. Place bellows clamps (11) on replacement bellows (1) and align so that clamp nuts will face toward engine compartment when bellows is installed.
2. Install port engine exhaust bellows (1) on exhaust port (12).
3. Install exhaust elbow (4) into port engine exhaust bellows.
4. Tighten two bellows clamps (11) on exhaust port engine bellows.
5. Secure exhaust elbow (4) to turbocharger (10) by installing four lockwashers (9) and screws (8).
6. Install heat shield (7) by installing seven lockwashers (6) and screws (5).
7. Install raw water intake hose (3) on exhaust elbow (4) and tighten hose clamp (15).

Starboard Engine Exhaust Bellows (13) Installation:

8. Install bellows clamps (14) on replacement bellows (13) and align so that clamp nuts will face toward engine compartment when bellows is installed.
9. Install starboard engine exhaust bellows (13) on exhaust port (18).
10. Install connecting pips (16) in starboard engine exhaust bellows (13).
11. Secure connecting pipe (16) to exhaust hose (17) by tightening hose clamp (15).
12. Tighten two bellows clamps (14) on starboard engine exhaust bellows.

3-67. PIPING, HOSES, AND FITTINGS REPLACEMENT INSTRUCTIONS (COOLING SYSTEM)

TOOLS: Flat Tip Screwdriver, 4 inch
1/2 inch Box Wrench

NOTE

Before removing pips or hose from fresh water cooling system of MK1 or either cooling system of MK2, system must be drained and coolant collected in suitable container(s). Refer to paragraph 3-63 for MK1 or 3-70 for MK2.

REMOVE:(General)

1. Open and secure engine hatches (refer to paragraph 3-154).
2. Using screwdriver loosen hose clamps at both ends of pipe.
3. Using wrench remove pips support braces.
4. Slide hose enough to free pipe.
5. Remove pips, hoses, and hose fittings.

INSPECT:

1. Inspect pipe, hoses, and hose fittings for damage or deterioration.
 - a. Replace pips if split, bent or otherwise damaged.
 - b. Replace hoses if split, cracked, cut or otherwise damaged.

INSTALL:

1. Reinstall pipe.
2. Loosely install clamps on hose.
3. Slide hose to cover pips and pips connectors beyond flare.
4. Using screwdriver tighten hose clamps.
5. Using wrench reinstall pipe support braces.

3-68. DRAIN AND REFILL FRESH WATER COOLING SYSTEM (MK1)

TOOLS: Suitable Container(s), approximately 8 gallons

PARTS/MATERIALS: Coolant

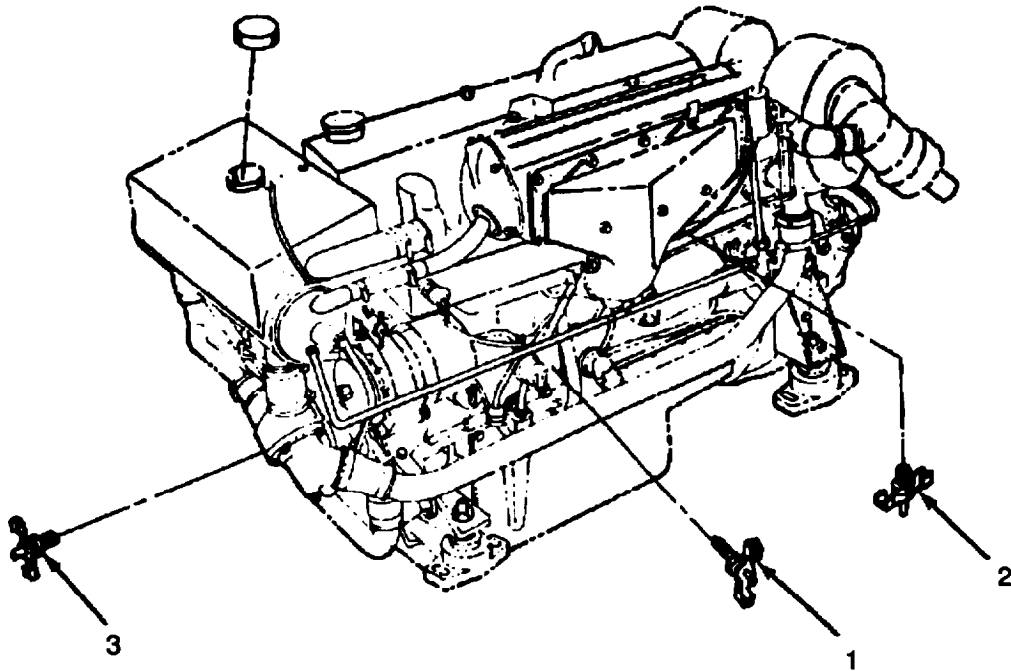

DRAIN:

1. Carefully remove fresh water filler cap.
2. Drain water from fresh water system by opening all three fresh water drain points:
 - a. Cylinder block (1).
 - b. Exhaust manifold, rear (2).
 - c. Thermostat pipe (3).
3. Collect coolant and dispose of as directed.

REFILL:

1. To refill fresh water system, close three fresh water drain points.
2. Refill fresh water system with coolant allowing an air space of approximately one inch at top of header tank
3. Reinstall fresh water filler cap.
4. Close engine hatches.

3-69. DRAIN AND REFILL PRIMARY AND SECONDARY COOLING SYSTEMS (MK2)

TOOLS: Adjustable Wrench
7/16 inch Box Wrench
Suitable Container(s), approximately 8 gallons

PARTS/MATERIALS: Coolant
Teflon Taps

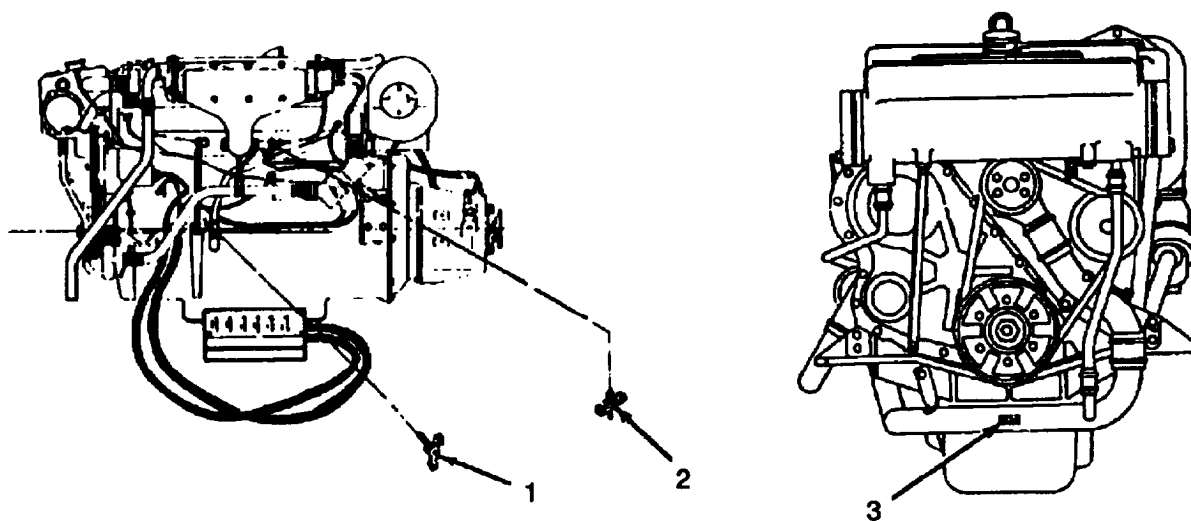

DRAIN:

NOTE

The boat must be out of water before draining cooling systems.

1. Open and secure engine hatches (refer to paragraph 3-154).
2. Carefully remove coolant filler cap.
3. Open coolant drain points at cylinder block (1) and exhaust manifold, rear (2).
4. Using adjustable wrench, remove coolant drain plug at primary water pump feed pipe (3).

NOTE

One keel cooler, when filled with coolant, weighs approximately 25 pounds. Before draining keel coolers, remove both keel coolers. Refer to paragraph 3-87.

5. Using box end wrench, open coolant drain plug at both keel coolers(4).
6. Collect and dispose of coolant as directed.

REFILL:

1. To refill cooling systems, close coolant drain points.
2. Wrap three drain plug threads with Teflon tape and install three drain plugs.
3. Refill cooling systems with coolant allowing an air space of approximately 1 inch at top of header tank
4. Reinstall cooler filler cap.
5. Close engine hatches.

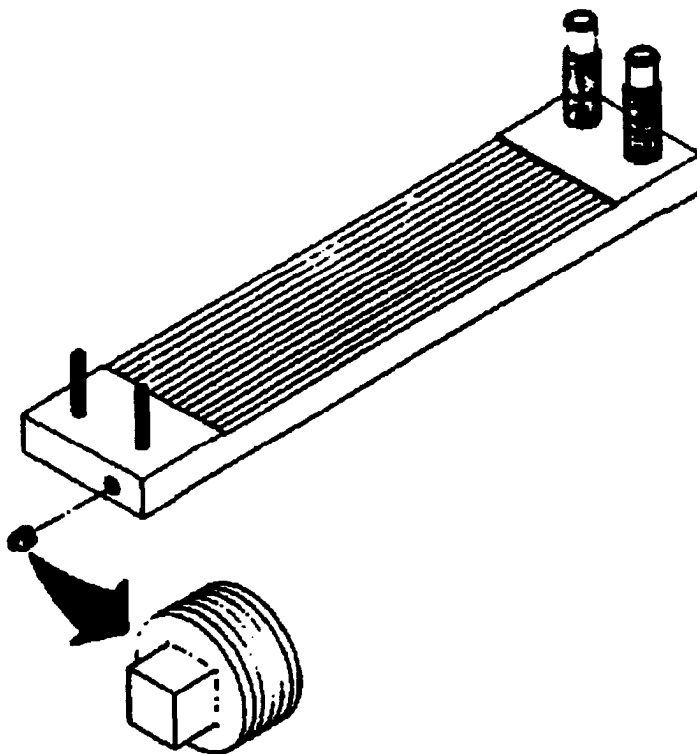

3-70. FRESH (MK1) OR PRIMARY (MK2) WATER PUMP REPLACEMENT INSTRUCTIONS (PORT AND STARBOARD)

TOOLS: 1/2 inch Socket
6 inch Extension
10 inch Extension
Putty Knife
Flat Tip Screwdriver, 4 inch
Ratchet

PARTS/MATERIALS: Water Pump
Gasket
Silicone Sealant

REMOVE:

1. Open and secure engine hatches (refer to paragraph 3-154).
2. Open and secure battery hatch (refer to paragraph 3-154).
3. Drain pooling system (refer to paragraph 3-69 for MK2 and 3-68 for MK1 .

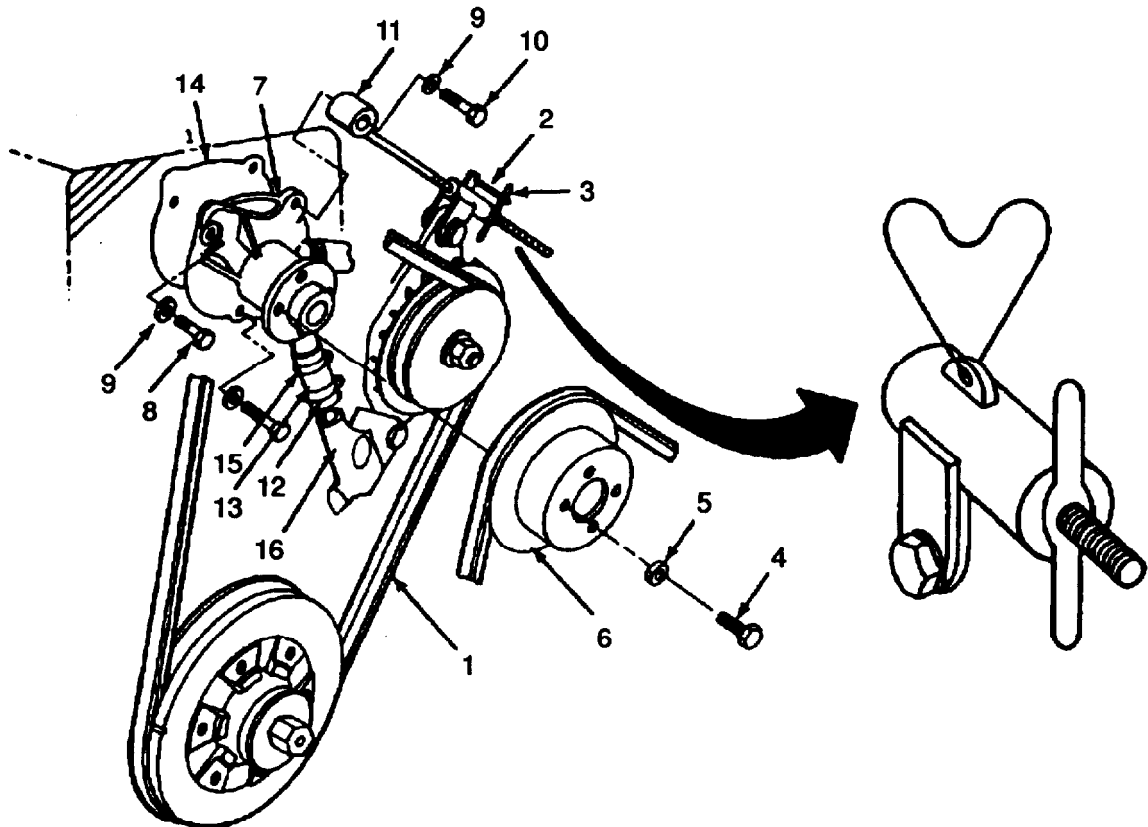

4. Release tension on V-belt (1) by unlocking adjuster assembly lock (2) and turning adjuster handle (3) clockwise.
5. Remove V-belt (1).
6. Using socket with 6 inch extension remove four bolts (4) and washers (5) securing water pump pulley (6) to water pump (7).
7. Remove pulley (6) from pump (7).
8. Using socket with 10 inch extension remove three bolts (8) and washers (9) securing pump (7) to engine block.

9. Using socket with 10 inch extension remove one bolt (10) and washer (9) in the top right position securing the adjuster rod (11) and water pump (7) to engine block.
10. Using screwdriver loosen hose clamp (12) on pump inlet connector hose (13).
11. Slide pump inlet connector hose (13) and pump (7) from engine.
12. Remove gasket (14) and clean engine block surface using putty knife.
13. Using screwdriver loosen hose clamp (15) on connector hose (13) and remove from pump (7).

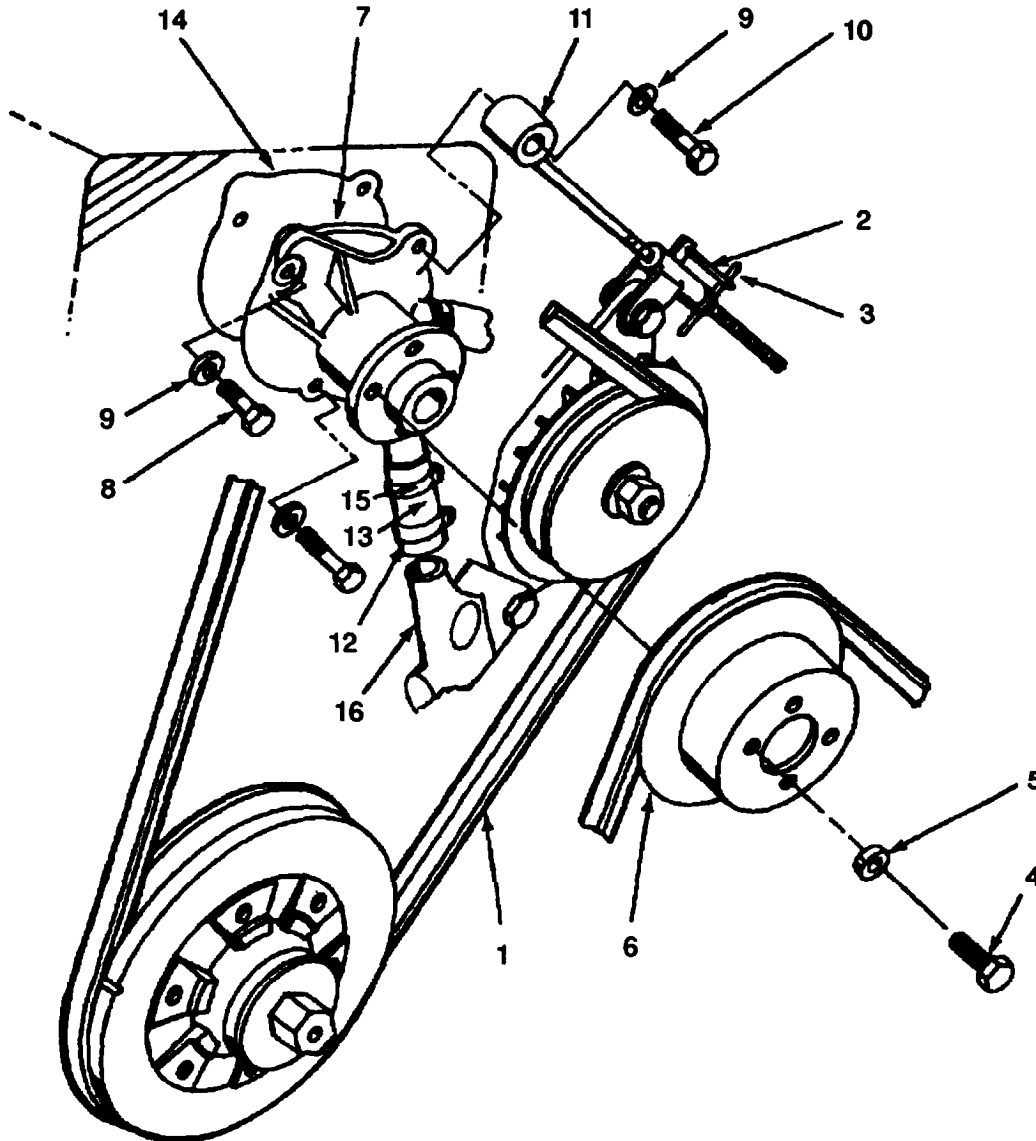

INSTALL:

1. Reinstall connector hose (13) and clamp (15) on replacement pump (7).
2. Coat both sides of water pump gasket (14) with silicone sealant and position on engine.
3. Fit connector hose (13), clamp (12) and pump (7) to connector (16) and engine block

NOTE

Insure long bolt (10) is installed at top right position on water pump (7).

4. Install three washers (9) and bolts (8) securing pump to engine block.
5. Install one washer (9) and bolt (10) thru adjuster rod (11) and water pump (7) to engine block.
6. Tighten bolts (10 and 8) using socket with 10 inch extension.
7. Position hose clamps (12 and 15) on inlet hose and tighten with screwdriver.
8. Reinstall water pump pulley (6) on water pump (7) using four washers (5) and bolts (4) and tighten with socket and 6 inch extension.

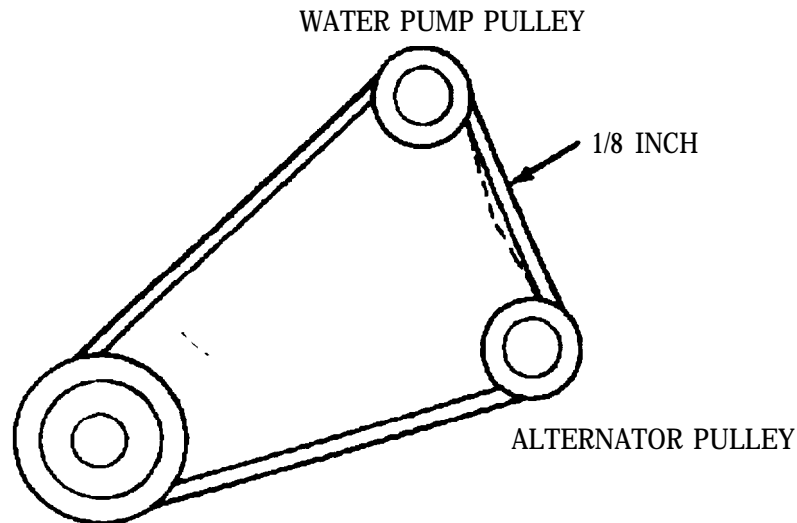

9. Replace V-belt (1) on alternator, crankshaft and water pump pulleys and adjust to proper tension using adjuster handle (3). Tighten belt until the free movement between the water pump pulley and alternator when pushed is not in excess of 1/8 inch as shown in figure above.
10. Fill with coolant (refer to paragraphs 3-69 for MK2 and 3-68 for MK1).

3-71. HEADER TANK/HEAT EXCHANGER REPAIR INSTRUCTIONS (MK1)

TOOLS: Flat Tip Screwdriver

Putty Knife

11/16 inch Box Wrench

Two 1/2 inch Box Wrenches

7/32 inch Hex Key Wrench (Allen)

PARTS/MATERIALS: Gasket, Heat Exchanger

Gasket, Intercooler Pipe Flange

Silicone Sealant

Tube Stack

O-rings

Container, Five Gallon Capacity

REMOVE:

1. Open and secure engine hatches (refer to paragraph 3-154).
2. Open and secure battery hatch (refer to paragraph 3-154).
3. Remove header tank/heat exchanger (refer to paragraph 3-72).

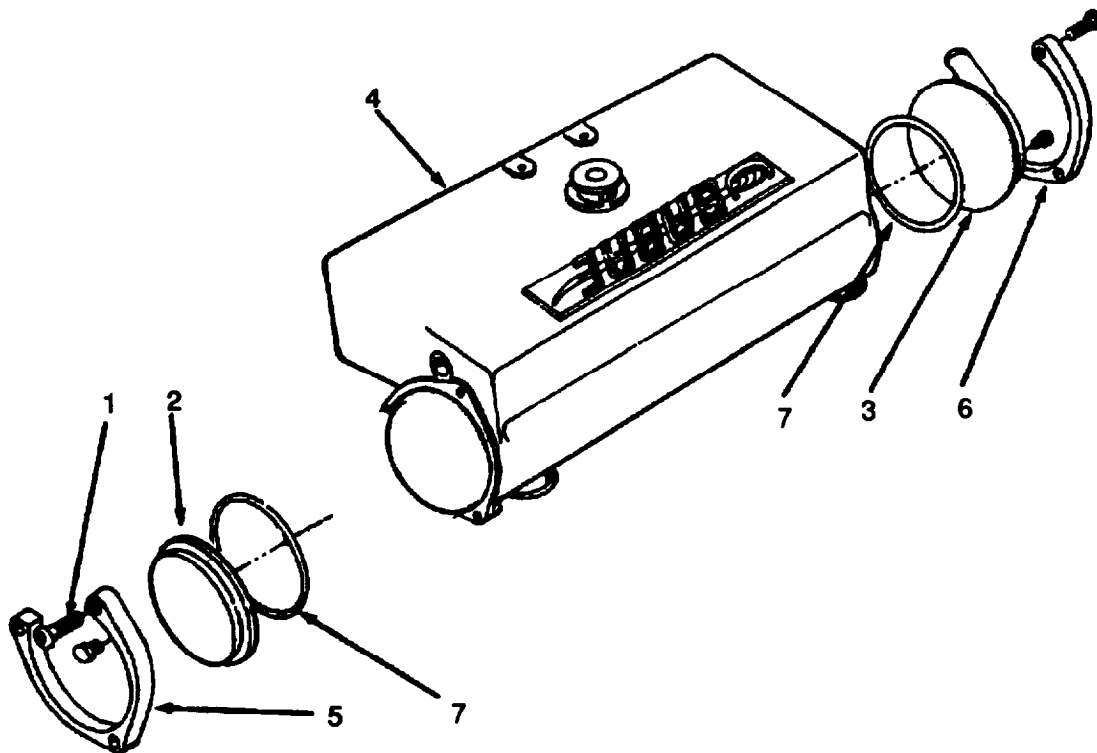

REPAIR:

- I. Using hex key wrench remove six socket head screws (1) securing end covers (2 and 3) to heat exchanger (4).

CAUTION

If particles of rubber are found in heat exchanger, check raw water pump impeller for damage, (see page 24).

2. Remove retaining rings (5 and 6), end covers (2 and 3), and O-rings (7).
3. Discard O-rings.
4. Coat O-rings (7) with sealant (Item 3, App. C) and assemble O-rings (7), end covers (2 and 3), and retaining rings (5 and 6) on heat exchanger (4).
5. Using hex key wrench reinstall six socket head screws (1) securing end covers (2 and 3) to heat exchanger (4).
6. Reinstall header tank/heat exchanger (refer to paragraph 3-72).
7. Close battery hatch.
8. Close engine hatches.

3-72. HEADER TANK REPLACEMENT INSTRUCTIONS

TOOLS: Flat lip Screwdriver

Putty Knife

1/2 inch Socket

Ratchet

1/2 inch Box Wrench

3/4 inch Combination Wrench

PARTS/MATERIALS: Gasket, Heat Exchanger

Gasket, Intercooler Pipe Flange

Silicone Sealant

Header Tank/Heat Exchanger

REMOVE:

1. Open and secure engine hatches (refer to paragraph 3-154).
2. Open and secure battery hatches (refer to paragraph 3-154).

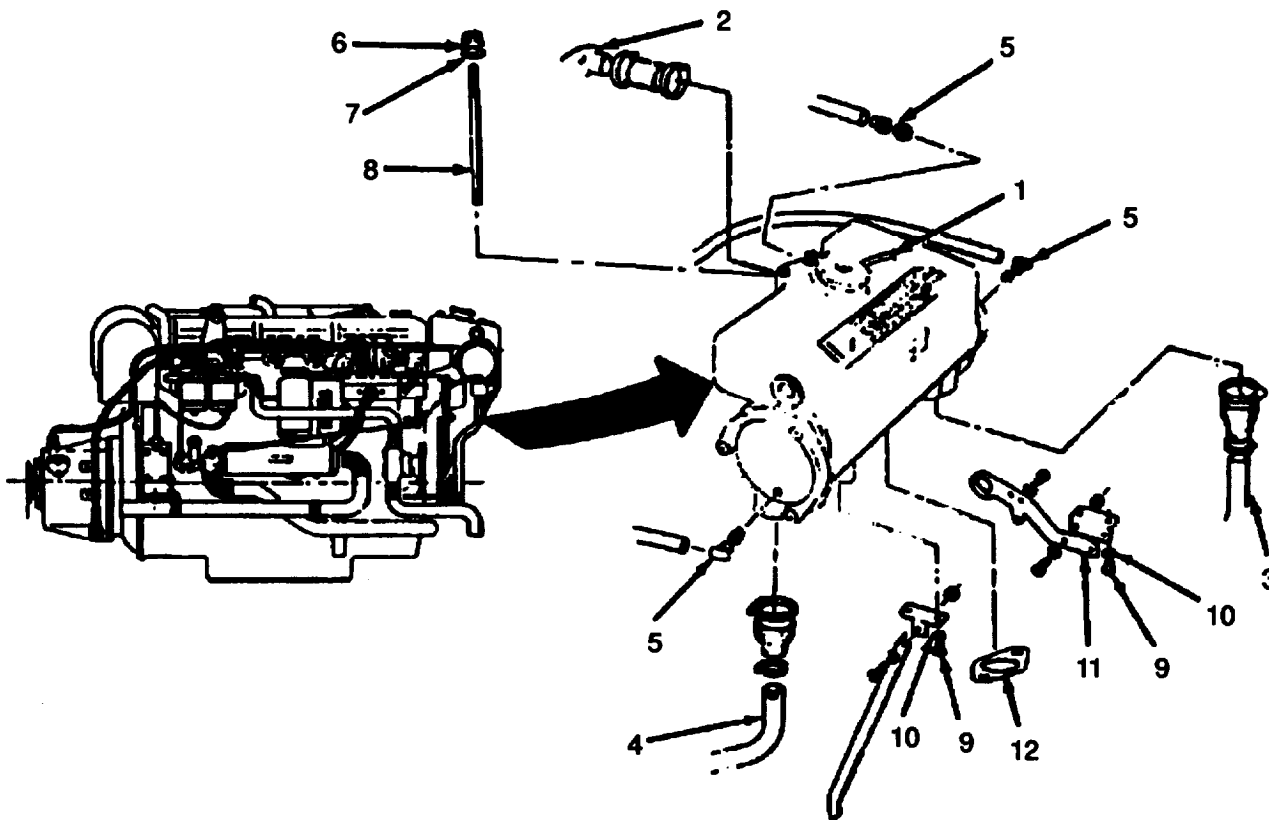

3. Drain both primary and secondary cooling systems (refer to paragraph 3-69).
4. Disconnect overflow drain tube (1) from overflow outlet.
5. Using screwdriver loosen hose clamps on elbow connector (2), header tank to thermostat bypass pipe (3), and header tank to secondary water pump pipe (4).

6. Slide hoses free of header tank pipes.
7. Using 3/4 inch combination wrench remove hose fitting adapters (5) from header tank
8. Using 1/2 inch wrench remove two nuts (6) and washers (7) securing header tank to header tank studs (8).
9. Using socket and ratchet remove four bolts (9) and washers (10) securing header tank to support brackets (11).
10. Lift header tank free of studs (8) and remove from engine.
11. Using putty knife remove gasket (12).
12. Replace header tank.

INSTALL:

1. Coat replacement header tank gasket (12) with silicone sealant (Item 3, App. C).
2. Install gasket (12).
3. Slide header tank onto header tank studs (8).
4. Using socket reinstall washers (10) and bolts (9) securing header tank to support brackets (11).
5. Using 1/2 inch wrench reinstall two washers (7) and nuts (6) securing header tank to header tank studs (8).
6. Using 3/4 inch combination wrench install hose fitting adapters (5) on header tank
7. Slide hoses onto header tank pipes beyond flare.
8. Using screwdriver tighten hose clamp on elbow connector (2) to thermostat bypass pipe (3), and header tank to secondary water pump pipe (4).
9. Connect overflow drain tube (1) to overflow outlet.
10. Fill header tank with coolant (refer to paragraph 3-69).
11. Close engine hatches.
12. Close battery hatch.

3-73. ENGINE THERMOSTAT REPLACEMENT INSTRUCTIONS (PORT OR STARBOARD)

TOOLS: Flat-Tip Screwdriver, 4 inch
7/16 inch Box Wrench
1/2 inch Socket
Ratchet Extension

PARTS/MATERIALS: Thermostat Element
Gasket
O-ring
Silicone Sealant

REMOVE:

1. Open and secure engine hatches (refer to paragraph 3-154).
2. Open and secure battery hatch cover (refer to paragraph 3-154).

MK1

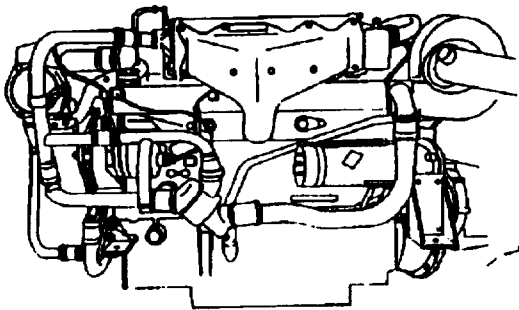

MK2

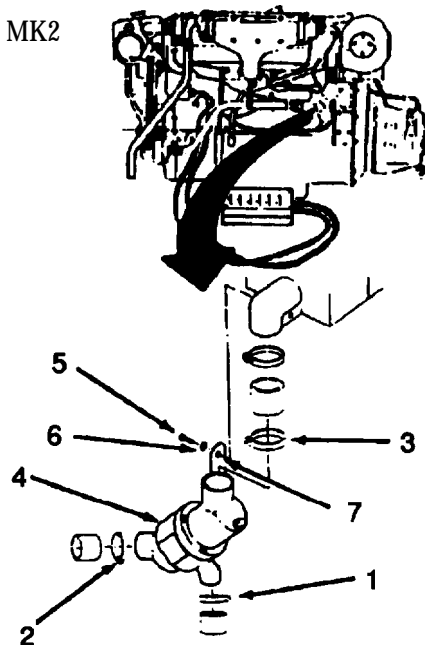

3. Drain fresh cooling system on MK1 (refer to paragraph 3-68). Drain primary and secondary cooling systems on MK2 (refer to paragraph 3-69).
4. Using screwdriver loosen three hose clamps (1,2 and 3) on thermostat housing (4).
5. On MK2, use socket to remove bolt (5) and washer (6) attaching thermostat mounting bracket (7) to engine.
6. Remove thermostat housing (4) from engine by separating from three hose connections at clamps (1,2 and 3).

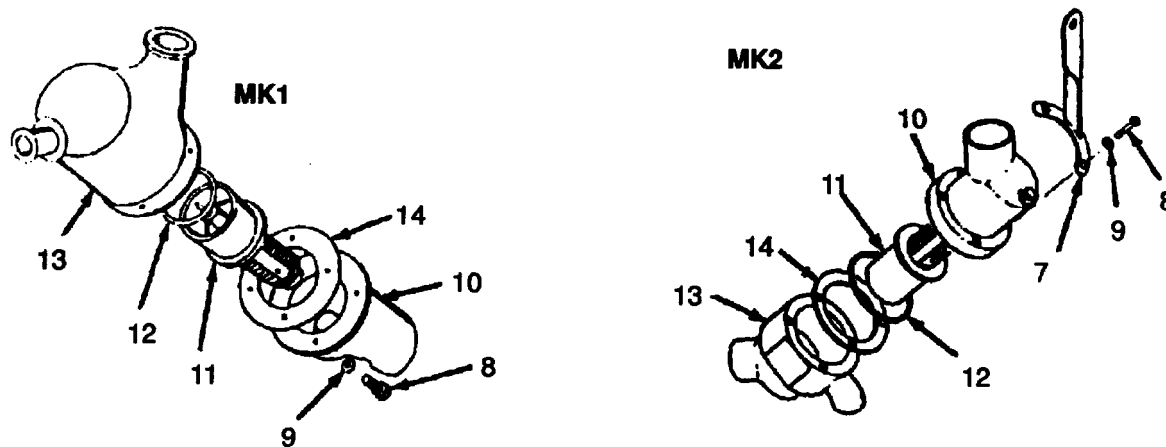

CAUTION

Do not replace thermostat housing without replacing thermostat element.

7. Using wrench remove four bolts (8) and washers (9) from thermostat inlet housing (10). On MK2, remove thermostat mounting bracket (7) from inlet housing.
8. Remove thermostat inlet housing (10), gasket (14), thermostat element (11) and O-ring (12) from outlet housing (13).
9. Pull O-ring (12), thermostat element (11) and gasket (14) from inlet housing (10) and discard,

INSTALL:

1. Clean mating surfaces of outlet and inlet thermostat housings and apply silicone sealant (Item 3, App. C).
2. Install gasket (14) on inlet thermostat housing (10) and O-ring (12) on outlet housing (13).
3. Install new thermostat element (11). Make sure element is firmly seated in inlet thermostat housing (10).
4. Aline bolt holes in inlet and outlet thermostat housings. On MK2, aline holes of mounting bracket (7) with holes in thermostat housings. Install washers (9) and bolts (8).
5. Tighten bolts using wrench.
6. Install thermostat housing assembly (4).
7. Connect three hoses and hose clamps (1,2 and 3).
8. Tighten hose clamps (1,2 and 3) using screwdriver.
9. On MK2, secure thermostat mounting bracket (7) to engine with washer (6) and bolt (5). Tighten using socket.
10. Refill fresh water cooling system on MK1 (refer to paragraph 3-68). Refill primary and secondary pooling systems on MK2 (refer to paragraph 3-69).

3-74. ENGINE OIL COOLER REPLACEMENT INSTRUCTIONS (PORT OR STARBOARD)

TOOLS: Flat Tip Screwdriver, 4 inch
 5/8 inch Open End Wrench
 14 mm Box Wrench
 Oil Filter Wrench
 3/4 inch Open End Wrench
 11/16 inch Open End Wrench

PARTS/MATERIALS: Oil Cooler Assembly
 Oil Filter
 Gasket
 Shallow Liquid Container
 Silicone Sealant
 Rags

REMOVE:

1. Open and secure battery hatch (refer to paragraph 3-154).
2. Open and secure engine hatches (refer to paragraph 3-154).
3. Remove buoyancy flotation material to replace starboard engine oil cooler (refer to paragraph 3-152).
4. Drain fresh water cooling system on MK1 (refer to paragraph 3-68). Drain primary and secondary cooling systems on MK2 (refer to paragraph 3-69).

MK1

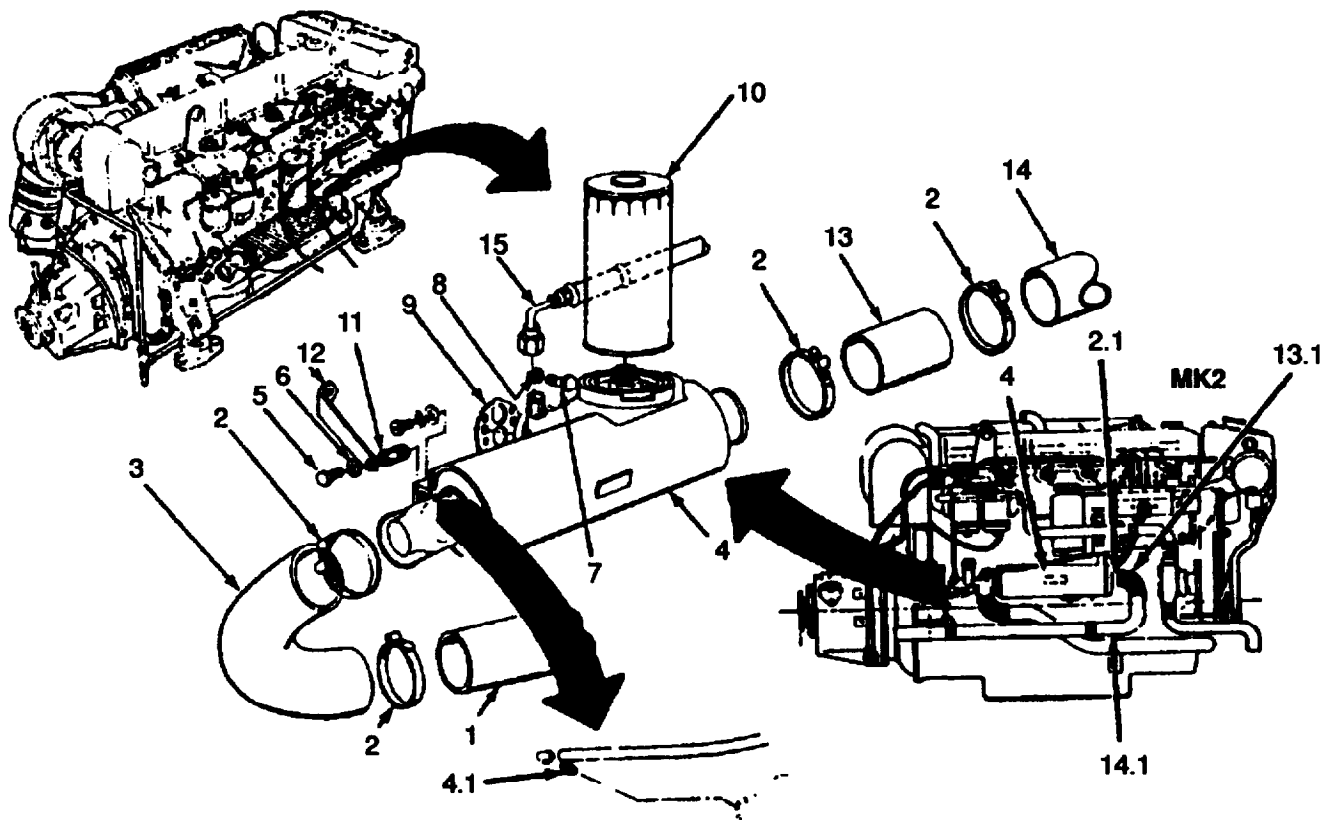

5. Using screwdriver loosen two clamps (2) securing rubber hose (3) to oil cooler (4) and pipe (1).
6. Using screwdriver loosen two hose clamps (2) securing straight hose (13) to pipe (14) and oil cooler (4) on MK1 . Using screwdriver loosen two hose clamps (2.1) securing 90° elbow hose (13.1) to pipe (14.1) and oil cooler (4) on MK2.
7. Move rubber hoses (3 and 13 on MK1 or 3 and 13.1 on MK2) away from ends of oil cooler(4).
8. Using 11/16 inch wrench remove hose fitting adapter (4.1) from end of oil cooler (4) on MK2.
9. Using 14 mm box wrench remove bolt (5) and washer (6) from bracket (12) and adapter plug (11).
10. Using oil filter wrench remove oil filter (10).
11. Using 3/4 inch open end wrench remove oil hose fitting (15).
12. Using 5/8 inch open end wrench remove two bolts (7) and washers (8) securing oil cooler flange and gasket (9) to engine.
13. Remove oil cooler (4).
14. Remove adapter plug (11) using 14 mm box wrench.
15. Using rags (Item 4, App. C) wipe up any oil or coolant that was spilled.

REPLACE:

1. Install oil filter (10) on oil cooler (4) and hand tighten only.
2. Install adapter plug (11) on oil cooler (4).
3. Coat new gasket (9) with silicone sealant (Item 3, App. C). Install on engine and align holes in engine block.
4. Place oil cooler (4) so flange is aligned with holes in gasket (9).
5. Install two washers (8) and bolts (7) and hand tighten bolts.
6. Using 5/8 inch open end wrench tighten two bolts(7).
7. Install oil hose fitting (15) and tighten using 3/4 inch open end wrench.
8. Install washer (6) and bolt (5) through bracket (12) in adapter plug (11) and tighten using 14 mm box wrench.
9. Using 11/16 inch open end wrench install hose fitting adapter (4.1) on end of oil cooler on MK2.
10. Push rubber hoses (3 and 13 on MK1 or 3 and 13.1 on MK2) on ends of oil cooler (4) beyond flare.
11. Using screwdriver tighten four hose clamps (2) on hoses (3 and 13 or 13.1).
12. Refill fresh water cooling system on MK1 (refer to paragraph 3-68). Refill primary and secondary cooling systems on MK2 (refer to paragraph 3-69).

3-75. ENGINE OIL COOLER REPAIR INSTRUCTIONS

TOOLS: Flat Tip Screwdriver, 4 inch
Oil Filter Wrench

PARTS/MATERIALS: Two O-rings
Oil Filter

REMOVE:

1. Remove engine oil cooler assembly from engine (refer to paragraph 3-74).

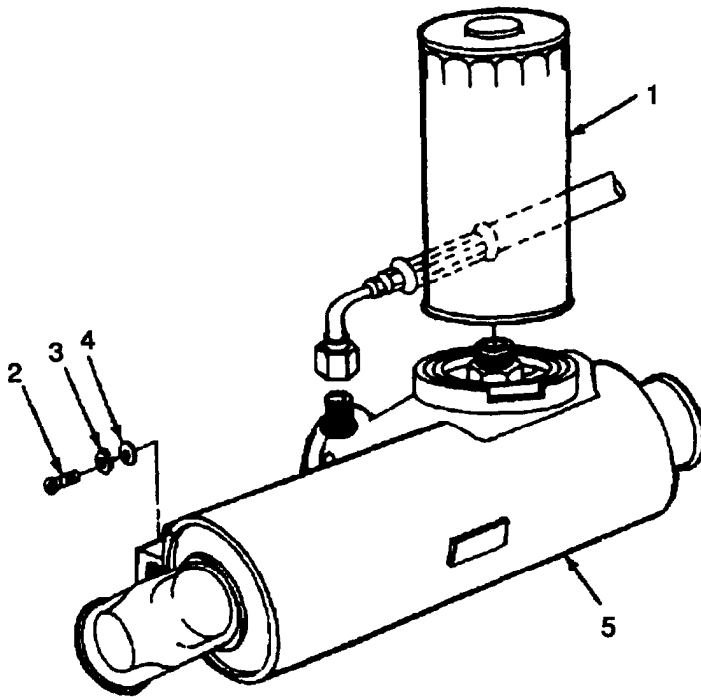

REPAIR:

1. Using oil filter wrench, remove oil filter (1).
2. Use screwdriver to remove screw (2), lockwasher (3) and washer (4) at each end of oil cooler (5).

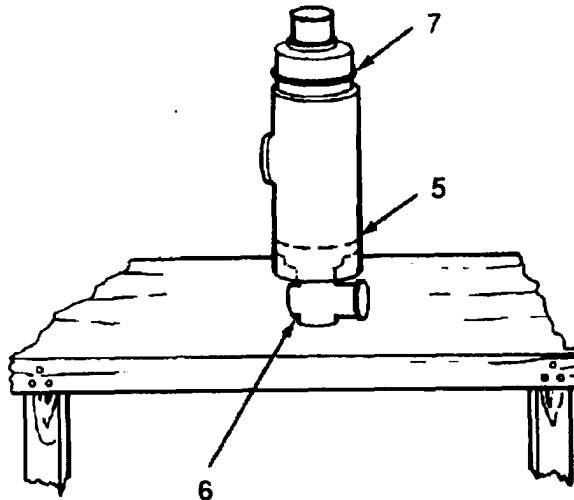

3. Standing oil cooler housing (5) upright, carefully tap L-shaped end of tube stack (6) into housing to fully expose O-ring (7) at opposite end.
4. Remove O-ring (7) from exposed end of tube stack (6) and discard.

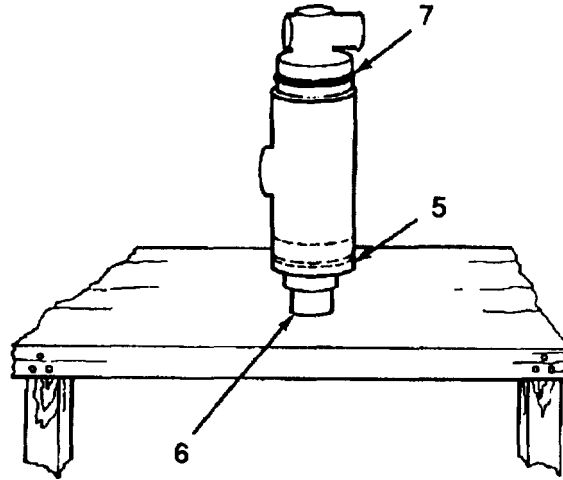

5. Carefully tap straight end of tube stack (6) into housing to fully expose O-ring (7) at opposite (L-shaped) end of tube stack (6).
6. Remove O-ring (7) from L-shaped end of tube stack (6) and discard.

NOTE

To replace O-rings (7) only, follow same procedure. Retain and reinstall tube stack (6).

7. Carefully slide tube stack (6) out of tube stack housing.
8. Check tube stack (6) for signs of cracks and mixture of oil and water.
9. Clean inside of oil cooler housing (5).
10. Coat O-ring (7) with engine oil and install on L-shaped end of replacement tube stack (6).
11. Slide replacement tube stack (6) through housing (5) beginning at non-filter end far enough to expose O-ring groove at opposite end.
12. Coat new O-ring (7) with engine oil and install on tube stack (6).
13. Align grooves on tube stack (6) with screw holes on housing (5).
14. Carefully tap tube stack (6) into housing (5).
15. Reinstall washer (4), lockwasher (3) and screws (2) at each end of oil cooler using screwdriver.
16. Install oil filter (1) on oil cooler (5). Hand tighten only.
17. Replace engine oil cooler assembly (refer to paragraph 3-73).

3-76. ENGINE OIL FILTER ELEMENT REPLACEMENT INSTRUCTIONS

TOOLS: Strap Wrench

PARTS/MATERIALS: Oil Filter Element
Shallow Liquid Container, Two Quart Capacity
Engine Oil
RAGS

REMOVE:

1. Open and secure engine hatches (refer to paragraph 3-154).

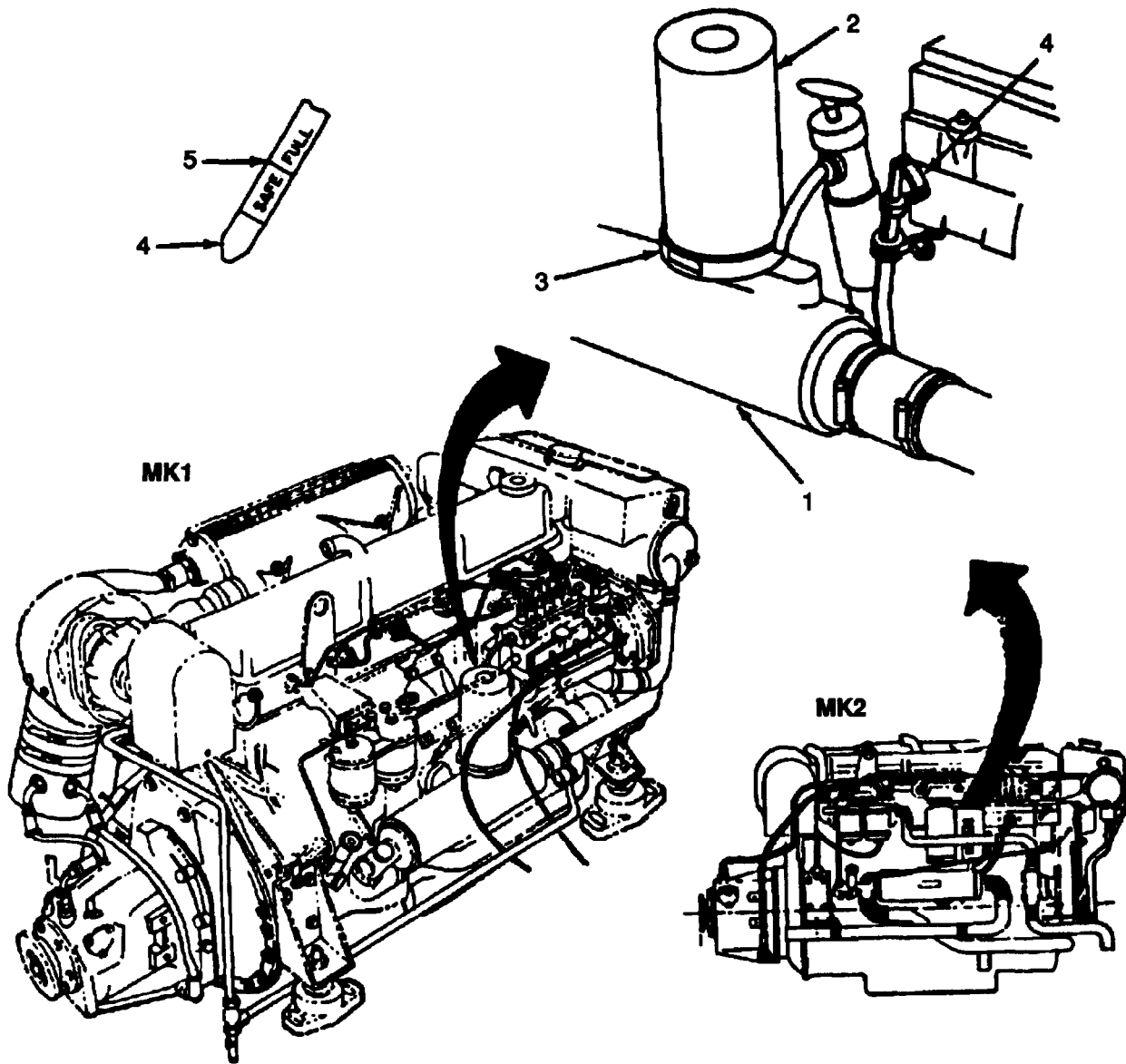

2. Place shallow liquid container under engine oil cooler (1) to catch oil from filter (2) during removal.
3. Using strap wrench remove oil filter element (2) and discard.
4. Wipe up spilled oil and discard oil in container.
5. Wipe oil from filter adapter (3) and ensure that no dirt falls into oil cooler (1) thru the filter opening.

INSTALL:

1. Smear new oil filter gasket and seat area on adapter with clean engine oil.
2. Screw new filter element (2) onto adapter (3) and hand tighten.
3. Wipe up spilled oil from filter element and oil cooler.
4. Check oil level on dipstick (4) and add oil until level reaches FULL mark (5).
5. Close engine hatches.

3-77. KEEL COOLER (FRONT AND REAR) REPLACEMENT INSTRUCTIONS (MK2)

TOOLS: 15/16 inch Combination Wrench

Putty Knife

Flashlight

2 1/2 inch Open End Wrench (Armstrong) 28-080

PARTS/MATERIALS: Keel Coolers

Silicone Sealant

Wire Brush

PERSONNEL REQUIRED: Two

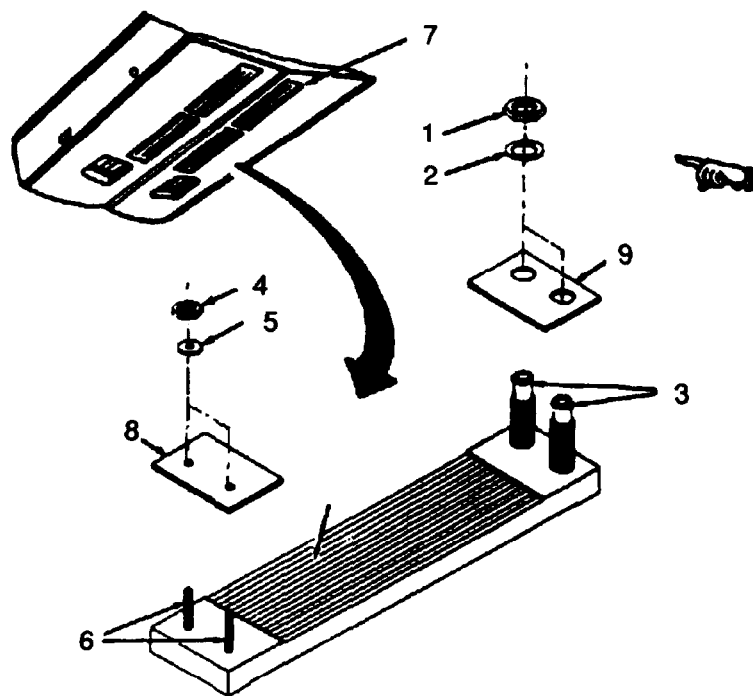

REMOVE:

CAUTION

A second person is required to support the keel cooler to prevent equipment damage when mounting hardware is removed.

Ensure that all keel cooler inlet/outlet pipes are covered to prevent foreign matter from entering pipes when keel cooler hoses are removed. Damage to equipment could result.

Ensure that the boat is firmly supported before working under it.

NOTE

There are four keel coolers in the boat. Two keel coolers are located under the aft compartment and two are located under the engine compartment.

1. Remove aft cockpit (refer to paragraph 3-27).
2. Open and secure engine compartment hatches (refer to paragraph 3-25).
3. Drain primary and secondary cooling systems (MK2) (refer to paragraph 3-69).
4. Remove keel cooler inlet/outlet hoses (refer to paragraph 3-68).
5. Using 2 1/2 inch open end wrench, remove two pipe nuts (1) and washers (2), from inlet and outlet pipes (3).
6. Using 5/16 inch combination wrench, remove two nuts (4) and washers (5), securing rear keel cooler front support studs (6).
7. With assistance of second person, lower keel cooler (7) out of keel cooler box.

CAUTION

Do not damage gasket mating surface when removing silicone sealant.

8. Using putty knife, remove two rubber gaskets (8) and (9) and silicone sealant.
9. Using wire brush, clean debris from cooler mounting hardware.

INSTALL:

1. Install rubber gasket (8) over cooler front support studs (6).
2. Install rubber gasket (9) over inlet and outlet pipes (3).
3. Apply silicone sealant, Item 3, App. C, to surface of rubber gaskets (8) and (9).
4. With assistance of second person, place keel cooler (7) in keel cooler box.
5. Install two washers (5), and nuts (4) securing rear keel cooler front support studs (6) and hand tighten.
6. Install two washers (2), and pipe nuts (1) on inlet and outlet pipes (3) and hand tighten.
7. Using 15/16 inch combination wrench, tighten two nuts (4).
8. Using 2 1/2 inch open end wrench, tighten two pipe nuts (1).
9. Replace keel cooler inlet/outlet hoses (refer to paragraph 3-68).
10. Replace coolant and check for leaks (refer to paragraph 3-69).

3-78. REMOTE COOLER INSPECTION AND REPLACEMENT INSTRUCTIONS (MK1 - PORT AND STARBOARD)

TOOLS: Flat Tip Screwdriver, 4 inch
1 inch Open/Box Wrench
7/8 inch Open End Wrench
1/2 inch Socket
Ratchet
3/16 inch Socket Head Screw Key
Putty Knife
Plastic Head Hammer

PARTS/MATERIALS: Remote Cooler, Tube Stack,
Drain Pan (Container), One Quart Capacity
Two O-rings, Silicone Sealant.

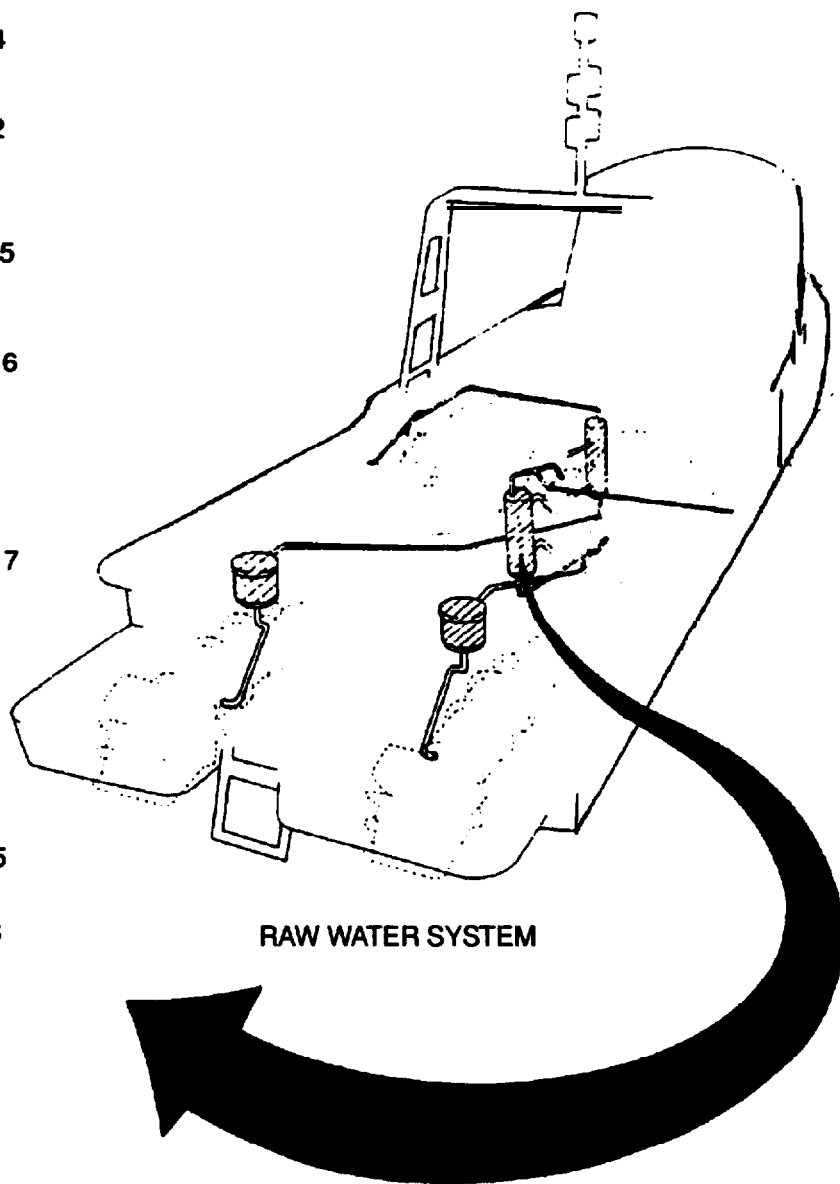
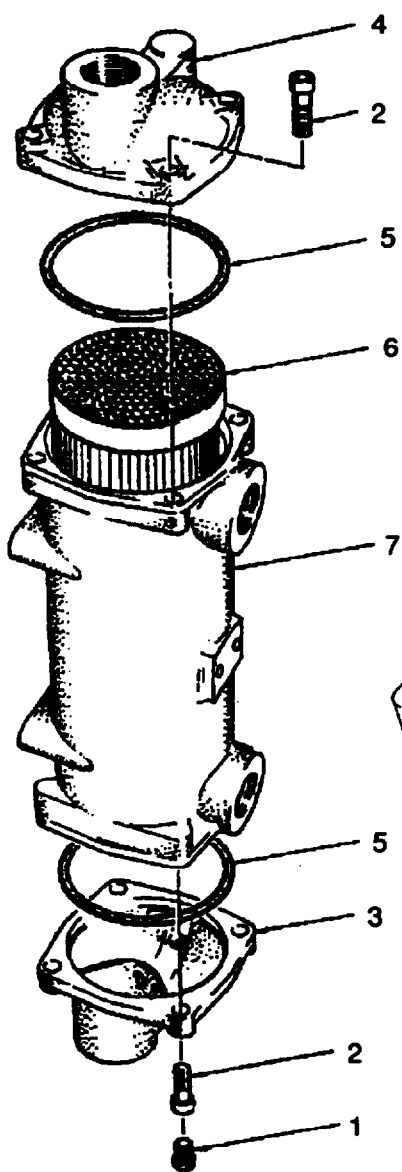

REMOVE :

1. Open and secure engine hatches (refer to paragraph 3-154).
2. Drain the cooling system (refer to paragraphs 3-68 and 3-69).
3. Disconnect pipework connecting the remote coolers to the rest of the engine cooling system.
4. The remote cooler for the port engine is located forward of the engines, mounted on a bracket fixed to the enter of the forward bulkhead of the engine compartment. Loosen and remove four mounting bolts to remove the cooler complete with its mounting bracket.
5. The remote cooler for the starboard engine is located aft of the engines, mounted on a bracket fixed by U-bolts to the upright tubular post at the rear of the engine compartment. Loosen and remove U-bolts to remove cooler on its mounting bracket.

DISASSEMBLY

1. Using socket head screw key remove eight socket head screws (2) from end covers (3 and 4).
2. Remove end covers (3 and 4).
3. Remove and discard O-rings (5).

CAUTION

Use only plastic head hammer to strike tube stack. Other hammers may cause damage to equipment.

4. Using plastic head hammer tap tube stack (6) to free it from cooler casing (7).
5. Slide tube stack (6) from cooler casing (7).
6. Using putty knife, dean mounting surface between casing (7) and end covers (3 and 4). Clean inside of casing (7).

INSPECT AND REPAIR:

1. Check tube stack (6) for signs of cracks and mixture of fluids.
2. Check tube stack (6) water passages for clogging. If any tube is clogged, clean (ream out) or replace tube stack.

ASSEMBLE:

1. Slide new tube stack (6) into cooler casing (7).
2. Coat new O-rings (5) with transmission oil and install over ends of tube stack (6).
3. Reinstall end covers (3 and 4) and eight socket head screws (2). Using socket and head screw key tighten socket head screws.

INSTALL:

1. Refer to the above REMOVE procedure and apply the steps in reverse order to reinstall both port and starboard remote coolers.

3-79. WATER PUMP INSPECTION INSTRUCTIONS (PORT OR STARBOARD ENGINE)
MK1 - COOLING SYSTEM PUMP
MK2 - SECONDARY WATER PUMP

TOOLS: Flat Tip Screwdriver, 4 inch
Putty Knife
Slip Joint Pliers

PARTS/MATERIALS: Gasket
Sealing Compound
Liquid Detergent

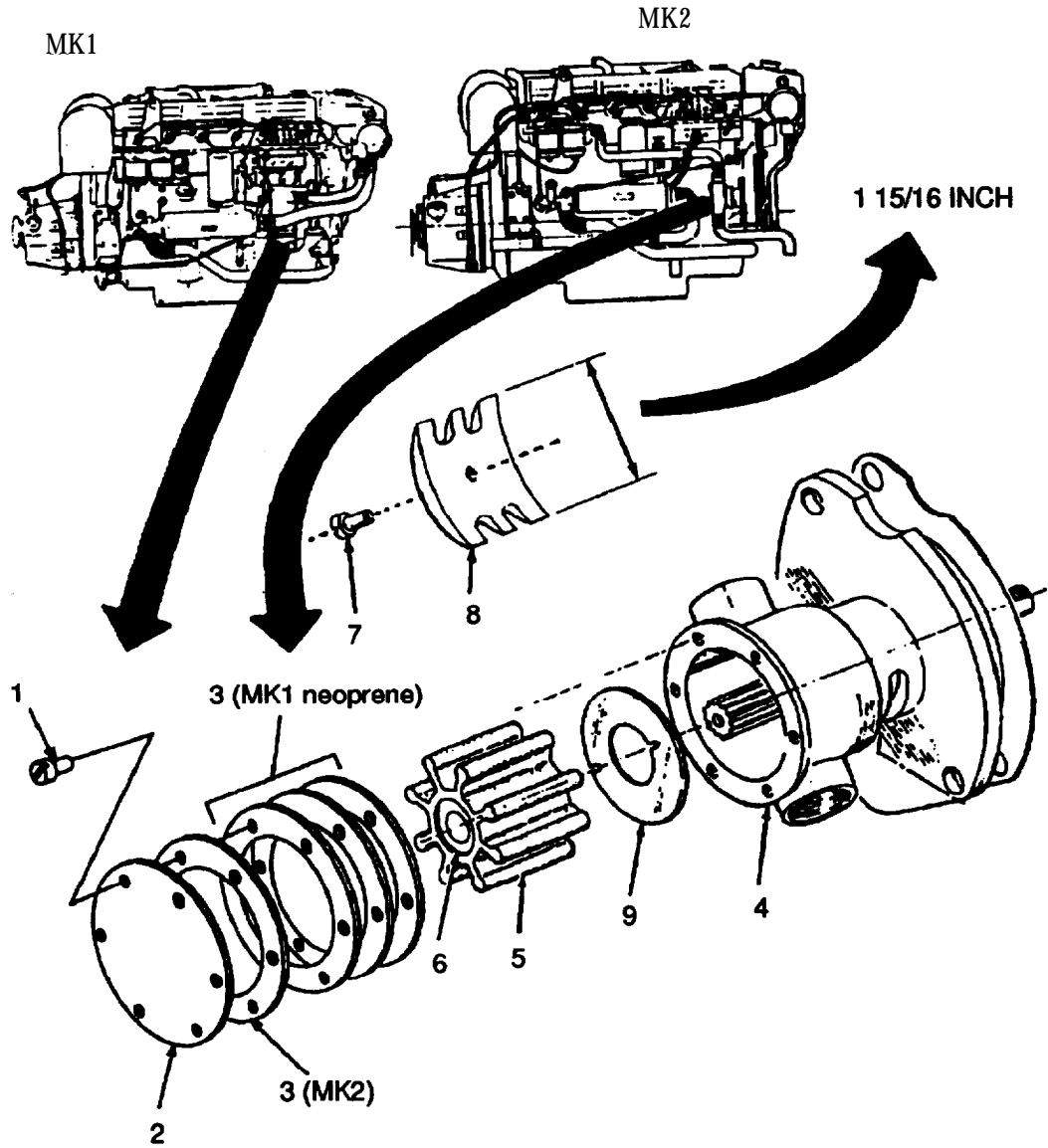

DISASSEMBLE:

1. Open and secure engine hatches (refer to paragraph 3-323).

NOTE

Buoyancy material must be removed to inspect starboard raw water pump (refer to paragraph 3-152).

2. Remove water pump (refer to paragraph 3-81).
3. Using screwdriver remove six screws (1) holding end plate (2).
4. Remove and clean end plate (2).
5. Remove gasket (3) from body (4).

NOTE

Observe the position of the impeller blades to aid in reassembly.

6. Using pliers, grasp blade on each side of impeller (5) and pull impeller off shaft.
7. Push screwdriver through impeller (5) open end to remove spline seal (6).
8. Remove cam retaining screw (7).
9. Withdraw cam (8) and wear plate (9) assembly from body (4).

INSPECT

1. Inspect impeller for:
 - a. Missing blade or portion of blade.
 - b. Blades permanently bent (will not return to proper shape).
 - c. Wear (blade missing small pieces or ragged in appearance).If any of the above conditions exist, replace impeller.
2. Inspect cam for wear as follows:
 - a. Check finger ends. They should not be worn to knife edge. If they are or are approaching knife edge, replace cam.
 - b. Finger ends should not be uneven, ragged, or rough to touch.
 - c. Distance (measured straight across) between opposing finger ends should not be less than 1-15/16 inch.If any of the above conditions exist, replace cam.
3. Inspect wear plate as follows:
 - a. Check for deep grooves in plate.
 - b. Check for wear to one-half original plate thickness.If either of above conditions exist, wear plate can be reversed unless it has been turned before. In that case, a new wear plate must be installed.

ASSEMBLE:

1. Fit wear plate (9) and cam (8) into body (4) as an assembly. Dowel or cam fits into hole in wear plate.
2. Using screwdriver, install cam retaining screw (7).
3. Rub thin film of liquid detergent (Item 5, App. C) on impeller (5) blades.
4. Fit impeller (5) on shaft and into body (4). If blades are bent to fit into body, make sure all are bent in same direction.
5. Push impeller (5) on shaft until flush with body (4).

6. Push spline seal (6) on end of impeller (5).
7. Coat both sides of new gasket (3) with sealing compound (Item 18, App. C).
8. Install gasket (3) and end plate (2) on body (4).
9. Using screwdriver, install six screws (1) holding end plate (2) and tighten evenly.
10. Replace buoyancy material if removed.
11. Replace water pump (refer to paragraph 3-81).
12. Close engine hatches (refer to paragraph 3-154).

3-80. WATER PUMP REPAIR INSTRUCTIONS
MK1 - COOLING SYSTEM PUMP
MK2 - SECONDARY WATER PUMP

TOOLS: Two Flat Tip Screwdrivers, 4 Inch
Putty Knife

PARTS/MATERIALS: Impeller with Button
Gasket
Sealing Compound
Liquid Detergent

REPAIR:

1. Open and secure engine hatches (refer to paragraph 3-154).

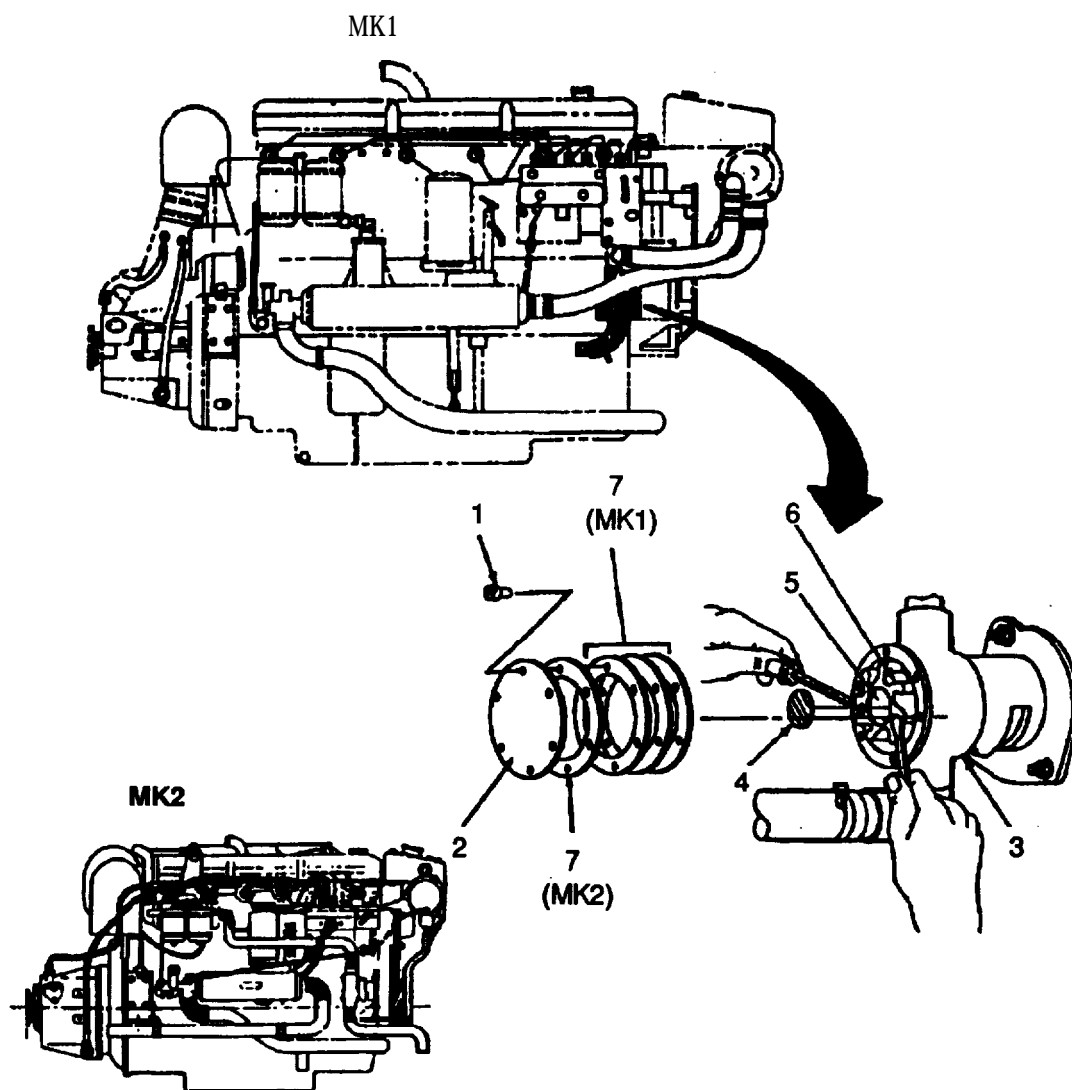

NOTE

Buoyancy material must be removed to repair starboard water pump (refer to paragraph 3-152).

2. To remove end plate (2) from pump (3) remove six screws (1) using screwdriver.

CAUTION

If impeller is damaged, check heat exchanger for particles of rubber (MK1) (see paragraph 3-71).

3. Remove end plate (2) and clean.
4. Remove gasket (7) from surface of end plate (2) and pump (3).
5. Using two screwdrivers remove button (4) and impeller (5) (note position in figure).

ASSEMBLE:

1. Rub vanes (6) of replacement impeller (5) with liquid detergent (Item 5, App. C) and water mixture.
2. Bend vanes (6) back and forth to fit into pump body (3).
3. Push impeller (5) on shaft until flush with pump body.
4. Push rubber button (4) on end of impeller (5) to seal the shaft.
5. Coat both sides of new gasket (7) with sealing compound (Item 18, App. C).
6. Install gasket (7) and end plate (2) on pump body.
7. Reinstall six screws (1) and tighten screws evenly using screwdriver.
8. Replace buoyancy material if removed from starboard side (refer to paragraph 3-152).
9. Close engine hatches.

3-81. WATER PUMP REPLACEMENT INSTRUCTIONS (PORT OR STARBOARD)

MK1 - COOLING SYSTEM PUMP

MK2 - SECONDARY WATER PUMP

TOOLS: Flat Tip Screwdriver, 4 inch
9/16 inch Box Wrench
11/16 inch Open End Wrench
Putty Knife
Snap Ring Pliers
Pipe Wrench
6 or 8 inch Pipe Wrench
9/16 inch Socket & Ratchet with 6 inch Extension

PARTS/MATERIALS: Pump
Gasket Sealing Compound
Pipe Tape

REMOVE:

1. Open and secure engine hatches (refer to paragraph 3-154).

NOTE

Buoyancy flotation material must be removed to remove the starboard pump.

2. Remove starboard flotation material if starboard water pump is to be removed (refer to paragraph 3-152).

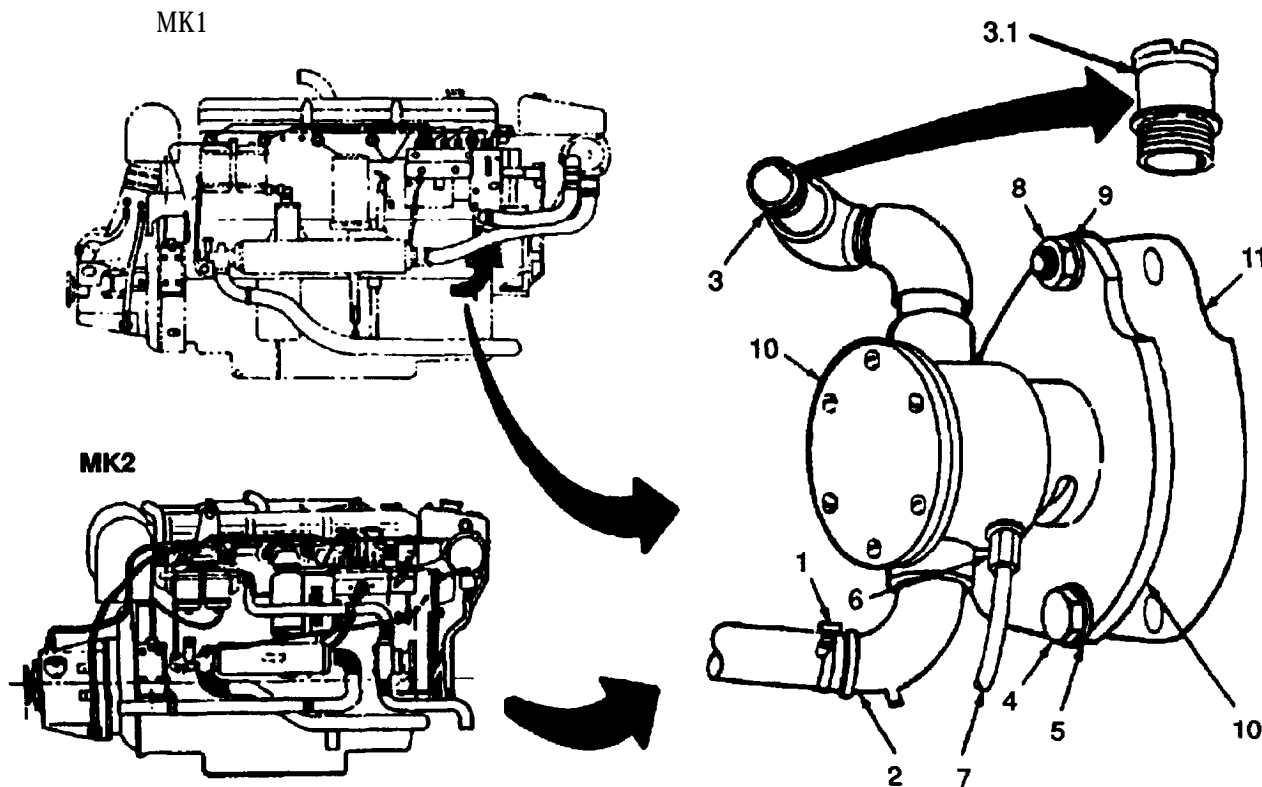

3. Using screwdriver loosen hose clamps (1) at 90° elbow pipes of MK1 or straight pipe (3.1) of MK2.
4. Twist hoses slightly to break seal and remove by pulling from pipes (2 and 3 or 3.1).
5. Using pipe wrench remove two 90° elbows (3) on MK1 or straight pipe (3.1) on MK2.
6. Using pipe wrench remove 90° elbow (2).
7. Using box wrench remove two butts (4) and washers (5).
8. Using 11/16 inch wrench loosen nut (6) and disconnect drain down tubing (7) on MK1.
9. Hold pump and use 9/16 inch socket and 6 inch extension and ratchet to remove nut (8) and washer (9).
10. Remove pump (10) and gasket (11). Discard gasket (11).

REPLACE:

1. Using putty knife clean old gasket material from engine housing.
2. Coat new gasket (11) with sealing compound (Item 18, App. C) on both sides and mount an stud in engine housing. Aline other two holes.
3. Mount pump (10) on engine.
4. Install two washers (5) and bolts (4) and tighten bolts using box wrench.
5. Install washer (9) and nut (8) and tighten nut using 9/16 inch socket and 6 inch extension and ratchet.
6. On MK1 install drain down tubing (7) and tighten nut (6) using 1 1/16 inch wrench.
7. Wrap threaded pips (2 and 3 or 3.1) with pipe taps (Item 2, App. C).
8. On MK1 install two 90° elbows (3) on pump (10) and tighten using pipe wrench. On MK2 install straight pips (3.1) on pump (10) and tighten using pipe wrench.
9. Install 90° elbow (2) on pump (10) and tighten using pipe wrench.
10. Install rubber hoses on elbow (2) and tighten hose clamp (1) using screwdriver.
11. Install rubber hose on elbow (3) or straight pipe (3.1) and tighten hose clamp (1) using screwdriver.
12. Replace buoyancy material if removed from starboard side (refer to paragraph 3-152).
13. Close engine hatches.

3-82. INTERCOOLER REPAIR INSTRUCTIONS (PORT AND STARBOARD)

TOOLS: 9/16 inch Box Wrench
Putty Knife
Plastic Head Hammer

PARTS/MATERIALS: Tube Stack
Two O-rings
Silicone Sealant

REMOVE:

1. Remove intercooler (refer to paragraph 3-83).

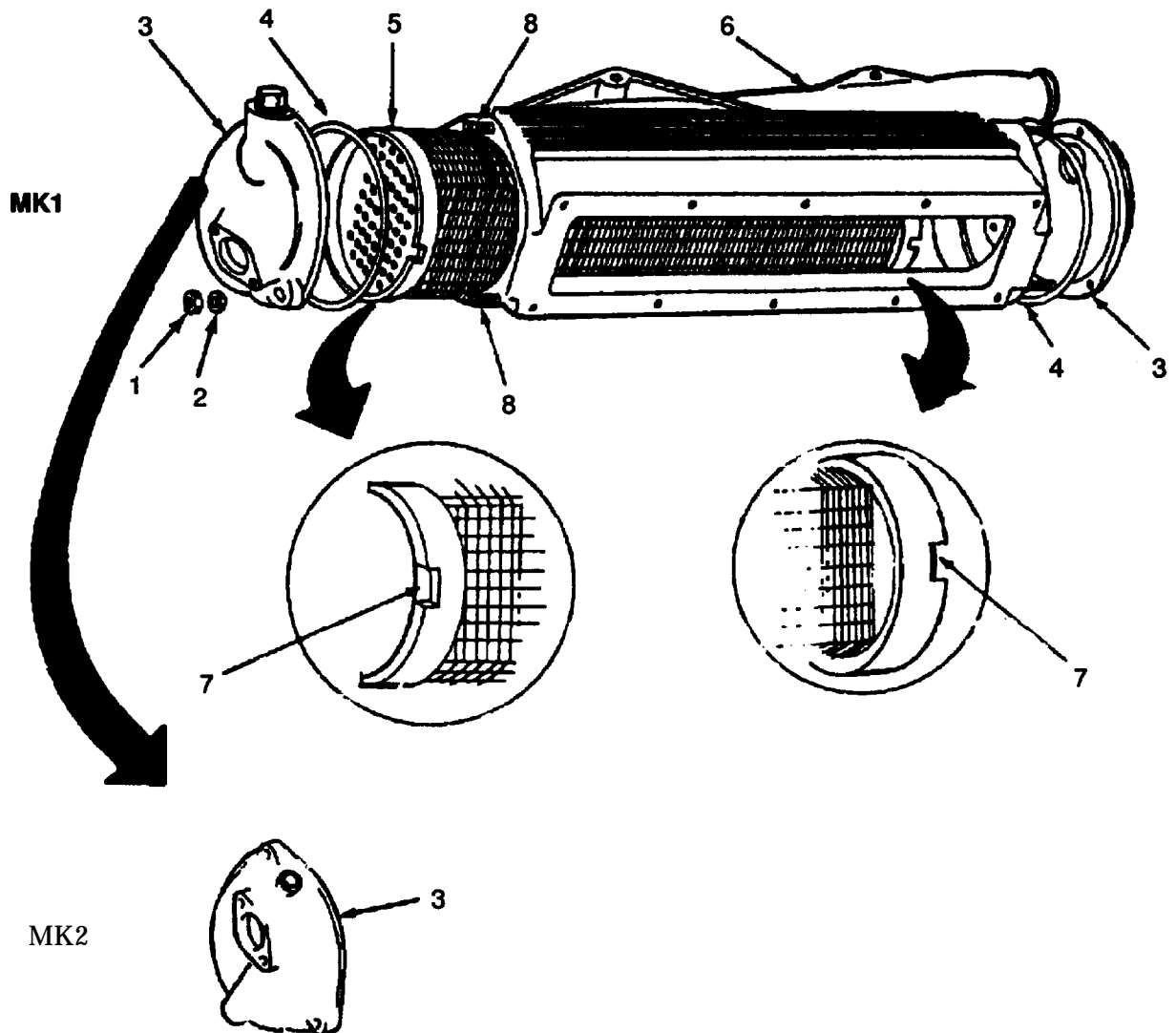

DISASSEMBLE:

1. Remove six nuts (1) and washers (2) from end covers (3) using wrench.

NOTE

Left end covers on MK1 and MK2 are positioned differently. Mark intercooler end covers before removal so they can be replaced in correct position.

2. Remove end covers (3).
3. Remove and discard O-rings (4).
4. Tap tube stack (5) with plastic head hammer to free it from intercooler casing (6).
5. Slide tube stack (5) from intercooler casing (6).
6. Clean mounting surfaces between casing (6) and end covers (6) using putty knife.
7. Clean interior of intercooler casing (6).

INSPECT AND REPAIR:

1. Inspect tube (5) stack tubes for cracks, breaks, or deformation of fins. If tubes are cracked or broken or if fins are deformed replace tube stack
2. Inspect tuba (5) stack water passages for clogging. If any tube is clogged replace the tubs stack.

ASSEMBLE:

1. Slide new tube stack (5) into intercooler casing (6). Insure notches (7) on tube stack face center of intake duct.
2. Coat O-rings (4) with silicone sealant (Item 3, App. 5) and install over ends of tubs stack (5).
3. Reinstall end covers (3), six washers (2) and nuts (1) on studs (8).
4. Tighten nuts (1) with wrench.

INSTALL:

1. Install intercooler (refer to paragraph 3-83).

3-83. INTERCOOLER REPLACEMENT INSTRUCTIONS (PORT AND STARBOARD)

TOOLS: Flat Tip Screwdriver, 4 inch
1/2 inch Box Wrench
5/8 inch Box Wrench
11/16 inch Open End Wrench
Putty Knife
9/32 in. Box Wrench

PARTS/MATERIALS: Intercooler Assembly
Gasket, Intercooler Stub Pipes, Two Each
Silicone Sealant

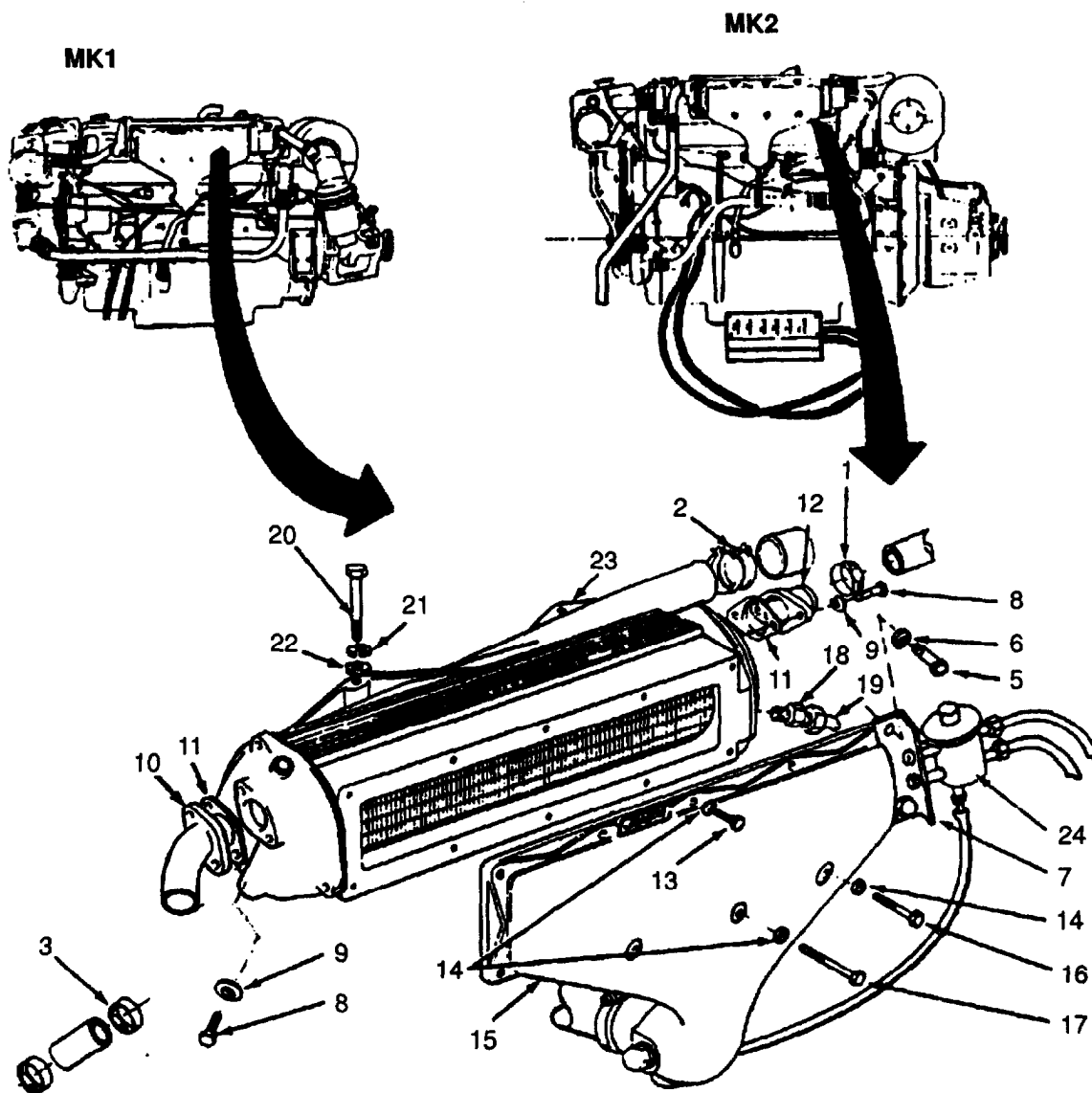

REMOVE:

1. Open and secure engine hatches (refer to paragraph 3-154).
2. Using 9/32 in. box wrench loosen hose clamps (1, 2 and 3).
3. Remove hoses from intercooler connections.
4. Using 1/2 inch box wrench remove two bolts (5) and washers (6) from reservoir bracket (7).
5. Using 1/2 inch box wrench remove four bolts (8) and washers (9) from both ends of intercooler assembly.
6. Remove thermostart fuel reservoir (24) (refer to paragraph 3-107).
7. Remove front stub pipe (10) and gasket (11). Discard gasket.
8. Clean mounting surface of front stub pipe (10) using putty knife.
9. Remove rear stub pipe (12) and gasket (11). Discard gasket.
10. Clean mounting surface of stub pipe (12) using putty knife.
11. Using 1/2 inch box wrench remove eight bolts (13) and washers (14) from intercooler duct (15).
12. Using 1/2 inch box wrench remove two bolts (16) and washers (14) from intercooler duct (15).
13. Using 1/2 inch box wrench remove bolt (17) and washer (14) from intercooler duct (15).
14. Using 11/16 inch wrench loosen nut (18) and disconnect drain down tubing (19) on MK1.
15. Using 5/8 inch box wrench remove two bolts (20) lockwashers (21) and flat washers (22) from intercooler assembly (23).
16. Remove intercooler assembly (23) from engine.
17. Clean intercooler duct (15).

INSTALL:

1. Install replacement intercooler assembly (23) on engine.

CAUTION

Support intercooler until steps 2 and 3 have been completed.

2. Secure intercooler by installing two flat washers (22), lockwashers (21) and bolts (20).
3. Tighten bolts (20) using 5/8 inch wrench.
4. Reinstall washer (14) and bolt (17) thru intercooler duct (15) into intercooler assembly (23).
5. Reinstall four washers (14) and bolts (13) thru intercooler duct (15) into intercooler assembly (23). Finger tighten.
6. Reinstall two washers (14) and bolts (16) through intercooler duct (15) into intercooler assembly (23). Finger tighten.
7. Install lockwashers (6) and bolts (5) thru reservoir bracket (7) into intercooler assembly (23). Hand tighten.
8. Using 1/2 inch wrench evenly tighten bolts (17, 13, 16, and 5).
9. Coat new gaskets (11) with sealant (Item 3, App. C) on both sides.
10. Install new gaskets (11) on ends of intercooler assembly (23).
11. Reinstall rear stub pipe (12), washers (9) and bolts (8). Tighten bolts using 1/2 inch wrench.
12. Reinstall front stub pipe (10), washers (9), and bolts (8). Tighten bolts using 1/2 inch wrench.
13. Install thermostart fuel reservoir (24) (refer to paragraph 3-107).
14. Reconnect drain down tube (19) on MK1. Using 11/16 inch wrench tighten nut.
15. Reinstall hoses to intercooler connections.
16. Position clamps (1, 2, and 3) and tighten using 9/32 inch box wrench.
17. Close engine hatches.

3-84. TRANSMISSION OIL COOLER INSPECTION AND REPAIR INSTRUCTIONS

TOOLS: 3/16 inch Socket Head Screw Key
Putty Knife
Plastic Head Hammer

PARTS/MATERIALS: Tube Stack
Two O-rings
Transmission Oil

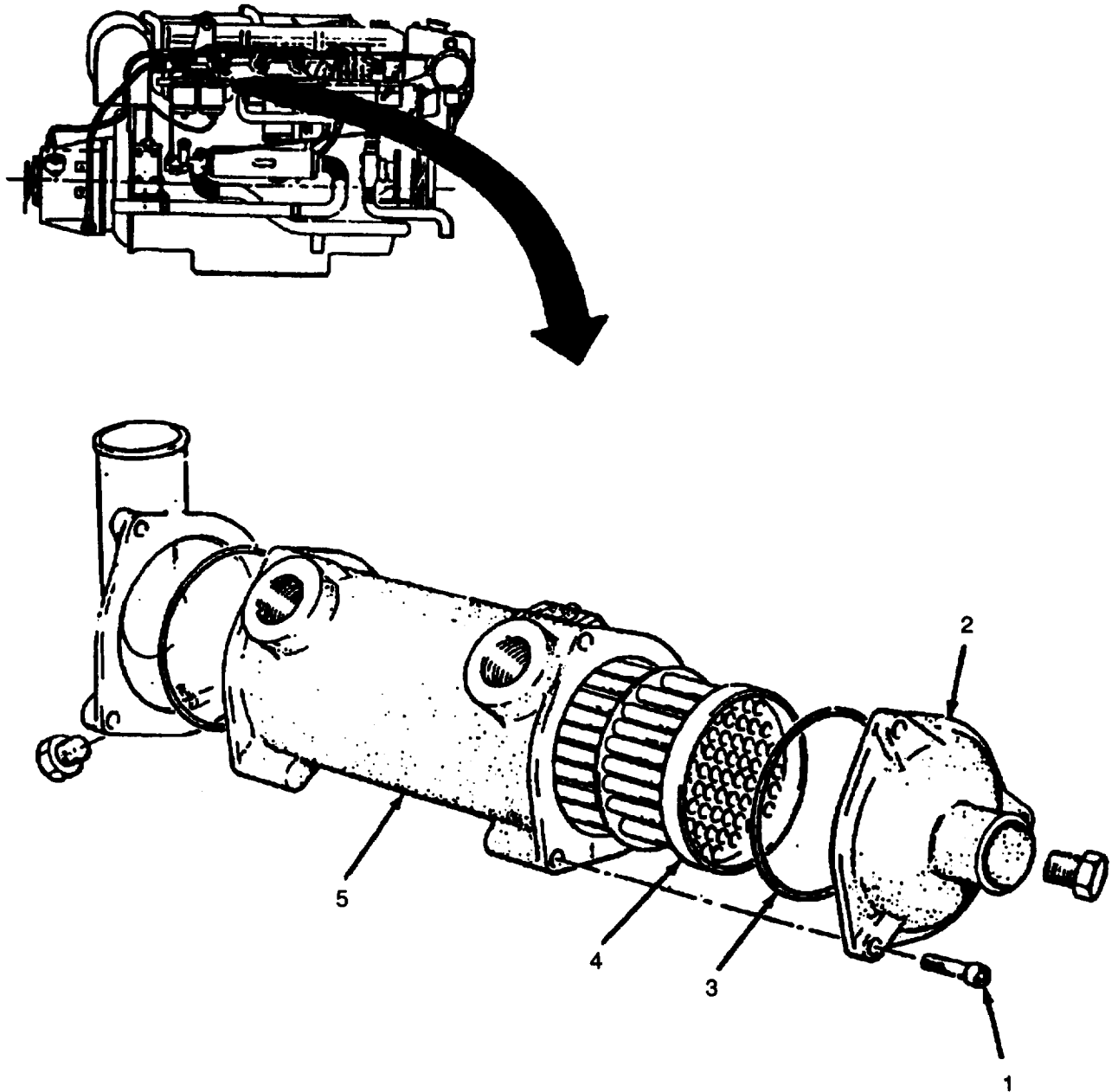

REMOVE:

1. Remove transmission oil cooler (refer to paragraph 3-65).

DISASSEMBLE:

1. Using socket head screw key remove six socket head screws (1) from end covers (2).
2. Remove end covers (2).
3. Remove and discard O-rings (3).

CAUTION

Use only plastic head hammer to strike tube stack. Other hammers may cause damage to equipment.

4. Using plastic head hammer tap tube stack (4) to free it from transmission oil cooler casing (5).
5. Slide tube stack (4) from transmission oil cooler casing (5).
6. Using putty knife clean mounting surfaces between casing (5) and end covers (2).
7. Clean inside of transmission oil cooler casing (5).

INSPECT AND REPAIR:

1. Check tube stack (4) for signs of cracks and mixture of transmission oil and water.
2. Check tube stack (4) water passages for clogging. If any tube is clogged replace tube stack.

ASSEMBLE

1. Slide new tube stack (4) into transmission oil cooler casing (5).
2. Coat new O-rings (3) with transmission oil (Item 6, App. C) and install over ends of tube stack (4).
3. Reinstall end covers (2) and six socket head screws (1).
4. Using socket and head screw key tighten socket head screws.

INSTALL:

1. Install transmission oil cooler (refer to paragraph 3-65).

3-85. TRANSMISSION OIL COOLER REPLACEMENT INSTRUCTIONS

TOOLS: Flat-Tip Screwdriver
7/8 inch Open End Wrench
1 inch Open End Wrench

PARTS/MATERIALS: Transmission Oil Cooler Assembly
Shallow Liquid Container
Silicone Sealant
Rags
Engine Oil

REMOVE:

1. Open and secure engine hatches (refer to paragraph 3-154).
2. Remove buoyancy material to replace starboard engine transmission oil cooler (refer to paragraph 3-152).
3. Drain the cooling system (refer to paragraph 3-69).

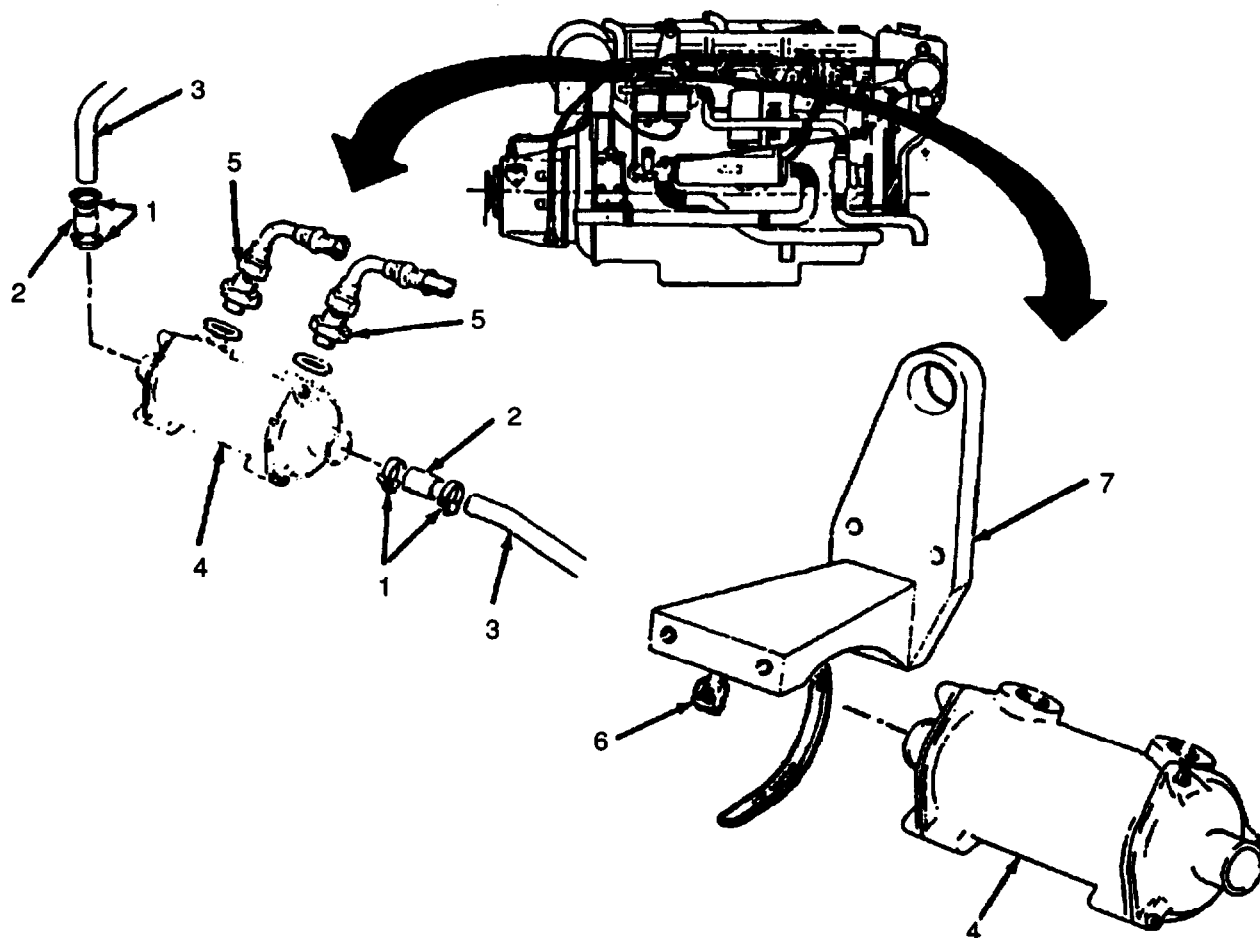

- 4 . Using screwdriver loosen four hose clamps (1) securing rubber hoses (2) to pipes (3) and transmission oil cooler (4).
5. Move rubber hoses (2) away from transmission oil cooler (4).
6. Using wrenches remove two transmission oil hose fittings (5) from transmission oil cooler (4). Hold liquid container under hose fittings while removing to catch transmission oil.
7. Using screwdriver loosen clamp (6) securing transmission oil cooler (4) to mounting bracket (7).
8. Slide transmission oil cooler (4) out of clamp (6) and mounting bracket (7) being careful not to spill transmission oil.
9. Using rags (Item 4, App. C) wipe up any transmission oil or coolant that was spilled.

REPLACE:

1. Slide new transmission oil cooler (4) into clamp (6) and mounting bracket (7).
2. Using screwdriver tighten clamp (6).
3. Install two oil hose fittings (5) and tighten using wrenches.
4. Push rubber hoses (2) on ends of transmission oil cooler (4) beyond flare.
5. Using screwdriver tighten four hose clamps (1) on hoses.
6. Refill cooling systems (refer to paragraph 3-69).
7. Replace buoyancy material (refer to paragraph 3-152) if removed.
8. Check transmission oil level with engine hot (refer to TM 5-1946-277-10). Add transmission oil as needed.
9. Close engine hatches.

3-86. INTAKE STRAINER (MK1) REPLACEMENT INSTRUCTIONS.

TOOLS: None

PARTS/MATERIALS: Intake Strainer

REMOVE:

NOTE

This procedure is applicable to the port and starboard raw water intake strainers and may be done in or out of water.

1. Open and secure hydrojet hatches (refer to paragraph 3-154).
2. Unclip retaining clamp (1).
3. Remove rim and lid (2).
4. Pull out strainer element (3).
5. Clean element as required.
6. Check that O-rings (4) are not damaged. Replace if necessary.

INSTALL:

1. Push clear element (3) back into body of strainer.
2. Replace lid (2).
3. Close retaining clamp (1).
4. Close hydrojet hatches.

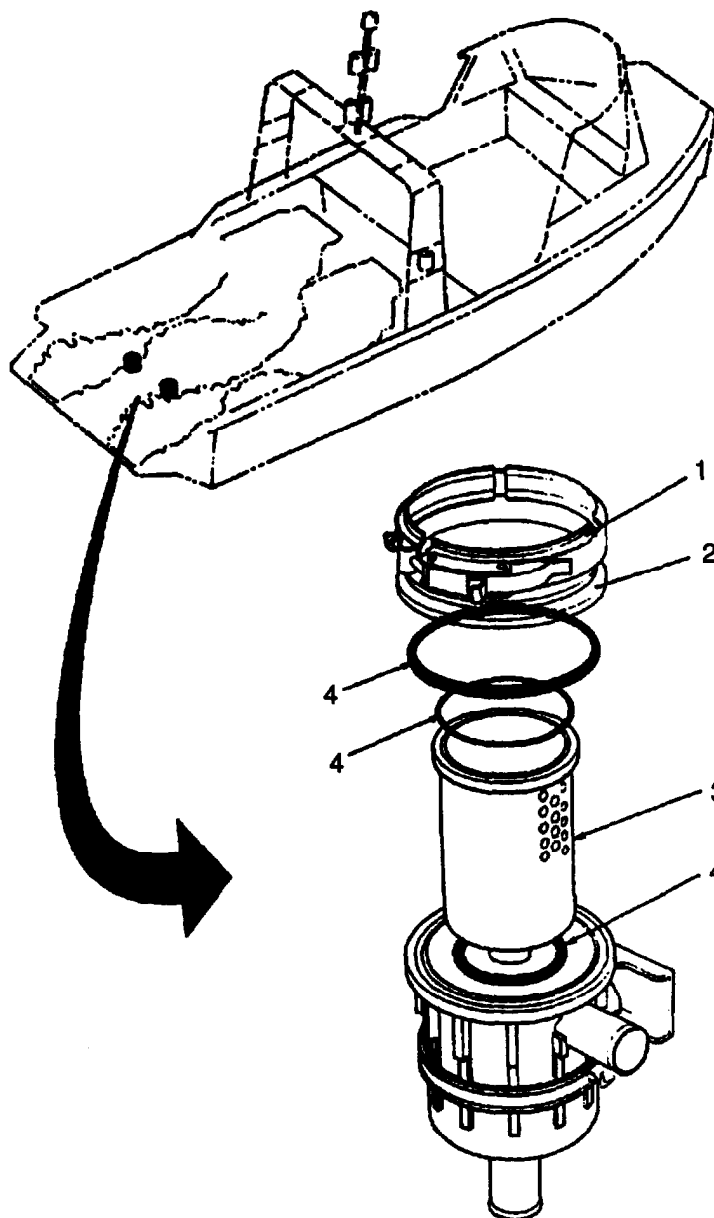

3-87. SLAVE STARTING INSTRUCTIONS.

TOOLS: 10 mm Box Wrench
Terminal/Post Cleaner
Wire Brush

PARTS/MATERIALS: NATO Slave Cable
MK1 NATO Adapter
Distiller Water
Baking Soda
Water
Eye Goggles
Rubber/Protective Gloves
GAA Grease
Rags

Reference: TM 9-6140-200-14

Preparation:



WARNING

- **Battery gases can explode. Do not smoke, have open flames, or make sparks around batteries. Batteries always vent gases. Battery can explode and cause injury.**
- **Electrolyte (battery fluid) and battery corrosion can cause injury to you. Wear safety goggles and gloves. Flush clothing and skin with clear water if electrolyte or battery corrosion is contacted. See a doctor if on face or in eye.**

1. Read slaving procedure before attempting slave starting.
2. Open and secure battery hatch (TM 5-1940-277-10).
3. Disconnect strap (1) securing battery box cover (2).
4. Remove battery box cover (2).

NOTE

Correct electrolyte level is at bottom of vent plug holes (filler caps). The electrolyte must be between top of plates and bottom of vent plug hole for this procedure. Do not overfill the battery.

5. Remove battery vent caps (1). Make sure vent holes in bottom of battery vent caps (3) are clean and open so gases can escape.

CAUTION

Battery plates must be covered with electrolyte (battery fluid).

NOTE

Use distilled water or a good grade drinking water (excluding mineral water).

6. Check level of electrolyte (1) in all cells (2) of batteries (3). Fill low cells to full level (4) with distilled water. Install battery vent caps (5).
7. Make sure battery cable connections (1) are clean and tight; clean and tighten as required.
8. Loosen nut and bolt on battery terminals (1) using 10 mm box wrench.
9. Remove battery cables (2) - negative first, positive second.
10. Remove battery (3) from battery box (4).

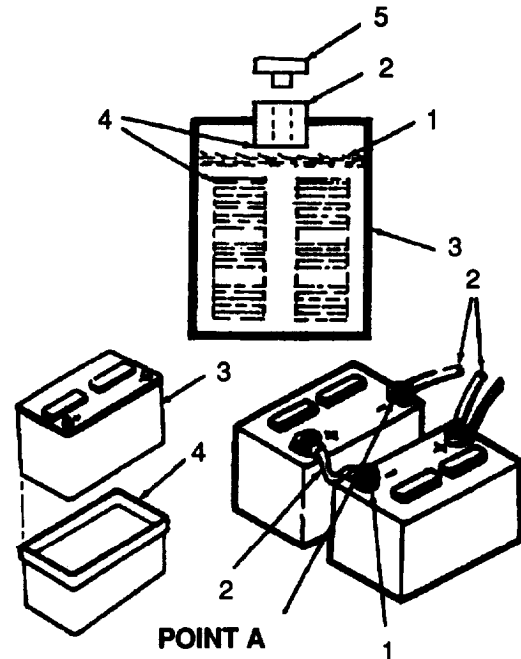

CAUTION

- Do not allow cleaning solution to spill on deck or any boat components. Damage to aluminum will result.
 - Ensure battery vent caps are on tight. Electrolyte will be neutralized if contaminated with cleaning solution.
11. Clean battery cable clamps inside battery box and cover using mixture of baking soda and water (1/2 pound of soda to 1 gallon of water).
 12. Pour mixture on or dip parts to be cleaned. Scrub with soft brush until foaming stops. Flush with clean water.
 13. Remove heavy corrosion buildup from terminals with terminal/post cleaner or wire brush.
 14. Position battery (3) in battery box (4).
 15. Connect battery cable terminals (1) (positive first, negative last) on battery post and tighten using 10 mm box wrench.
 16. Coat terminals with light coat of GAA grease.
 17. Have boat operator check the master switch and engine circuit switches to ensure switches are in off position and throttle and transmission control levers are in neutral position (TM 5-1940-277-10).
 18. Have vehicle operator place the vehicle transmission in neutral; set the parking brake; and ensure master switch is in OFF position.

NOTE

Use NATO slave cable. To adapt NATO slave cable to a 2-prong receptacle, use NATO adapter.

19. Connect slave cable to slave receptacle on vehicle: refer to vehicle TM for location of slave receptacle.
20. Remove slave receptacle cover (1). Connect slave cable to slave receptacle (2).

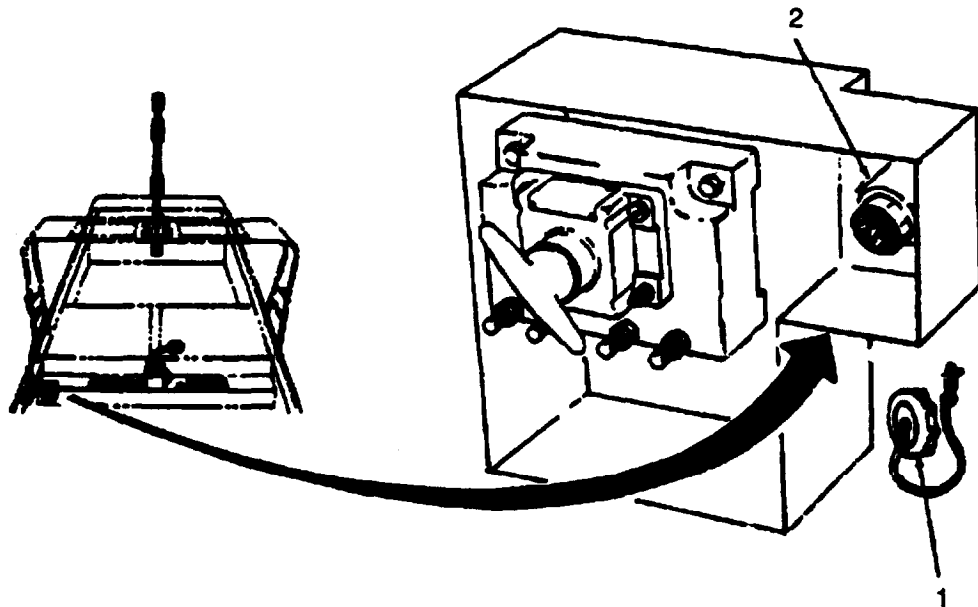

CAUTION

Do not disconnect slave cable while starter is cranking because this bums the cable and receptacle contacts.

21. Have vehicle operator start engine and run engine at fast idle (1000 to 1200 RPM) to charge dead batteries. Charge for 3 - 5 minutes.
22. Have boat operator turn master switch on and check port battery condition meter. When the system voltage reads 24 - 25.4 Vdc, batteries are fully charged (TM 5-1940-277-10).

CAUTION

Do not start MK1 boat out of water unless external water supply is used.

23. Have boat operator start engines and run at fast idle (1000 - 12000 RPM) (TM 5-1940-277-10).
24. Have vehicle operator turn vehicle master switch off.
25. Have boat operator turn boat master switch off.
26. Disconnect slave cable from slave receptacles on vehicles and boat.
27. Have vehicle and boat operators turn master switches on and run engines at 1000 RPM to build up rundown batteries (3 - 5 minutes).

3-88. BATTERY TESTING INSTRUCTIONS

TOOLS: Optical Antifreeze/Battery Tester
Multimeter
10 mm Box Wrench

PARTS/MATERIALS: Distilled Water
Rags

REFERENCE: TM 9-6140-200-14 for care and maintenance of lead-acid batteries.

TEST: Using Optical Battery Tester

WARNING

- Battery gases can explode. Do not smoke, have open flames, or make sparks around batteries. Batteries always vent gases. Battery can explode and cause injury.
- Electrolyte (battery fluid) and battery corrosion can cause injury to you. Wear safety goggles and gloves. Flush clothing and skin with clear water if electrolyte or battery corrosion is contracted. See a doctor if on face or in eye.

NOTE

Correct electrolyte level is at bottom of vent plug holes (filler caps). The electrolyte must be between top of plates and bottom of vent plug hole for this test. Do not overfill the battery.

NOTE

The 6TN and 6TL batteries can be mixed or matched. However, maintenance-free batteries cannot be mixed or matched with military batteries. The 6TN and/or the 6TL batteries will perform properly in hot weather as long as electrolyte levels are carefully monitored. If the electrolyte expands and causes the level to rise, some fluid must be removed. If the level becomes too low due to evaporation, distilled water may be used to obtain the proper level. A good grade of drinking water (excluding mineral waters) may be used if distilled water is not available.

Electrolyte (NSNs 6810-00-249-9354 and 6810-00-843-1640) have a specific gravity of 1.280 and should be used in these batteries. Do NOT adjust the electrolyte in wet batteries to a lower specific gravity.

1. Open and secure battery hatch (refer to paragraph 3-154).
2. Remove battery box cover (refer to paragraph 3-89, steps 2 and 3).
3. Remove caps from each battery cell.

NOTE

Check battery tester each time it is used for proper operation. To check, put several drops of clean water on window and check the shaded area through eyepiece. Window must be tight for correct reading. Tester is ok, if shading begins at +30° to +34°F. Dry the window after check.

4. Use black dipstick to get fluid from battery cell.

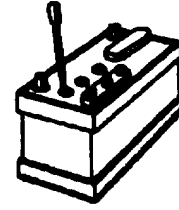

5. Place end of black dipstick in opening of window cover, deposit a few drops on measuring window. Repeat if necessary.

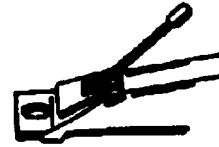

6. Holding tester with eyepiece at your eye look at bright light.

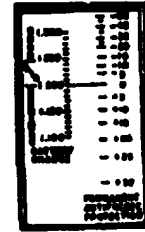

7. Read specific gravity (battery charge) at point between shaded and unshaded areas. (Full charged 1.280, not more than 0.025 difference between cells.)

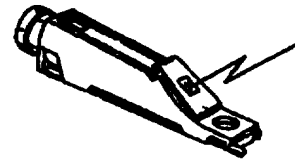

8. Use cloth to clean and dry measuring window and cover after testing each battery cell.

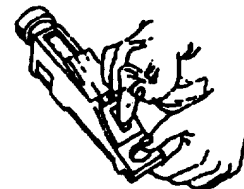

9. Repeat steps 4 thru 8 for each cell.
10. Repeat steps 4 thru 8 for any cell that has low reading.
11. Replace caps on each battery cell.
12. If specific gravity is low (less than 1.225) replace battery.

TEST: Using Multimeter

13. Set multimeter selector switch to voltage range higher than 24 Vdc.
14. Place red probe (+) on positive (+) post of right battery and black probe (-) on negative (-) post of left battery (note cable connection).

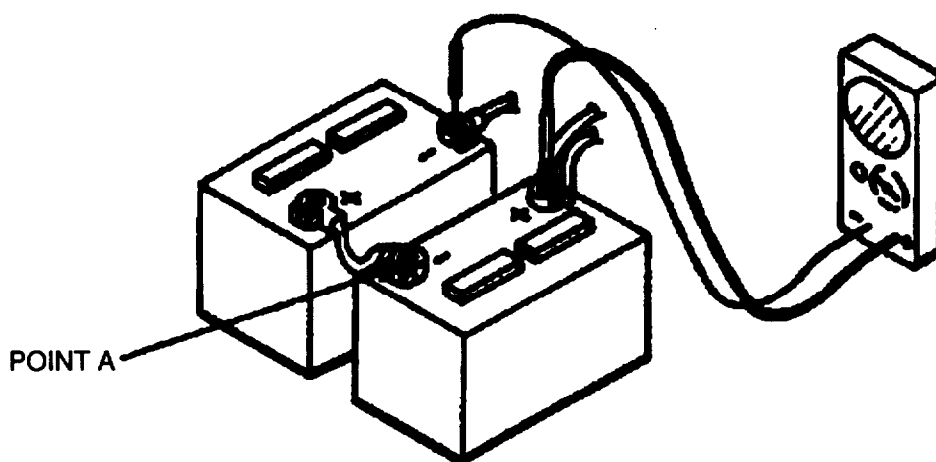

15. Read indicated voltage on meter. If 24 volts both batteries are ok.
16. If voltage is less than 24 volts, disconnect negative (-) terminal at point "A" using wrench.
17. Test voltage for each battery. Place probes on positive and negative posts.
18. Voltage reading for each battery is 12 volts.
19. If one battery voltage is low it must be replaced.
20. Connect batteries using wrench if disconnected for test.
21. Replace battery box cover (refer to paragraph 3-69).
22. Close battery hatch.

3-89. BATTERY REPLACEMENT INSTRUCTIONS

TOOLS: 10 mm Box Wrench
Soft Brush
Terminal/Post Cleaner
Wire Brush

PARTS/MATERIALS: Replacement Battery
Baking Soda
Water
Eye Goggles
Rubber/Protective Gloves
GAA Grease

REFERENCE: TM 9-6140-200-14

REMOVE:

WARNING

- Battery gases can explode. Do not smoke, have open flames, or make sparks around batteries. Batteries always vent gases. Battery can explode and cause injury.
- Electrolyte (battery fluid) and battery corrosion can cause injury to you. Wear safety goggles and gloves. Flush clothing and skin with clear water if electrolyte or battery corrosion is contacted. See a doctor if on face or in eye.

NOTE

The 6TN and 6TL batteries can be mixed or matched. However, maintenance-free batteries cannot be mixed or matched with military batteries. The 6TN and/or the 6TL batteries will perform properly in hot weather as long as electrolyte levels are carefully monitored. If the electrolyte expands and causes the level to rise, some fluid must be removed. If the level becomes too low due to evaporation, distilled water may be used to obtain the proper level. A good grade of drinking water (excluding mineral waters) may be used if distilled water is not available.

Electrolyte (NSNs 6810-00-249-9354 and 6810-00-843-1640) have a specific gravity of 1.280 and should be used in these batteries. Do NOT adjust the electrolyte in wet batteries to a lower specific gravity.

1. Open and secure battery hatch (refer to paragraph 3-154).

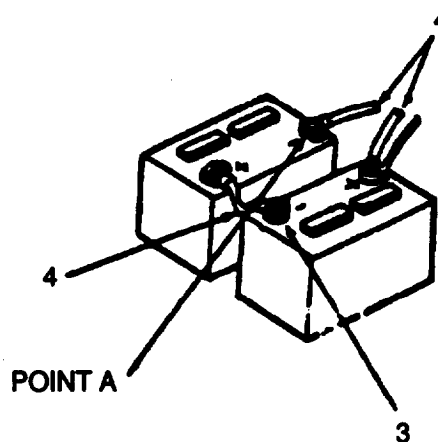
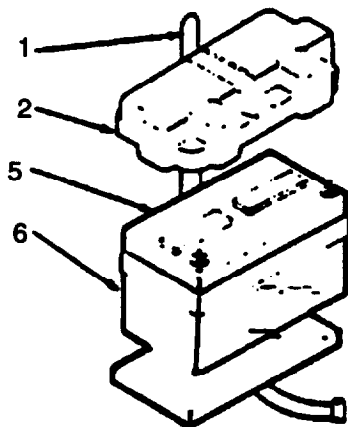

2. Disconnect strap (1) securing battery box cover (2).
3. Remove battery box cover (2).
4. Loosen nut and bolt (3) on battery terminals using 10 mm box wrench.
5. Remove all cables (4) from battery beginning with (A) negative cable first.
6. Remove battery (5) from battery box (6).

CAUTION

Do not allow the cleaning solution to spill on the deck or any other boat components. Damage to the aluminum will result.

7. Clean battery cable clamps, inside of battery box and cover. Use a mixture of bicarbonate of soda (baking soda) and water (1/2 pound soda to 1 gallon of water).
8. Pour mixture on or dip parts to be cleaned. Scrub with soft brush. Repeat until foaming stops. Flush with clean water.
9. Remove heavy corrosion build-up from terminals with terminal/post cleaner and/or wire brush.

INSTALL:

NOTE

The 6TN and 6TL batteries can be mixed or matched. However, maintenance-free batteries cannot be mixed or matched with military batteries. The 6TN and/or the 6TL batteries will perform properly in hot weather as long as electrolyte levels are carefully monitored. If the electrolyte expands and causes the level to rise, some fluid must be removed. If the level becomes too low due to evaporation, distilled water may be used to obtain the proper level. A good grade of drinking water (excluding mineral waters) may be used if distilled water is not available.

Electrolyte (NSNs 6810-00-249-9354 and 6810-00-843-1640) have a specific gravity of 1.280 and should be used in these batteries. Do NOT adjust the electrolyte in wet batteries to a lower specific gravity.

1. Position battery (5) in battery box (6).
2. Connect battery cable clamps (4) to battery posts [connect negative terminal last (Point A)].
3. Tighten cable clamp bolts (3) using 10 mm box wrench.
4. Coat battery post and clamp with GAA grease.
5. Replace battery box cover (2).
6. Secure cover with strap (1).
7. Close battery hatch.

3-90. BATTERY CABLES REPLACEMENT INSTRUCTIONS

TOOLS: 10 mm Box Wrench
11 mm Box Wrench
1/2 inch Box Wrench
9/16 inch Socket
Ratchet
14 mm Box Wrench

PARTS/MATERIALS: Battery Cable
Wire Ties (Item 12, Appendix C)
Insulating Plastic Spray Paint (Item 13, Appendix C)
Grease (Item 1, Appendix C)

REMOVE:



WARNING

- Set master switch to "OFF".
- Disconnect batteries.

1. Open and secure engine hatches (refer to paragraph 3-154).
2. Open and secure battery hatch (refer to paragraph 3-154).
3. Disconnect batteries (refer to paragraph 3-69).

NOTE

Battery cables may be fastened to other cables and harnesses with wire ties. Battery cables have a lettered plastic clip at each end for identification. Remove and save this clip for use with new cable.

4. Note battery cables as listed.

<u>Cable</u>	<u>From</u>	<u>To</u>
L	Battery (-)	Battery (+)
A&H	Battery (+) post	Master switch
E&M	Battery (+) post	Emergency link solenoid
B&C	Master switch	Starter B+ terminal
D	Master switch	Slave receptacle (+) terminal
G	Battery (-) post	Starboard starter R -
J	Battery (-) post	Slave receptacle (-) terminal
K	Slave receptacle (-) terminal	Port starter R-
F	Starter (-)	Starter (-)

5. Locate cable to be replaced.

NOTE

Remove cable at battery first if cable is connected to battery post.

6. Use 10 mm box wrench to loosen terminals at battery post.

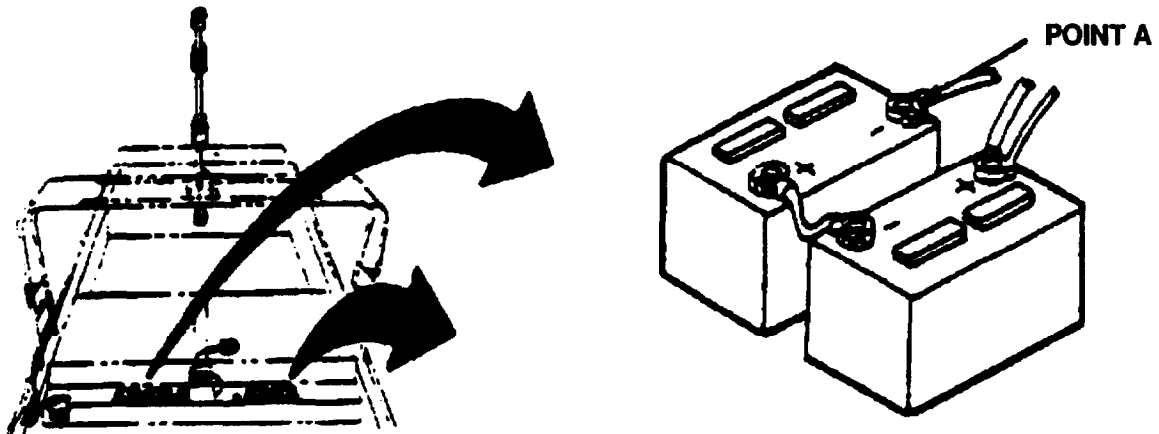

7. Remove terminals from battery post.
8. Use 9/16 inch socket and ratchet to remove nut(s) (1) from terminals of master switch. (Wires are marked by letter, see step 4.)

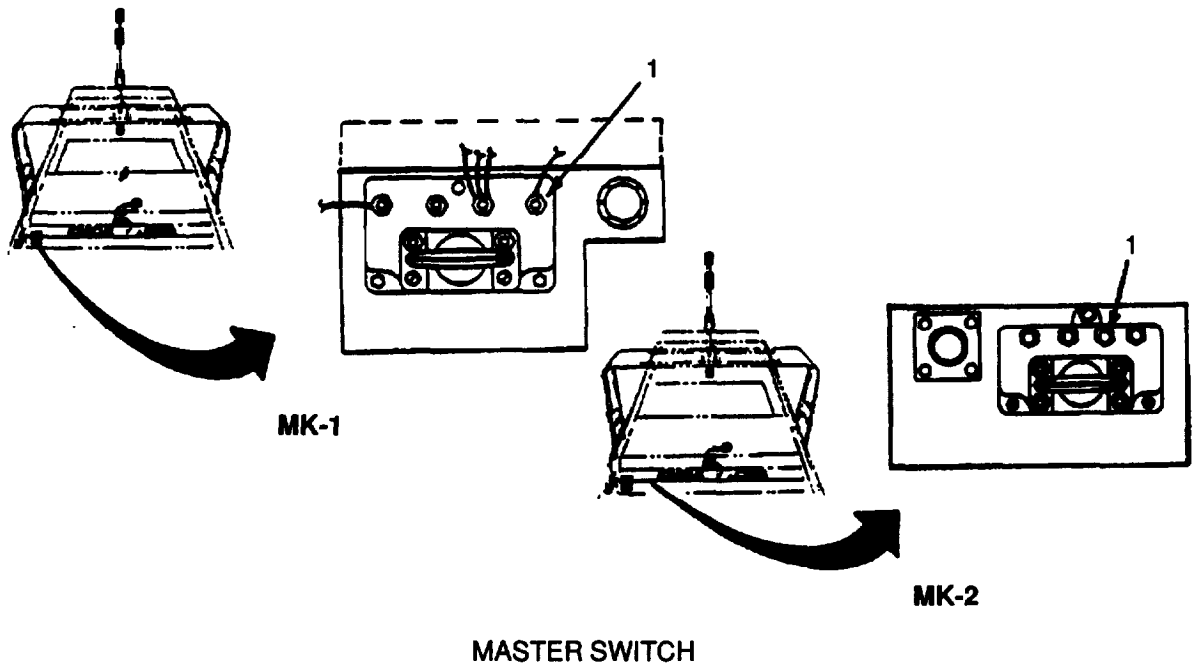

9. Using 1/2 inch box wrench remove nut(s) (2) and washer(s) (3) from starter terminals.

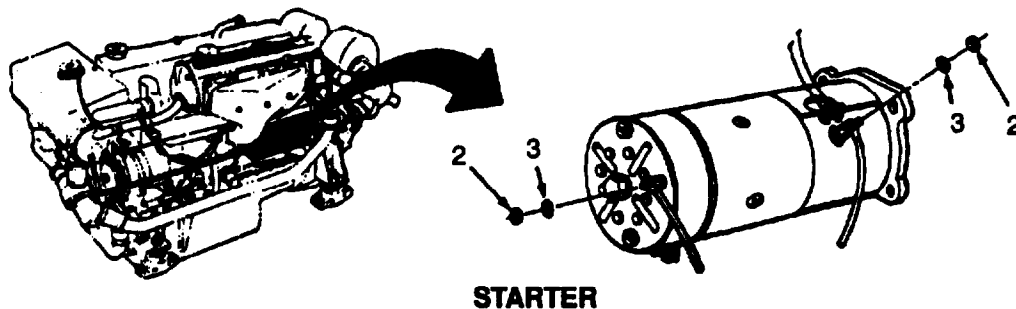

10. Using 11 mm box wrench remove nut(s) (4) and washer(s) (5) from emergency link solenoid terminal.

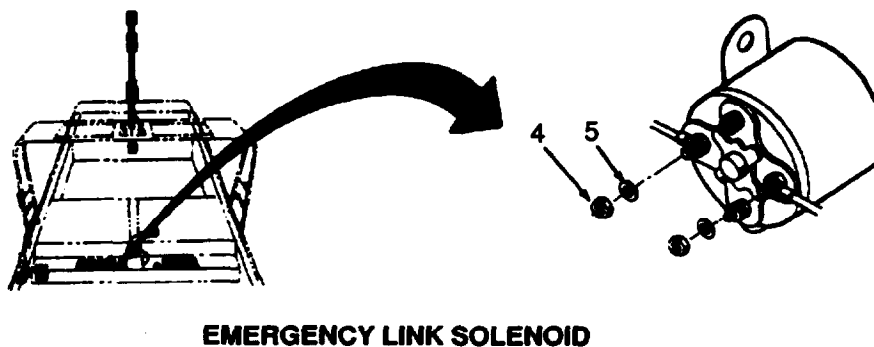

11. Using 14 mm box wrench remove nut(s) (6) from slave receptacle.

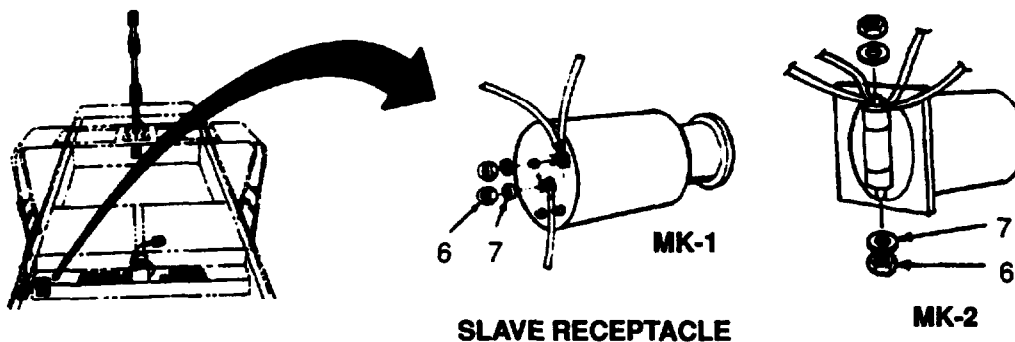

12. Remove washer(s) (7) and cable from terminal.
13. Remove wire ties.

INSTALL:

CAUTION

Connect cable to battery post last. Severe burns or shock may result

1. Install cable end and nut (1) to terminal(s) of master switch.
2. Install cable end, washer(s) (3) and nut(s) (2) to terminal(s) of starter.
3. Install cable end, washer(s) (5) and nut(s) (4) to terminal(s) of emergency link solenoid.
4. Install cable end, washer(s) (7) and nut(s) (6) to terminal(s) of slave receptacle.
5. Replace wire ties.
6. Install cable terminal on battery post and tighten with 10 mm box wrench.
7. Cover battery post and terminals with grease.
8. Spray nuts and terminals with insulating plastic paint.
9. Replace battery box cover and secure with strap.
10. Close all hatches.

3-91. ALTERNATOR AND VOLTAGE REGULATOR TEST

TOOLS: Flat Tip Screwdriver

PARTS/MATERIALS: Jumper Wire, 16 gage or heavier with alligator clips

NOTE

Leave battery connected for this test. Check the integrity of all wiring and connections in the charging system before performing in this test.

1. Open and secure engine hatch (refer to paragraph 3-154).
2. Remove control box cover (refer to paragraph 3-110).

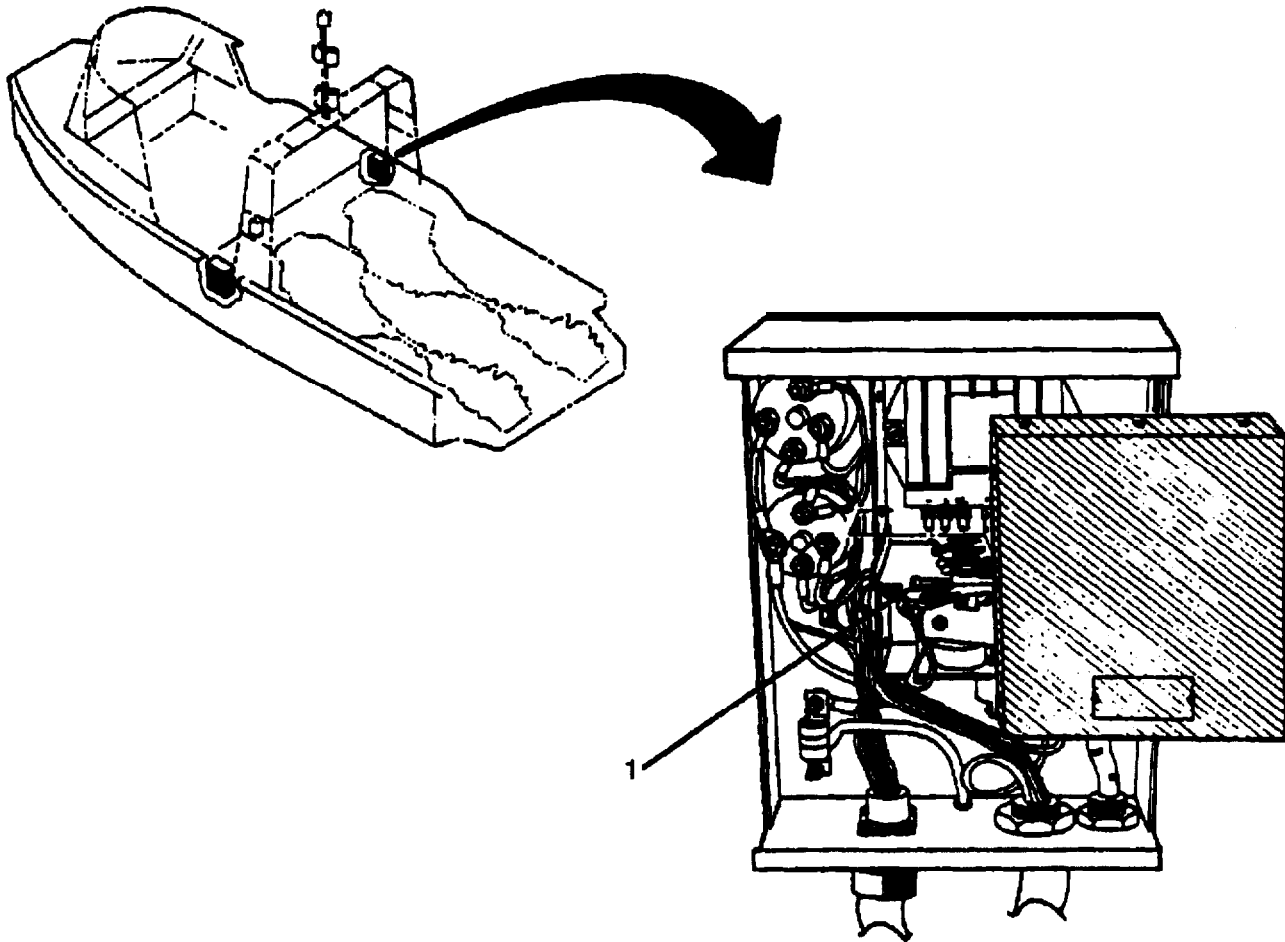

3. Using flat tip screwdriver remove two screws (1) from regulator box cover.

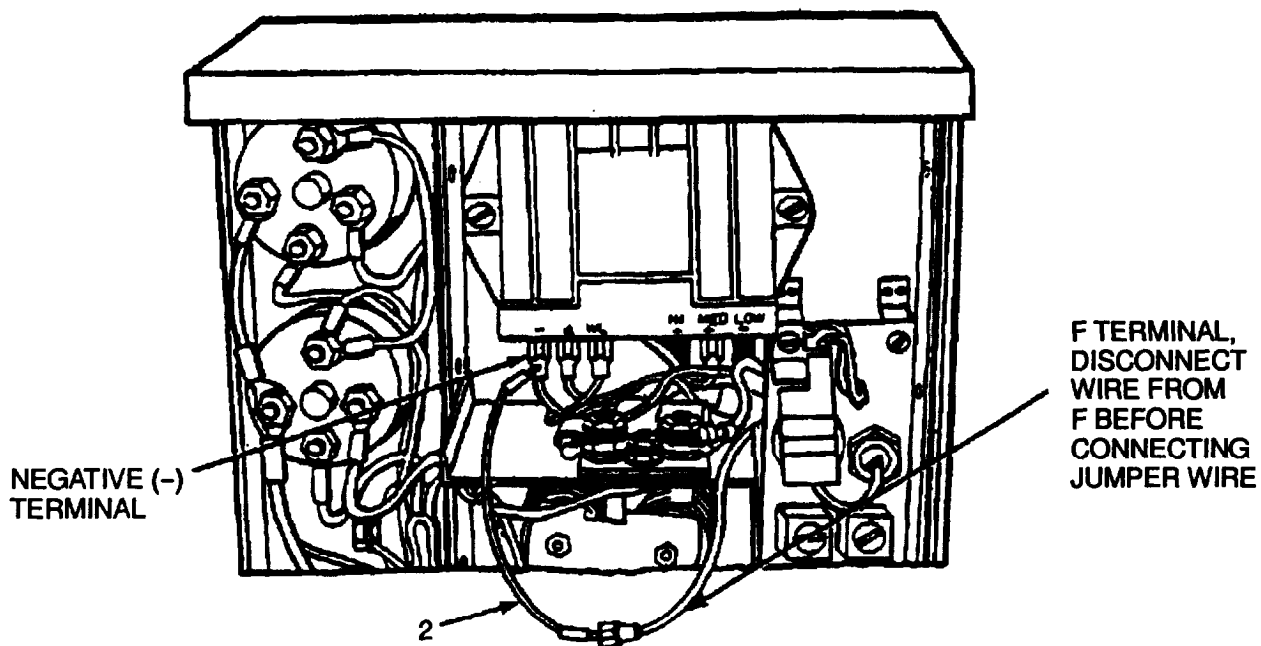

4. Disconnect wire from F terminal on voltage regulator.
5. Use a jumper wire (2) and connect the loose F terminal wire to the negative (-) terminal on voltage regulator.
6. Turn master switch ON.
7. Turn engine circuit switch ON.
 - If warning light comes ON and stays ON, the regulator is bad. Go to step 8.
 - If warning light does not come ON and stay ON, the alternator is bad. Go to step 9.
8. Report defective control box assembly to direct support maintenance.
9. Replace alternator (refer to paragraph 3-92).
10. Turn engine circuit switch OFF.
11. Turn master switch OFF.
12. Disconnect the jumper wire and reconnect the wire to terminal F.
13. Replace voltage regulator cover with two screws (1) using flat tip screwdriver.
14. Replace control box cover (refer to paragraph 3-110).
15. Close engine hatch.

3-92. ALTERNATOR REPLACEMENT INSTRUCTIONS

TOOLS: Flat Tip Screwdriver, 4 inch
Two 11/32 inch Box Wrenches
7/16 inch Box Wrench
5/8 inch Box Wrench
11/16 inch Box Wrench
11/16 inch Open End Wrench
1/4 inch Straight Punch
Hammer
Vise

PARTS/MATERIALS: Alternator

REMOVE:



Set master switch to "OFF".

1. Open and secure engine hatches (refer to paragraph 3-154).

NOTE

Remove buoyancy flotation material on port side of boat to replace port alternator only (refer to paragraph 3-152).

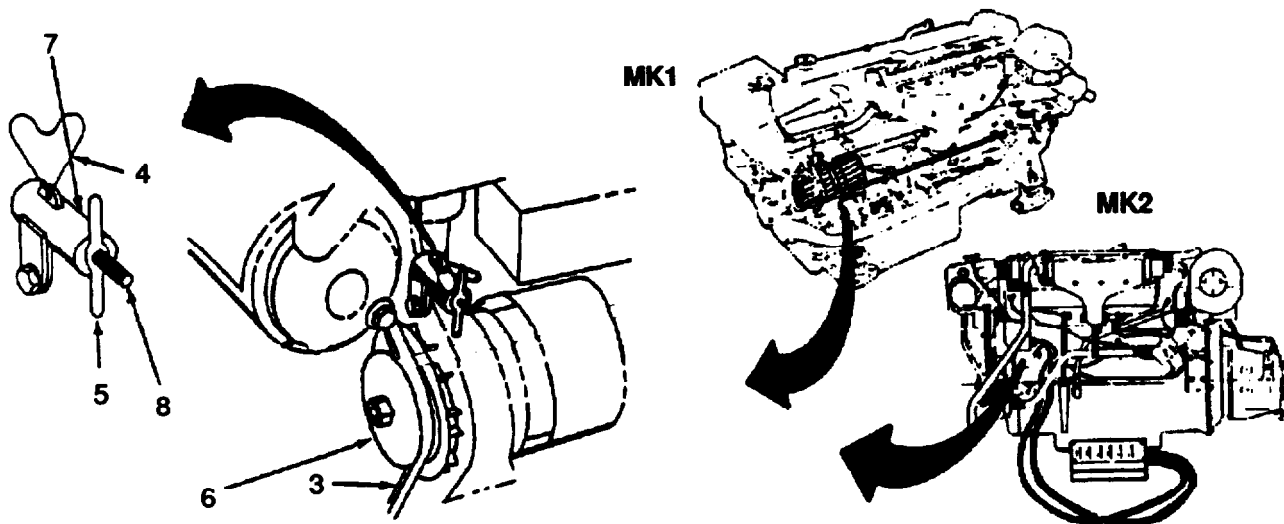

2. Release tension on V-belt (3) by releasing adjuster lock (4) and rotating adjuster handle (5) clockwise.
3. Turn adjuster handle (5) until enough tension is released to remove V-belt (3) from alternator pulley (6).
4. Rotate adjuster handle (5) counterclockwise and remove adjuster mechanism (7) from adjuster rod (8).

NOTE

- • Tilt alternator out to clear intercooler duct.
- Move cover carefully. Broken wires in shielding will require replacement of harness.

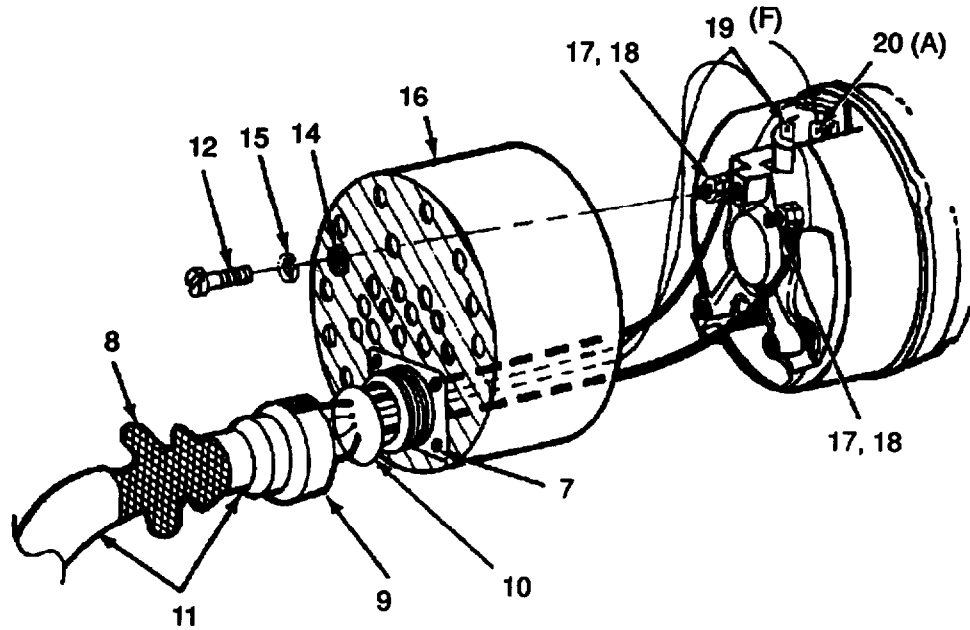

NOTE

Connector nut (9) is hand tightened only.

5. Remove connector nut (9) from electrical plug (10) and slide aft on cable (11).
6. Using screwdriver remove three screws (12), lockwashers (15) and flat washers (14) from alternator cover (16).
7. Slide alternator cover (16) aft over cable (11) to expose wire connections.
8. Note and tag terminal locations of four wires from alternator harness.
9. Using 7/16 inch box wrench remove two nuts (17 and 18) from terminals and disconnect wires.

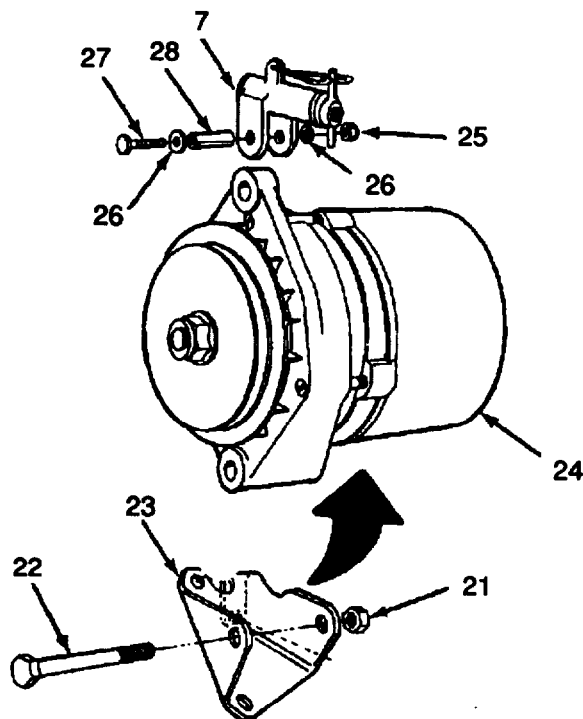

10. Return nuts (17 and 18) to terminals and finger tighten.
11. Pull quick disconnect connectors (19 From Terminal marked F and 20 From Terminal marked A).
12. Using 5/8 inch and 11/16 inch box wrenches remove nut (21) from bolt (22) on alternator mounting bracket (23).
13. Hold alternator (24) with one hand and use other to remove mounting bolt (22) by pulling straight out.
14. Slide cover (16) off cable.
15. Re-attach cover (16) to alternator (24) with three flat washers (14), lockwashers (15) and screws (12).
16. Using two 11/32 inch box wrenches remove nut (25), washers (26) and bolt (27).

CAUTION

Position spring pin (28) over open jaws of vise so weld on adjustment mechanism(7) is not stressed.

17. Using hammer and 1/4 inch straight punch tap out spring pin (28).

INSTALL:

CAUTION

Position hole for spring pin (28) over open jaws of vise so weld on adjustment mechanism (7) is not stressed.

1. Using hammer tap spring pin (28) into adjustment mechanism (7) and new alternator (24).
2. Install washer (26) on bolt (27). Insert bolt (27) thru spring pin (28) and install washer (26) and nut (25).
3. Tighten using two 11/32 inch box wrenches.
4. Fit new alternator (24) to mounting bracket (23) insert bolt (22) and install nut (21).
5. Tighten using 5/8 inch and 11/16 inch box wrenches.
6. Feed four wires thru electrical plug (10) in cover (16).
7. Attach quick disconnect connectors (19) to terminal marked F and (20) to Terminal marked A.
8. Remove nuts (17 and 18) from terminals.
9. Attach wires to terminals as tagged.
10. Return nuts (17 and 18) to terminal and using 7/16 inch box wrench tighten nuts (17 and 18).
11. Aline cover and fasten with three flat washers (14) lockwashers (15) and screws (12).
12. Tighten screws (12) with screwdriver.
13. Attach connector nut (9) to electrical plug (10) and hand tighten.
14. Attach adjuster mechanism (7) to adjuster rod (8).
15. Rotate adjuster handle clockwise until V-belt (3) fits onto alternator pulley (6).
16. Increase tension on V-belt (3) by turning adjuster handle (5) counterclockwise.

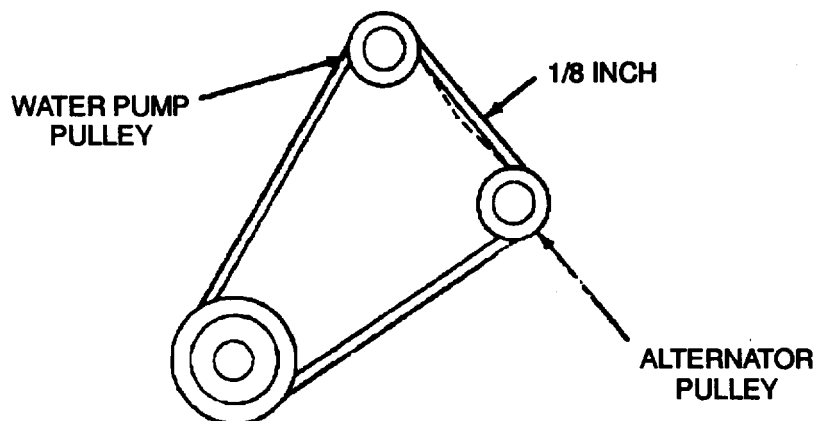

17. Tighten belt until the free movement between the water pump pulley and alternator when pushed is not in excess of 1/8 inch as shown.
18. Replace buoyancy flotation material removed from port side (refer to paragraph 3-152).
19. Close engine hatches.

3-93. ANCHOR LIGHT ASSEMBLY REPLACEMENT INSTRUCTIONS (MK1)

TOOLS: Cross Tip Screwdriver
Small Flat Tip Screwdriver, 4 inch
Flat Tip Screwdriver, 8 inch
8 mm Open End Wrench

PARTS/MATERIALS: Anchor Light Assembly

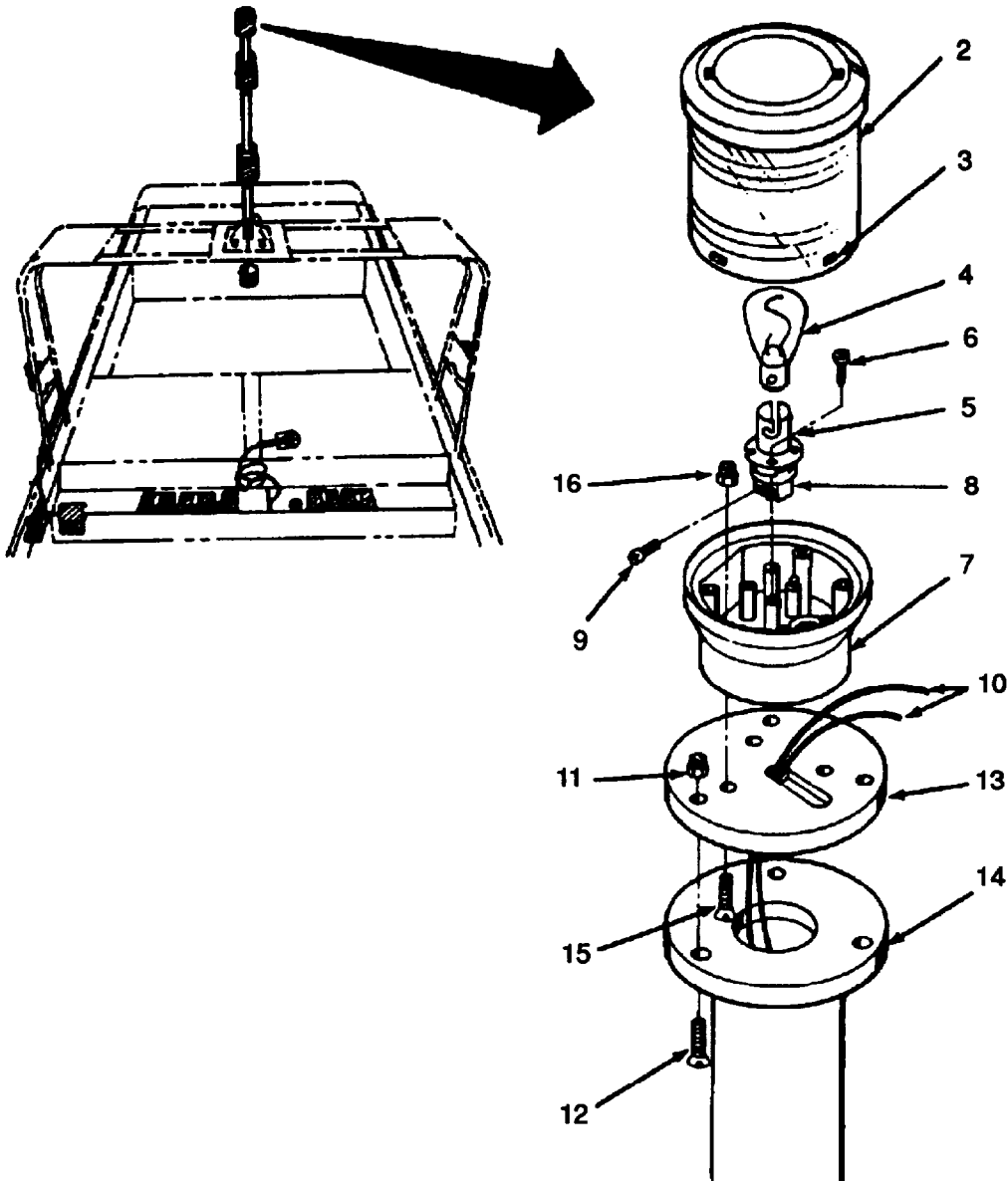

REMOVE:

1. Lower mast (refer to paragraph 3-7). It is not necessary to unplug mast from receptacle (1).
2. Rotate lens (2) counterclockwise until locking lugs (3) are disengaged.
3. Lift lens (2) upward and remove.
4. Remove bulb (4) from lamp socket (5) by pushing in, turning one-quarter turn counterclockwise and pulling out.

5. Using cross tip screwdriver remove two screws (6) securing lamp socket (5) to light assembly base (7).
6. Lift lamp socket (5) free of light assembly base (7) exposing wire terminals (8).
7. Using small flat tip screwdriver loosen terminal screws (9) and pull wires (10) from terminals (8).
8. Using 8 mm open end wrench and flat tip screwdriver remove three self-locking nuts (11) and three bolts (12).
9. Lift light assembly base (7) and mounting plate (13) far enough away from mast top (14) to expose bolt heads (15).
10. Using 8 mm open end wrench and flat tip screwdriver remove three self-locking nuts (16) and three bolts (15).
11. Pull wires (10) out of light assembly base (7) and mounting plate (13). Retain plate (13) for installation of replacement light assembly.

INSTALL:

1. Rotate lens (2) counterclockwise until locking lugs (3) are disengaged.
2. Lift lens (2) free of light assembly base (7).
3. Using cross tip screwdriver remove two screws (6) and lamp socket (5) from light assembly base (7).
4. Feed wires (10) through mounting plate (13) and light assembly base (7) and align bolt holes.
5. Install three self-locking nuts (15) and three bolts (15) securing light assembly base (7) to mounting plate (13).
6. Place mounting plate (13) on top of mast (14) and align bolt holes
7. Install three self-locking nuts (11) and three bolts (12) securing mounting plate (13) to top of mast (14).
8. Insert stripped ends of wires (10) into terminals (8).
9. Using small flat tip screwdriver tighten terminal screws (9) securing wires (10) in terminals.
10. Place lamp socket (5) in light assembly base (7) and install two screws (6) using cross tip screwdriver.
11. Place bulb (4) in lamp socket (5), push down and turn one-quarter turn clockwise to secure in place.
12. Place light lens (2) into light assembly base (7) and rotate clockwise to engage locking lugs (3).
13. Raise mast (refer to paragraph 3-8).

3-94. ANCHOR LIGHT ASSEMBLY REPLACEMENT INSTRUCTIONS (MK2)

TOOLS: Cross Tip Screwdriver
Flat Tip Screwdrivers

PARTS/MATERIALS: Anchor Light Assembly
Light Bulb

REMOVE:

1. Lower mast (refer to paragraph 3-8). It is not necessary to unplug mast from receptacle (1).

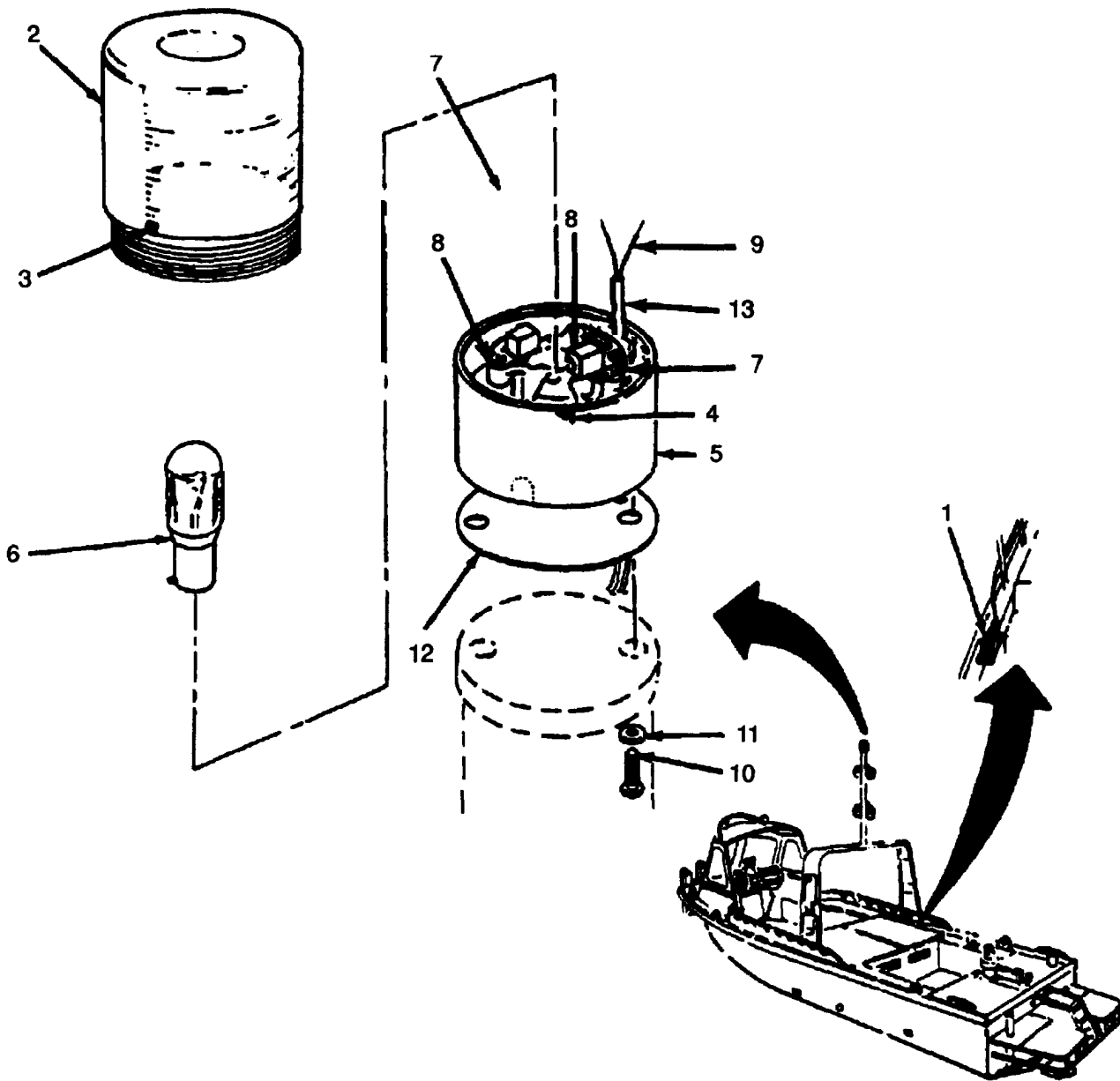

2. Turn lens (2) counterclockwise until lens mark (3) aligns with removal mark (4) on light assembly base (5).
3. Remove lens (2) from light assembly base (5).
4. Remove bulb (6) from lamp socket (7) by pushing in, turning onequarter turn to left and pulling out.
5. Using flat tip screwdriver loosen terminal screws (8) and disconnect wires (9).
6. Remove silicone sleeves (13) from the wires (9).
7. Using flat tip screwdriver remove two screws (10) and washers (11) securing light assembly base (5) and mounting gasket (12) to mast top. Keep screws for installation.
8. Pull light assembly base (5) away from mast top so that wires (9) slip through hole in base.

INSTALL:

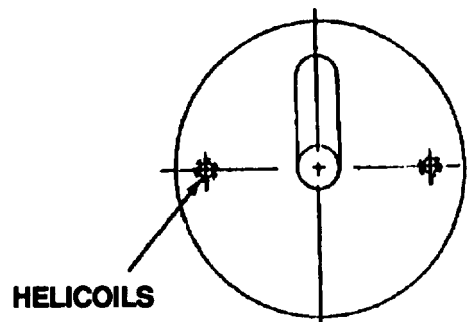

1. Install helicoils in base of new lamp assembly as shown.
2. Slide silicone sleeves (13) provided with new assembly on to the wires (9).
3. Feed wires (9) from the mast through the mounting gasket (12) provided with new assembly and hole in base.
4. Place stripped ends of wires (9) as tagged on terminal screws (8) and secure using flat tip screwdriver.
5. Using flat tip screwdriver install two screws (10) and washers (11) securing light assembly base (5) to mast top.
6. Place bulb (6) in lamp socket (7) push down, and turn onequarter turn to dght to secure.
7. Place lens (2) on light assembly base (5) so that lens mark (3) aligns with removal mark (4).
8. Turn lens (2) clockwise until lens mark (3) aligns with stop position on light assembly base (5).
9. Raise mast (refer to paragraph 3-8).

3-95. TOWING, STEAMING, AND NAVIGATION LIGHT ASSEMBLY REPLACEMENT INSTRUCTIONS (MK1)

TOOLS: Cross Tip Screwdriver
Flat Tip Screwdriver

PARTS/MATERIALS: Light Assembly

REMOVE:

1. Lower mast (refer to paragraph 3-8).

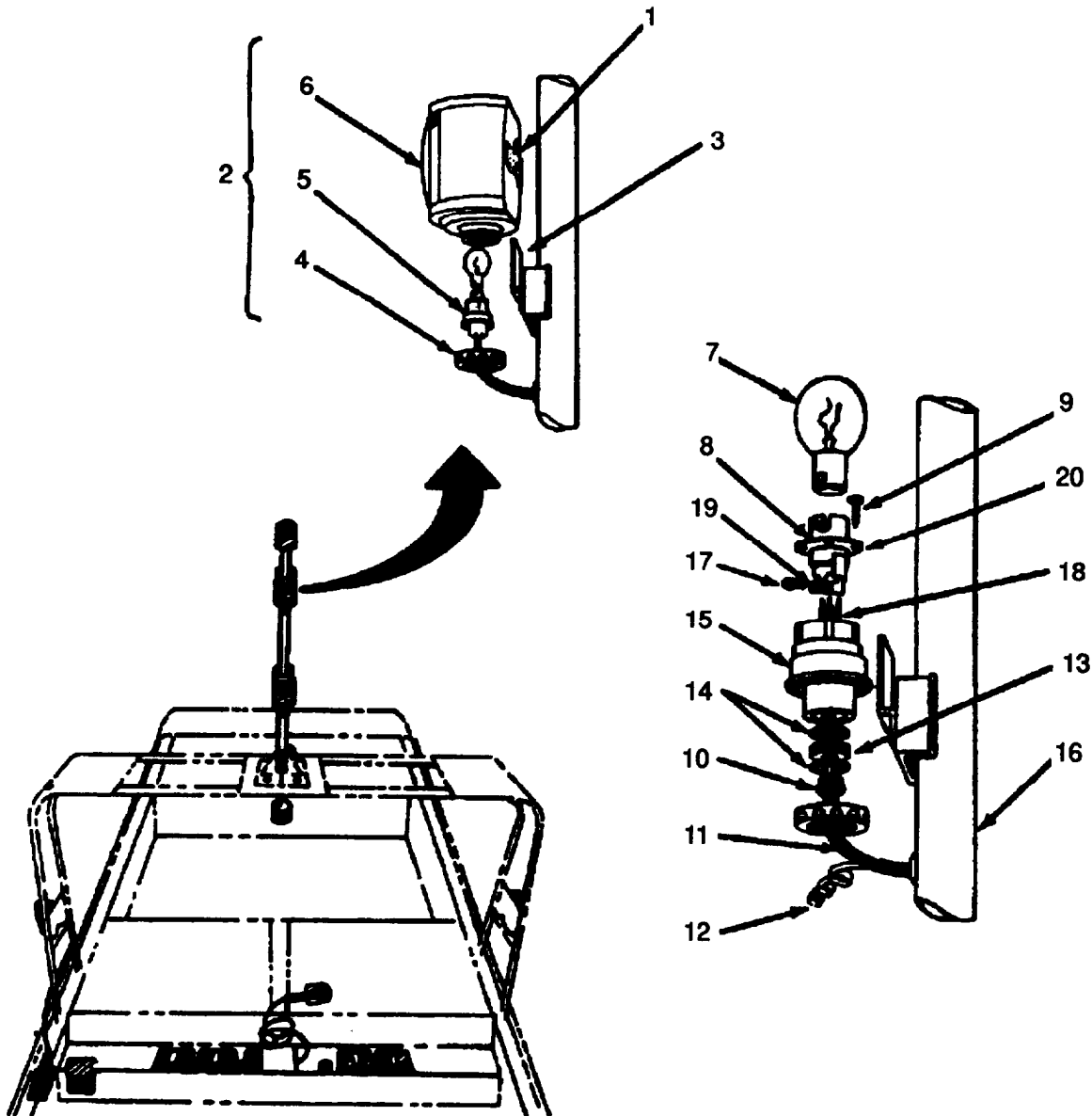

2. Release mounting lock by pushing lever (1) to left.
3. Remove light assembly (2) from mounting bracket (3) on mast.
4. Unscrew collar (4) from bottom of light assembly.
5. Remove lamp socket assembly (5) from lens base (6).
6. Remove bulb (7) from socket (8) by pushing in, turning one-quarter turn counterclockwise and pulling out.
7. Using cross tip screwdriver remove two screws (9) from top of socket (8).
8. Using fingers unscrew locking nut (10) and slide down wire (11) toward mast.
9. Uncoil plastic spiral wrapping (12) from around wire (11) and retain for reinstallation.
10. Slide rubber grommet (13) and two brass washers (14) down wire from socket base (15).
11. Slide socket base (15) down wire toward mast (16).
12. Using flat tip screwdriver loosen two terminal screws (17) holding wires (18).
13. Remove wires (18) from lamp socket terminals (19).

INSTALL:

1. Unscrew collar (4) and remove lamp socket base (15) from lens base (6).
2. Using cross tip screwdriver remove two screws (9) and lamp socket (8) from lamp socket base (15).
3. Remove locking nut (10), rubber grommet (13) and two brass washers (14) from lamp socket base (15) and slide onto wires (11) in correct order.
4. Insert wires (11) into lamp socket base (15).
5. Insert stripped ends of wires (11) into lamp socket terminals (19).
6. Using flat tip screwdriver tighten terminal screws (17) securing wires (11) in terminals.
7. Slide lamp socket base (15) out to lamp socket (8).
8. Aline screw holes (20) in base (15) and top half of socket (6).
9. Insert two screws (9) and tighten with cross tip screwdriver.
10. Slide rubber grommet (13) and two brass washers (14) into lamp socket base (15).
11. Rewind plastic spiral wrapping (12) around wire (11).
12. Slide locking nut (10) to socket base (15) and screw in finger tight.
13. Place bulb (7) in lamp socket (8) push down and turn onequarter turn clockwise to secure.
14. Insert lamp socket assembly (5) into lens base (6).
15. Screw collar (4) onto light base.
16. Install light assembly (2) on mast mounting bracket (3) and lock in place using locking level (1).
17. Erect mast (refer to paragraph 3-8).

3-98. TOWING, STEAMING, AND NAVIGATION LIGHT ASSEMBLY REPLACEMENT INSTRUCTIONS (MK2)

TOOLS: Cross Tip Screwdriver
Flat Tip Screwdrivers

PARTS/MATERIALS: Towing, Steaming, or Navigation Light Assembly
Light Bulb

REMOVE:

1. Lower mast (refer to paragraph 3-8). It is not necessary to unplug mast from receptacle (1).

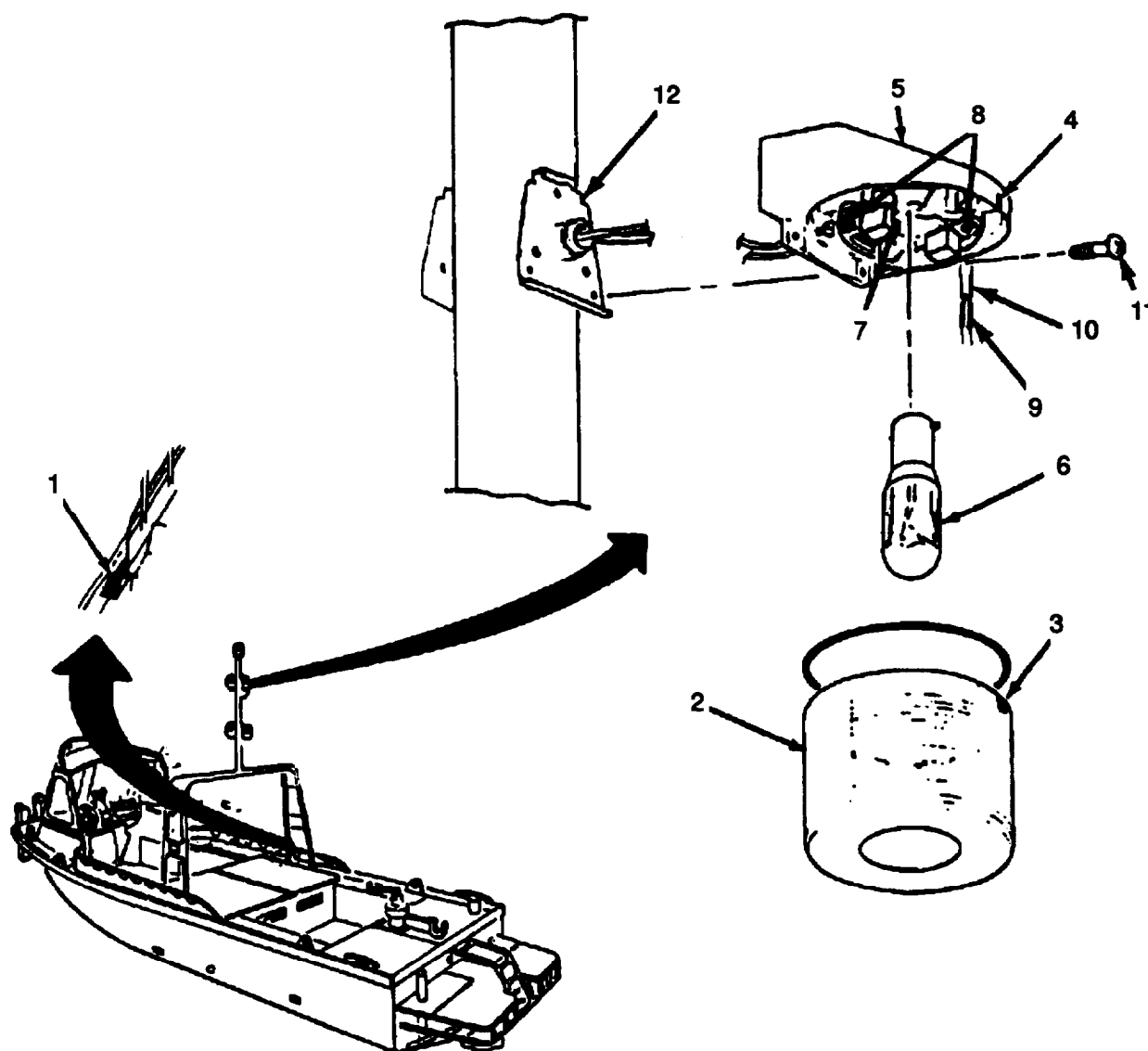

2. Turn lens (2) counterclockwise until lens mark (3) aligns with removal mark (4) on light assembly housing (5).
3. Remove lens (2) from light assembly housing (5).
4. Remove bulb (6) from lamp socket (7) by pushing in, turning onequarter turn to left and pulling out.
5. Using flat tip screwdriver loosen terminal screws (8). Tag and disconnect wires (9).
6. Remove silicone sleeves (10) from wires (9).
7. Using flat tip screwdriver remove the two screws (11) securing light assembly housing (5) to mast mounting bracket (12).
8. Pull light assembly base (5) away from mast so that wires (9) slip through the hole in light assembly housing.

INSTALL:

1. Slide silicone sleeves (10) supplied with new light assembly on to the wires (9) coming from mast mounting bracket (12).
2. Feed wires (9) through the hole in light assembly housing.
3. Using flat tip screwdriver fasten the top of the light assembly with two screws supplied with new light assembly to the mast mounting bracket (12).
4. Using flat tip screwdriver note the terminals wire marking and reconnect stripped wires (9) on to lamp socket terminals (6).
5. Place bulb (6) in lamp socket (7), push down, and turn onequarter turn to right to secure.
6. Place lens (2) on light assembly housing (5) so that lens mark (3) aligns with removal mark (4).
7. Turn lens (2) clockwise until lens mark (3) aligns with stop position on light assembly housing (5).
8. Raise mast (refer to paragraph 3-8).

3-97. SEARCHLIGHT REPLACEMENT INSTRUCTIONS

TOOLS: Two 11 mm Open End Wrenches

PARTS/MATERIALS: Light Assembly

REMOVE:



Set master switch to "OFF"

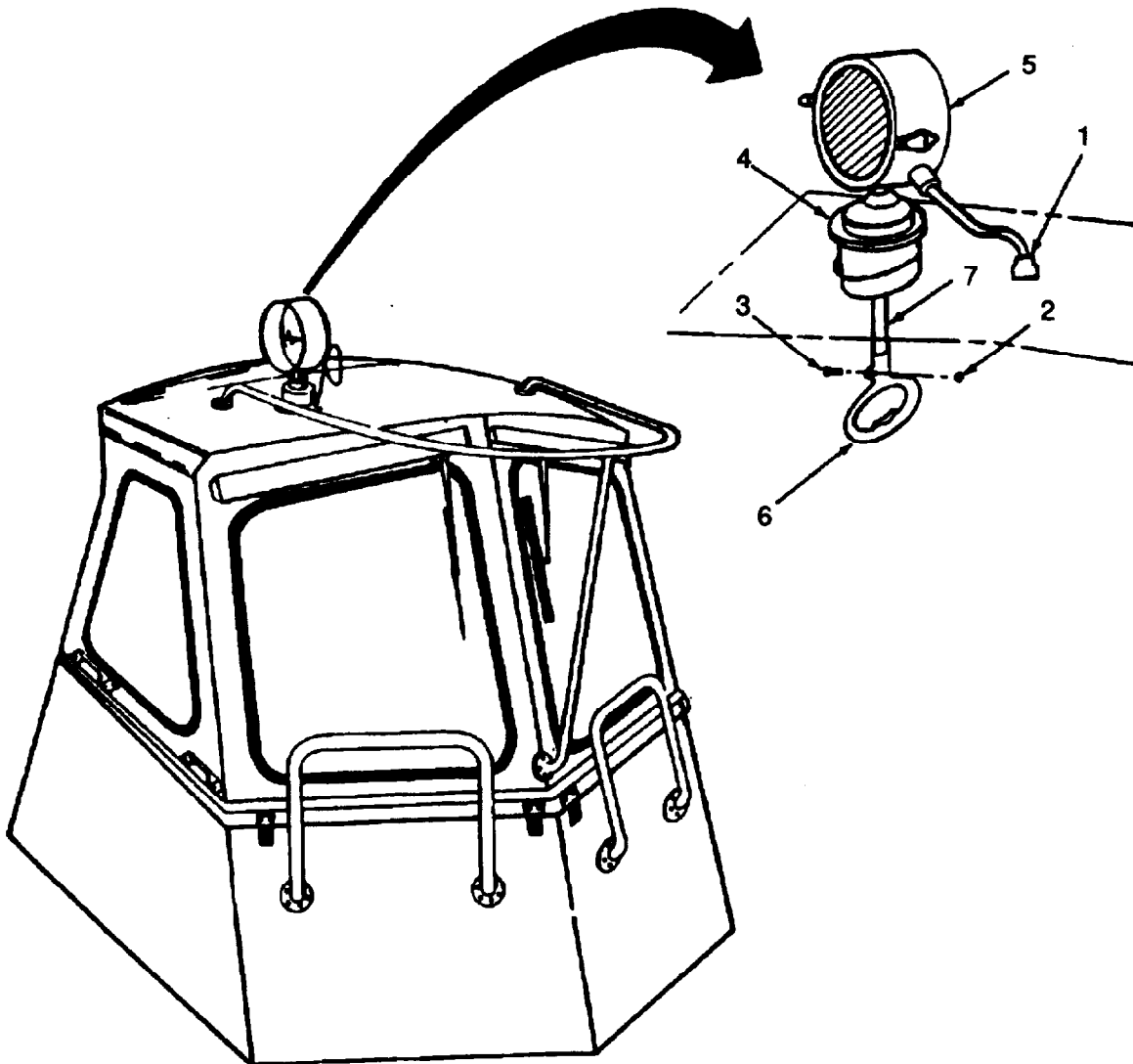

1. Disconnect electric plug (1) (top of cab).
2. Using two wrenches loosen nut (2) and bolt (3) on searchlight handle (6).
3. Remove searchlight handle (6) from shaft (7).
4. Unscrew searchlight body (4) from cab top by turning assembly counterclockwise.
5. Lift light assembly (5) from cab top.

INSTALL:

1. Place new light assembly shaft (7) through cab top.
2. Screw searchlight body (4) to cab top (turn clockwise). Tighten hand tight.
3. Install handle (6) on shaft (7).
4. Install bolt (3) and nut (2) through handle (6).
5. Using two wrenches tighten nut and bolt securing handle (6) to shaft (7).
6. Screw electric plug (1) to receptacle (top of cab).

3-98. INSPECTION LIGHT REPLACEMENT INSTRUCTIONS

TOOLS: None

PARTS/MATERIALS: Light Assembly

REMOVE:



Set master switch to 'OFF'.

1. Open and secure engine hatches (refer to paragraph 3-154).
2. Open and secure battery access cover (refer to paragraph 3-154).

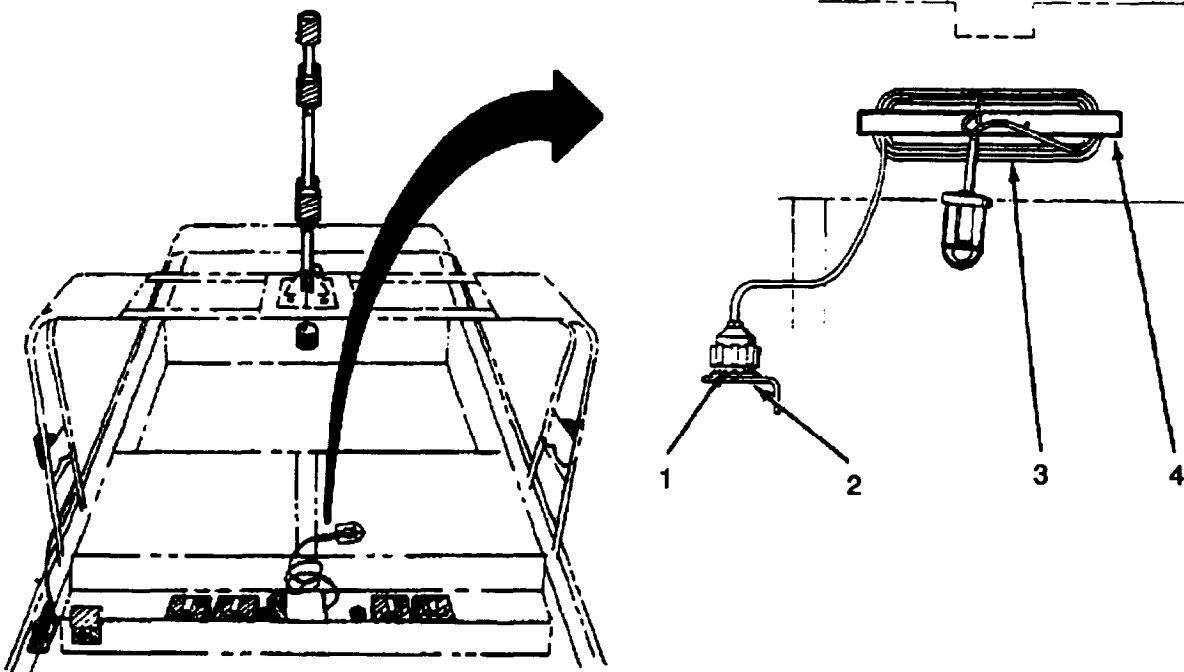

3. Disconnect plug (1) from receptacle (2).
4. Unwrap cable (3) from storage bracket (4).

INSTALL:

1. Connect plug (1) to receptacle (2).
2. Wrap cable (3) around storage bracket (4) to stow new inspection light.
3. Close engine hatches.
4. Close battery access cover.

3-99. MAP LIGHT REPLACEMENT INSTRUCTIONS (MK1 only)

TOOLS: Flat Tip Screwdriver
5/16 inch Box Wrench
Crimping Tool
Wire Cutter

PARTS/MATERIALS: Map Light

REMOVE:

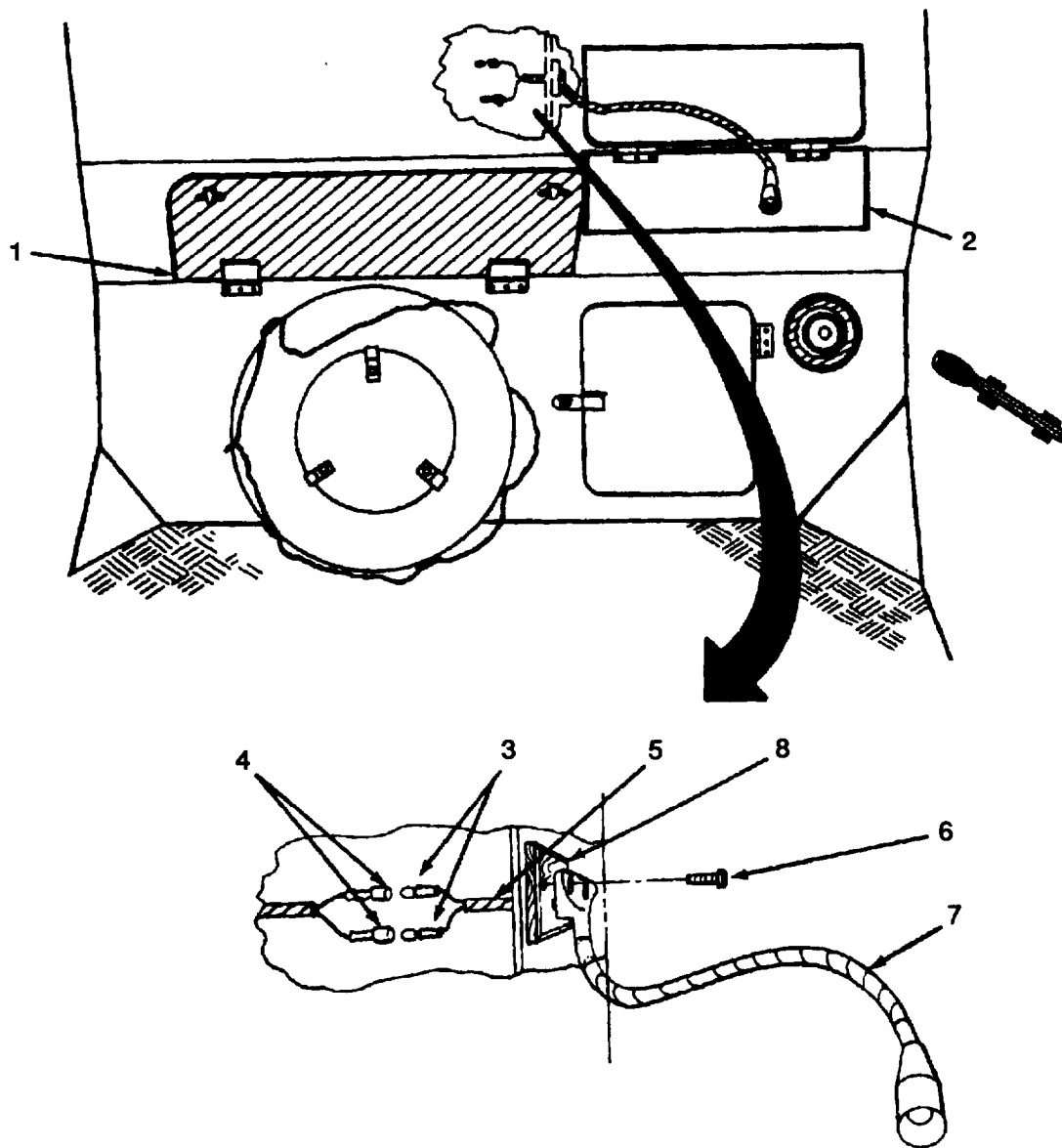

1. Open control console access hatch (1) (refer to paragraph 3-154)
2. Open map locker door (2).
3. Reaching up inside the control console with both hands disconnect Shur terminals (3) from Shur connectors (4).
4. Cut off Shur terminals (3) and discard.
5. Remove plastic spiral covering (5) and save.
6. Reach into map locker and using screwdriver remove two screws (6).
7. Grasp map light (7) and pull out gently (drawing wires thru into the map locker).

REPLACE:

1. Reaching into map locker while grasping map light (7), feed wires thru center hole of mounting Hock (8).
2. Place base of map light (7) against mounting block (8) alining holes in base with those in block.
3. Using screwdriver install two screws (6).
4. Replace plastic spiral covering (5) on wire leads.
5. Using wire stripper, strip 1/4 inch of covering from end of each lead.
6. Place bare ends of wires into new Shur terminals (3) and crimp using crimping tool.
7. Using both hands connect Shur terminals (3) to Shur connectors (4).
8. Close map locker door.
9. Close control console access hatch.

3-100. MASTER SWITCH REPLACEMENT INSTRUCTIONS

TOOLS: 10 mm Socket
9/16 inch Socket
10 mm Box Wrench
6 inch Extension
Ratchet
Flat Tip Screwdriver

PARTS/MATERIALS: Master Switch (Battery Cut-off Switch)
Insulating Plastic Spray Paint (Item 13, Appendix C)

REMOVE:



Disconnect both sets of batteries.

1. Open and secure battery hatch (refer to paragraph 3-154).
2. Disconnect batteries (refer to paragraph 3-89).
3. Note battery cable and terminal position at master switch labeled with letter tags.

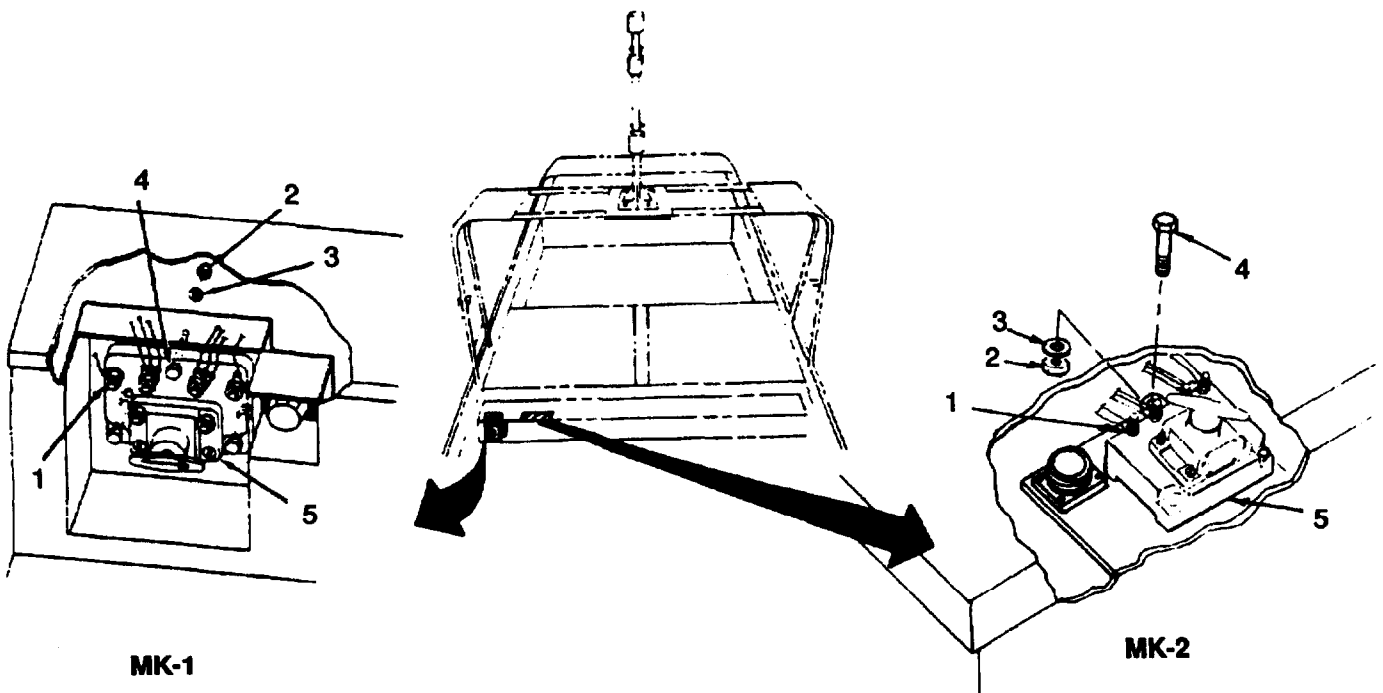

4. Use 9/16 inch socket and ratchet to remove four terminal nuts (1) and remove battery cable from terminals.
5. Use 10 mm box wrench, 10 mm socket, ratchet and flat tip screwdriver to remove three nuts (2), washers (3) and bolts (4) securing master switch (5) to bulkhead bracket.
6. On the MK1 move master switch forward and out of recessed area. On the MK2, lift master switch from bracket.

INSTALL:

1. Place new master switch (5) in recessed area for MK1 or on bracket for MK2.
2. Aline holes in master switch (5) with holes in bulkhead bracket.
3. Install three bolts (4), washers (3) and nuts (2).
4. Tighten bolts (4) and nuts (2) using 10 mm box wrench, 10 mm socket and ratchet and flat tip screwdriver.
5. Reinstall battery cables according to noted position and nuts (1) on terminals of master switch using 9/16 inch socket and ratchet.
6. Spray terminals with insulating plastic paint.
7. Close battery hatch cover (refer to paragraph 3-154).

3-101. OIL AND WATER SENDING UNITS REPLACEMENT INSTRUCTIONS

TOOLS: 7 mm Open End Wrench
17 mm Open End Wrench
19 mm Open End Wrench
12 inch Open End Adjustable Wrench
Slip Joint Pliers

PARTS/MATERIALS: Water Thermocouple
Water High Temperature Switch
Oil Pressure Transmitter
Low Oil Pressure Switch
Funnel
Suitable Container
Coolant (Item 9, Appendix C)
Pipe Tape (Item 2, Appendix C)

CAUTION

Do not leave boat with water system drained, unless a note is attached to start switch.

NOTE

Oil and water sending units are: oil pressure transmitter, low oil pressure switch, water thermocouple, and water high temperature switch. These units are located on port side of engine.

REMOVE:

1. Turn master switch to "OFF.
2. Open and secure engine hatches (refer to paragraph 3-154).

NOTE

- If and engine sending units are to be replaced remove buoyancy flotation material (refer to paragraph 3-152).
- Water must be drained from exhaust manifold to remove either water sending unit. It is not necessary to drain oil to replace the oil sending units.

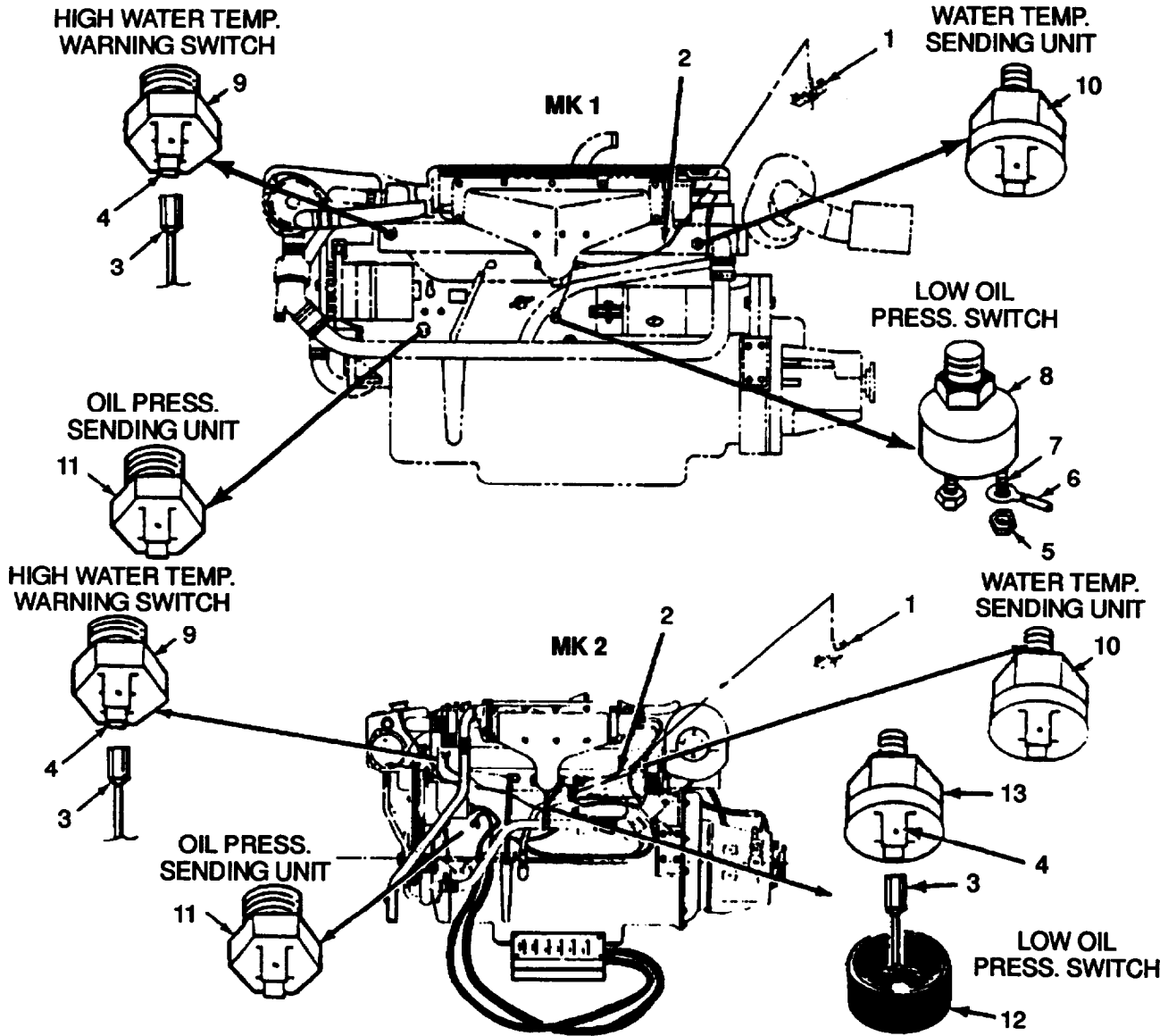

3. Position suitable container and tunnel under drain cock (1) at aft end of exhaust manifold (2).
4. Using pliers loosen drain cock (1) and open by hand.

NOTE

Tag wires before disconnecting to make reconnection easier.

5. Disconnect wiring quick disconnect connector(s) (3) from terminal(s) (4) on sending units and switches.

6. For MK1, using 7 mm box wrench, remove nut(s) (5) and connector(s) (6) from terminal(s) (7) of low oil pressure switch (8). Using 17 mm open end wrench, remove low oil pressure switch (8).
7. For MK2, remove boot (12) from low oil pressure switch (13) and disconnect wiring quick disconnect connector (3) from terminal (4) of low oil pressure switch (13). Using 17 mm open end wrench remove low oil pressure switch (13).
8. Using adjustable wrench remove high water temperature warning switch (9) from exhaust manifold.
9. Using 19 mm open end wrench remove water temperature sending unit (10) from exhaust manifold.
10. Using 17 mm open end wrench remove oil pressure sending unit (11).

INSTALL:

NOTE

For proper seal and to prevent water or oil leak use pipe tape on threads of sending units (10) and (11) and switches (8), (9) and (13). Coat only first four threads. One wrap is enough.

1. Coat first four threads of sending units (10) and (11) and switches; (8), (9), and (13).
2. Install sending units and switches by hand to make sure threads are not damaged.
3. Tighten sending units and switches with same wrench used for removal.
4. Push wiring quick disconnect connector(s) (3) on same terminal(s) (4) as removed from old sending units and switches. (Check tags for correct connection.)
5. For MK1, place connector(s) (6) on terminal(s) (7) of oil pressure switch (8) and tighten nut(s) (5) using 7 mm box wrench.
6. For MK2, push wiring quick disconnect connector(s) (3) on terminal(s) (4) of low oil pressure switch (13) and install boot (12).
7. Fill fresh water system with coolant (if drained).

NOTE

Replace buoyancy flotation material if removed (refer to paragraph 3-152).

8. Close engine hatches.

3-102. FUEL LEVEL SENDING UNIT REPLACEMENT INSTRUCTIONS

TOOLS: 8 mm Box Wrench
19 mm Open End Wrench
Electrical Tool Kit

PARTS/MATERIALS: Fuel Level Float Switch
Snap Wiring Terminals



- Set master switch to "OFF".
- Disconnect batteries.

REMOVE:

1. Open and secure engine hatches (refer to paragraph 3-154).
2. Disconnect batteries (refer to paragraph 3-89).
3. Drain fuel tank (refer to paragraph 3-59).

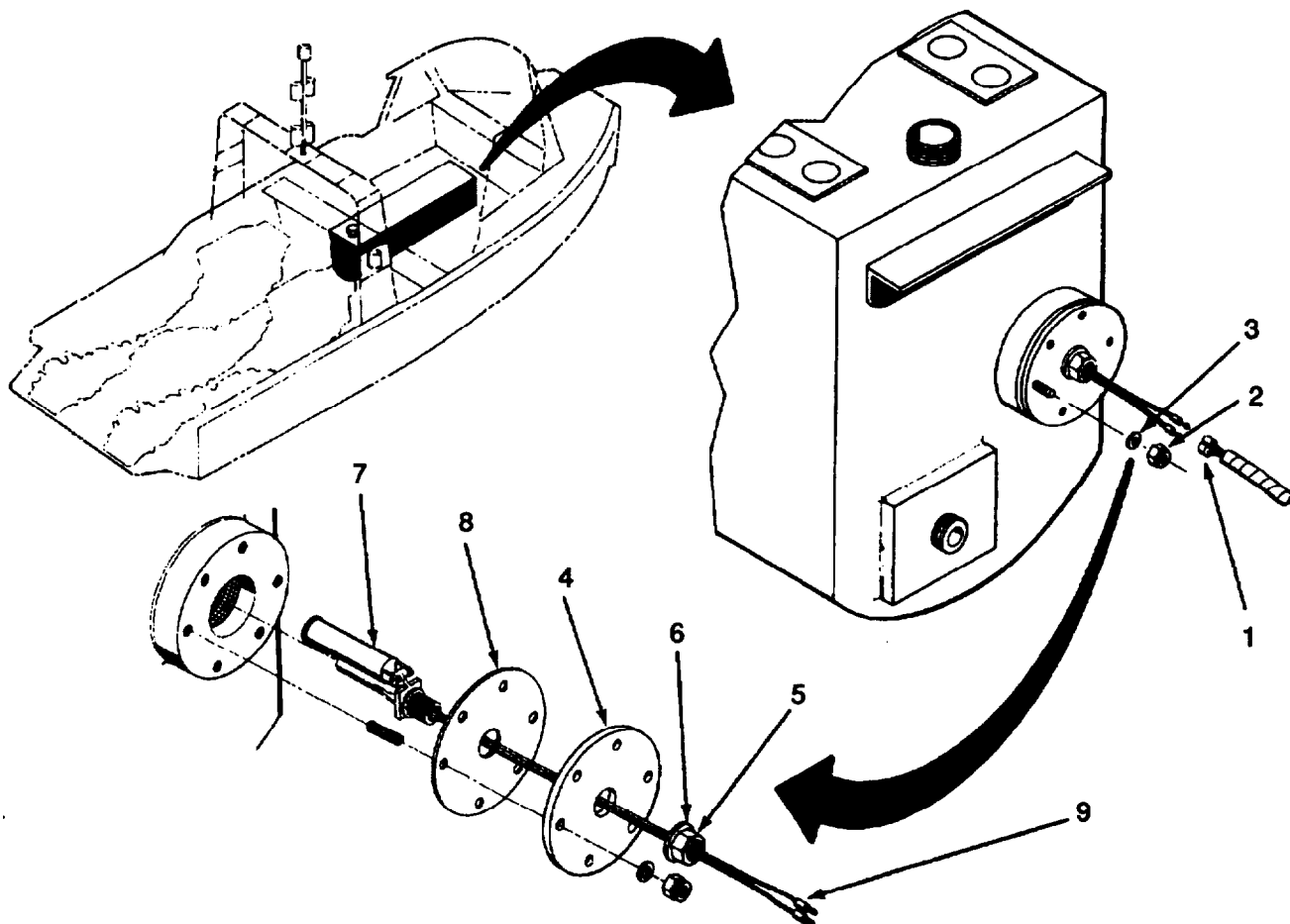

4. Disconnect wire leads (1).
5. Using 8 mm box wrench remove six nuts (2) and washers (3) securing mounting plate (4) and remove from tank
6. Using 19 mm open end wrench remove nylon sender unit lock nut (5) and washer (6).
7. Remove mounting plate (4), seal (8) and fuel level sending unit.

INSTALL:

1. Using 19 mm open end wrench install washer (6) and nylon nut (5) securing new fuel sending unit (7) and seal (8) to mounting plate (4).
2. Using 8 mm box wrench install new fuel level sending unit (7) in fuel tank, taking care that float is oriented for upward flotation.
3. Using wire strippers strip 1/4 inch of insulation from end of lead wires (9).
4. Place stripped wire into barrel of snap wiring terminal.
5. Using crimper crimp terminals to end of wire leads (1).
6. Reconnect wire leads (1).
7. Connect batteries (refer to paragraph 3-88).
8. Close engine hatches (refer to paragraph 3-154).

3-103 TACHOMETER SENDING UNIT ASSEMBLY REPLACEMENT INSTRUCTIONS

TOOLS: 11 mm Box Wrench

7 mm Box Wrencher 9/32 in. Socket & Ratchet

PARTS/MATERIALS: Tachometer Sending Unit Assembly
Tachometer Drive Flange Gasket

REMOVE:

WARNING

- Bet master witch to "OFF".
- No smoking.

1. Open and secure engine hatches (refer to paragraph 3-154).

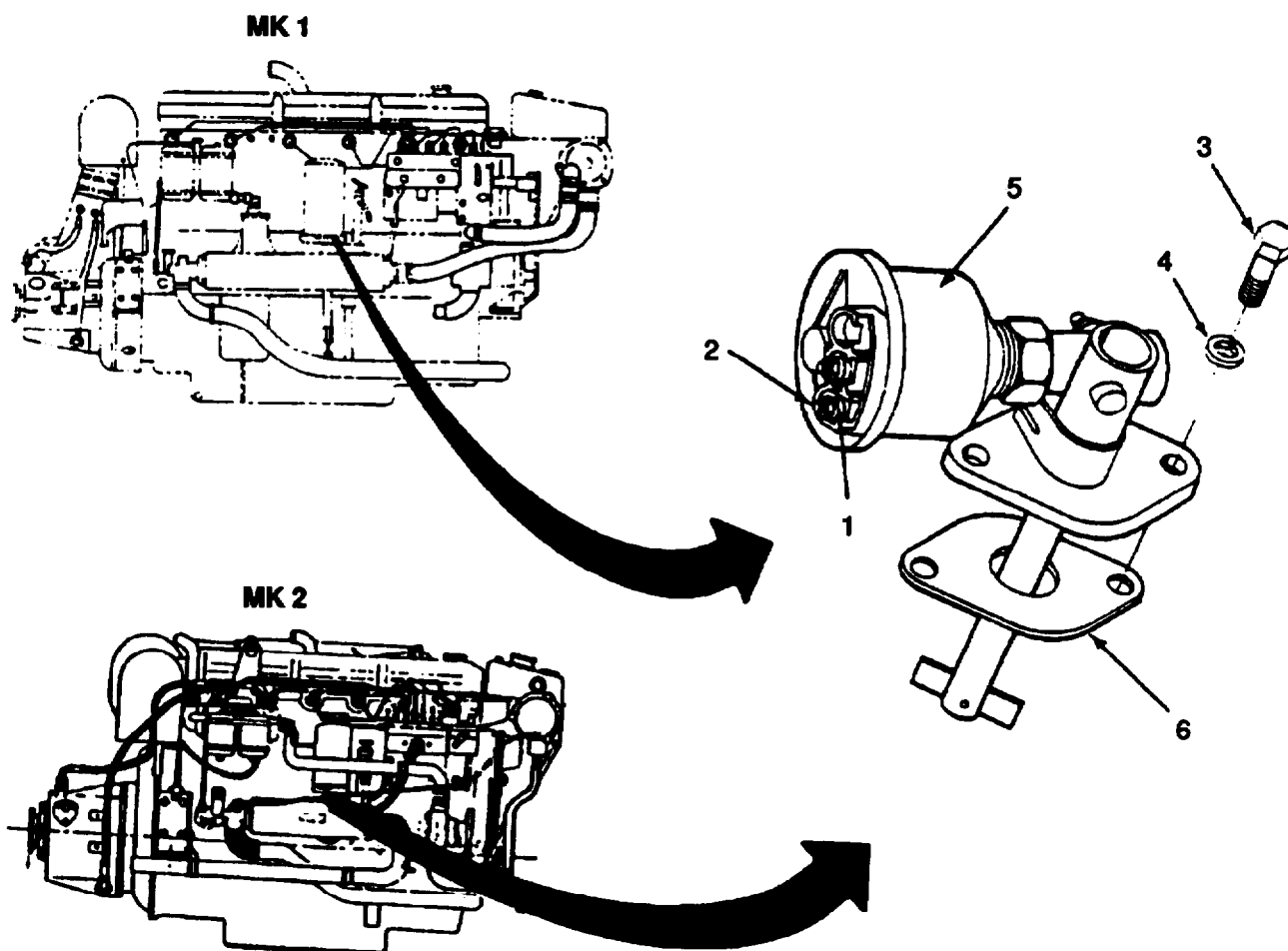

2. Rotate wire and terminal location and using 7 mm box wrench disconnect wires (1) from terminals (2).
3. Using 11 mm box wrench remove two bolts (3) and washers (4) securing tachometer sending unit (5) to engine block.
4. Remove tachometer sending unit (5) from engine by lifting up and out.
5. Remove gasket (6) from engine block. Remove dirt and oil from opening.

NOTE

- Do not allow dirt or debris to enter the opening. If installation of replacement tachometer drive is to be delayed, close the opening with clean rag or paper.
- Insure mounting area on engine block is clean and paper or cloth used to plug hole has not lodged inside.

INSTALL:

1. Install new gasket (6) on engine block and align holes.
2. Install new tachometer sending unit (5) to engine by inserting shaft into hole in engine block. Insure drive flange is aligned.
3. Align holes of tachometer sending unit (5) with holes in gasket (6) and engine block.
4. Using 11 mm box wrench install two mounting bolts (3) and washers (4) and tighten.
5. Connect proper wire (1) to sending unit terminal (2) and tighten nut (2) using 7 mm box wrench.
6. Close engine hatches.

3-104. TACHOMETER SENDING UNIT ASSEMBLY INSPECTION AND REPAIR INSTRUCTIONS

TOOLS: 1 -1/16 inch Open End Wrench

PARTS/MATERIALS: Sender
Drive Tip
Tachometer Drive Flange Gasket

REMOVE:

1. Remove tachometer sending unit assembly (refer to paragraph 3-103).

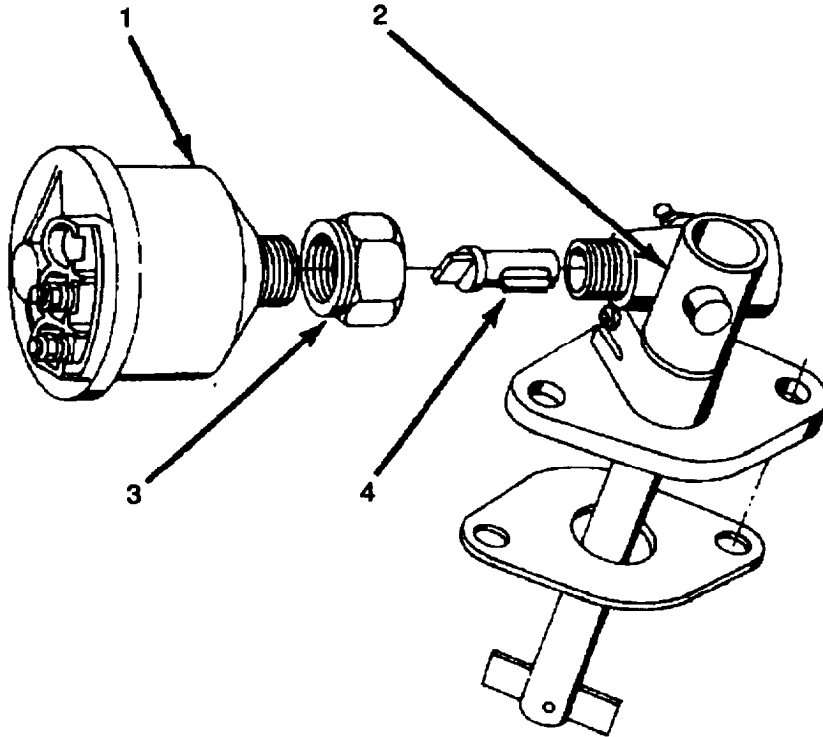

DISASSEMBLE:

1. Using wrench remove tachometer sender (1) from gearbox (2) by turning nut (3) wunterdockwise.
2. Separate assembly and remove drive tip (4).

INSPECT:

1. Inspect tachometer sender (1), gearbox (2) and drive tip (4).
2. Replace damaged part(s).
3. Insert drive tip (4) into gearbox (2). Insure all parts are alined.

ASSEMBLE:

1. Install tachometer sender (1) to gearbox (2) with nut (3). Insure alinement of drive tip (4) between tachometer sender and gearbox.
2. Using wrench tighten nut (3) connecting tachometer sender (1) and gearbox (2).

INSTALL:

1. Install tachometer sending unit assembly (refer to paragraph 3-103).

3-105. ELECTRICAL LEADS, CABLE AND CONNECTORS INSPECTION, REPAIR AND REPLACEMENT INSTRUCTIONS

TOOLS: Electrical Tool Kit

PARTS/MATERIALS: Electrical Wire
Wire Connector (Solderless)
Electrical Tape (Item 11, Appendix C)



- **Set master switch to “OFF”.**
- **Disconnect batteries**

NOTE

- Replacement of electrical leads and connectors is repair of electrical cables. Replace broken electrical lead only, as necessary. Electrical leads and cables that can be replaced are: wires from switch panels, wires to bilge pumps, and instrument cable. Procedure for replacing all electrical leads is the same.
- The exact tool or wire size is determined by wire to be replaced.

REMOVE:

1. Open and secure battery hatch (refer to paragraph 3-154).
2. Disconnect batteries (refer to paragraph 3-89).

NOTE

Open, if necessary:

Engine hatches (refer to paragraph 3-154).
Starboard hydrojet hatch (refer to paragraph 3-154).
Console access panel (refer to paragraph 3-154).
Stowage locker

3. Inspect wire to locate broken area.
4. Cut wire about two inches back on either side of break using wire cutter.

NOTE

This figure illustrates the type of wires that are replaced, as separate wires.

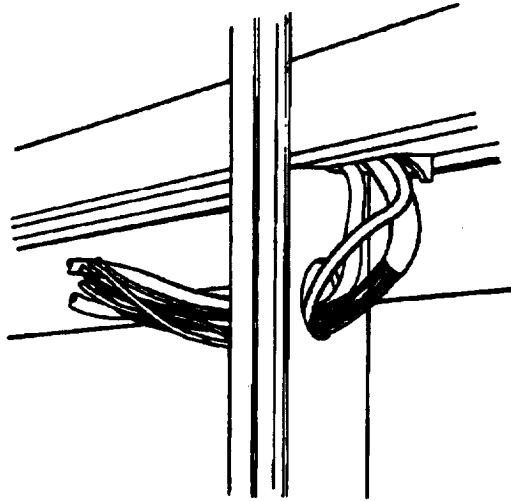

5. Strip about 3/8 inch from end of wire using wire stripper.
6. Measure replacement piece of wire and cut using wire cutter.
7. Strip about 3/8 inch from both ends of replacement wire using wire stripper.
8. Use crimper to crimp wire connector to each end of replacement wire only.
9. Position replacement wire between ends of wire to be repaired and put end of wires into solderless connector.
10. Use crimper to crimp wire connectors securing replacement wire to repaired wire.
11. Tape ends of connectors with electrical tape to insulate the connection.
12. Reconnect batteries (refer to paragraph 3-89).
13. Close battery hatch (refer to paragraph 3-154).

3-106. EMERGENCY LINK SOLENOID TEST AND REPLACEMENT INSTRUCTIONS

TOOLS: 3/16 in. Box Wrench
8 mm Box Wrench
11 mm Box Wrench
10 mm Box Wrench
10 mm Socket
Ratchet
3/16 in. Socket

PARTS/MATERIALS: Solenoid

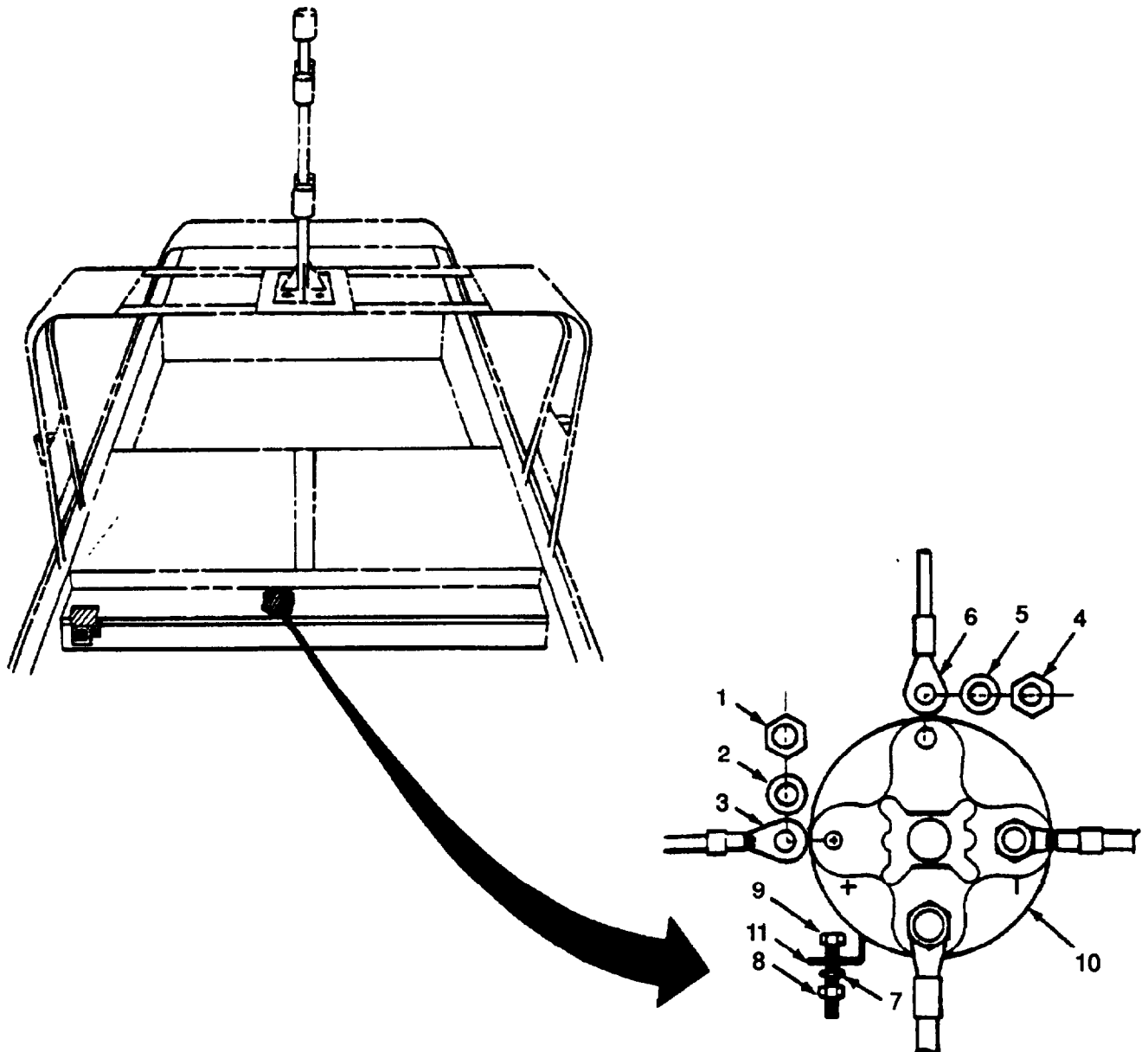

TEST:

1. Test solenoid (refer to paragraph 3-115).

REMOVE:

1. Open and secure battery hatch (refer to paragraph 3-154).
2. Disconnect batteries (refer to paragraph 3-89).
3. Note and tag wire and terminal location on solenoid.
4. Using 8 mm box wrench, remove two nuts (1), washers (2), and wires (3) from solenoid.
5. Using 11 mm box wrench, remove two nuts (4), washers (5), and wires (6) from solenoid.
6. Using 3/16 in. box wrench, 3/16 in. socket, and ratchet, remove two nuts (7), washers (8), and bolts (9) from mount bracket.
7. Remove solenoid (10) and discard.

REPLACE:

1. Aline holes in mounting bracket (11) of solenoid with holes in bulkhead.
2. Using 3/16 in. box wrench, 3/16 in. socket, and ratchet, reinstall two bolts (9), washers (8), and nuts (7).
3. Connect wires (3, 6) to terminals (refer to wiring diagram, page FO-1).
4. Using 8 mm box wrench, reinstall two washers (2) and two nuts (1) on solenoid.

3-107. THERMOSTART UNIT REPLACEMENT INSTRUCTIONS

TOOLS: 7/16 inch Open End Wrench
15/16 inch Open End Wrench

PARTS/MATERIALS: Thermostart Unit

REMOVE:

1. Open and secure engine hatches (refer to paragraph 3-154).

NOTE

Replacement of thermostart unit is the same for both engines. Only a small amount of fuel is in thermostart hose.

2. Note wire location and remove wires (1) from terminals of thermostart unit (2).
3. Use 7/16 inch open end wrench to loosen nut (3) on fuel hose (4) at thermostart unit (2).

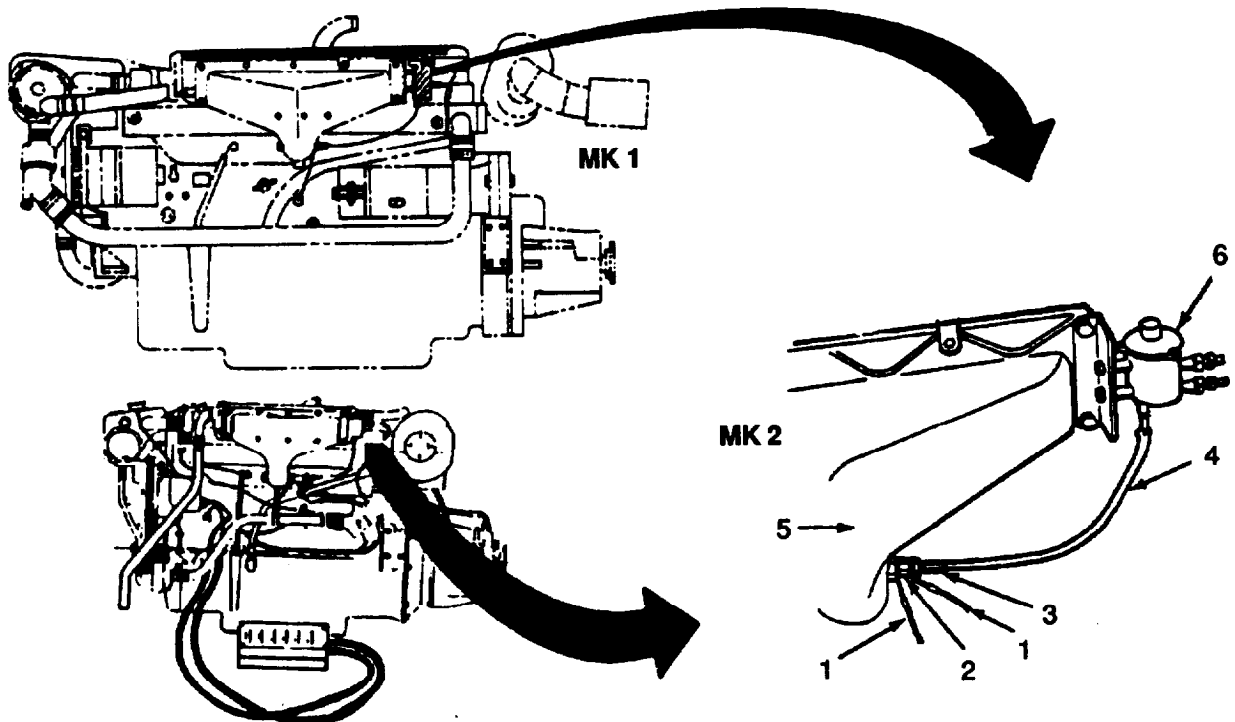

4. Hold rag below end of thermostart reservoir (6), hose (4) and disconnect hose (4) from thermostart unit (2).
5. Use 15/16 inch open end wrench to remove thermostart unit (2) from manifold duct (5).

REPLACE:

1. Install thermostart unit (2) in manifold duct (5) using 15/16 inch open end wrench.

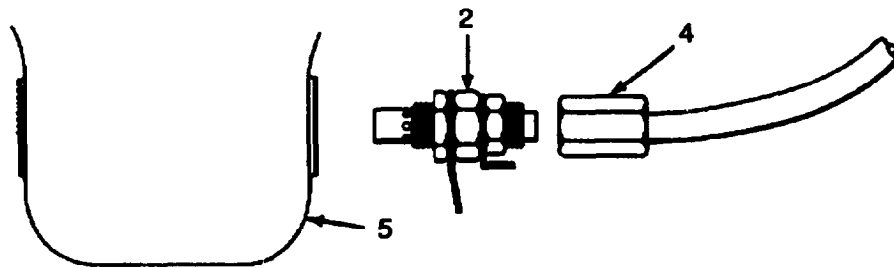
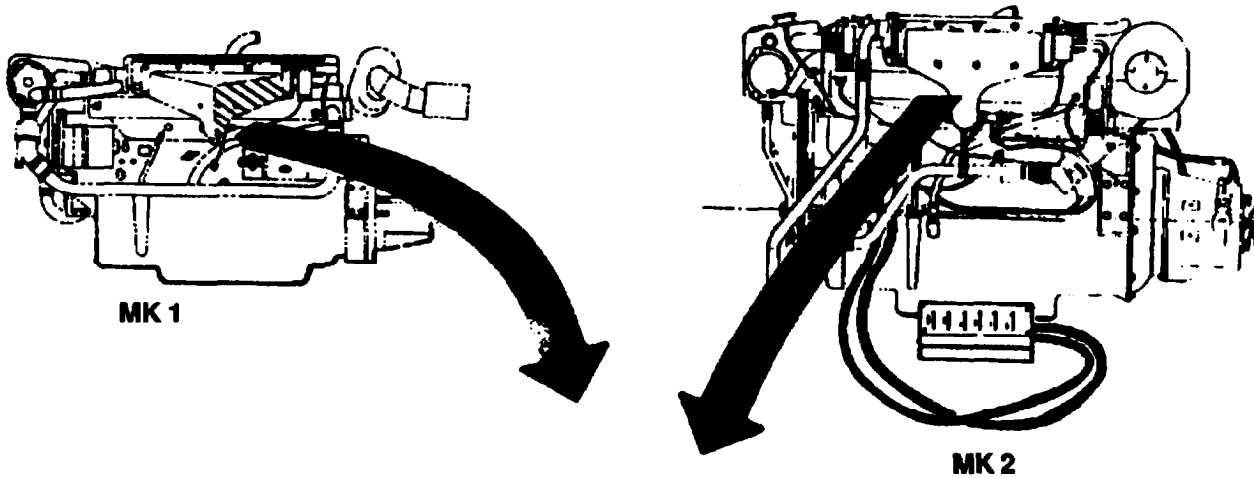

2. Using 7/16 inch open end wrench connect fuel hose (4) to thermstart unit (2) and tighten.
3. Push connectors on terminals.
4. Close engine hatches.

3-108. BLOCKING DIODE TEST

TOOLS: Multimeter
11 mm Socket
Ratchet

1. Tag wires to blocking diode.
2. Using 11 mm socket with ratchet remove nuts (1), washers (2) and wires from terminals of blocking diode (4).

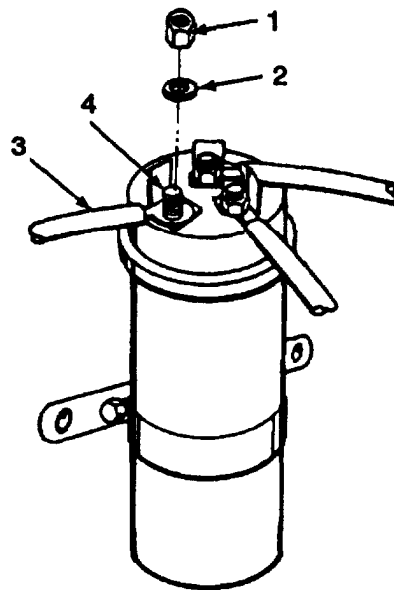

3. Set multimeter to OHMS x 1.

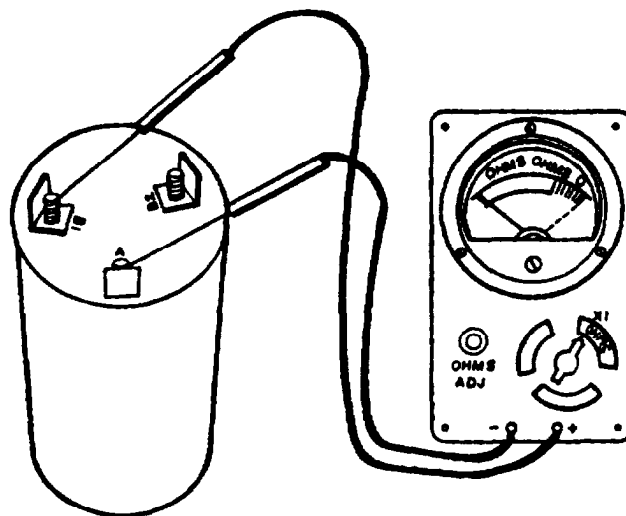

4. Check resistance between diode terminals by doing the five tests listed in the table below.

NOTE

- (-) in table is multimeter negative lead
 (+) in table is multimeter positive lead

Test No.	Diode Terminals			Multimeter Reading Should Be	
	A	B1	B2		
	1	(-)	(+)		
2	(-)		(+)	18-20 OHMS	
3	(+)	(-)		Infinity	
4	(+)		(-)	Infinity	
5		(+)	(-)	Infinity	
6		(-)	(+)	Infinity	

NOTE

Example shown is Test No. 1.

5. Look at multimeter while doing each test.
- If all test readings match the readings listed, the blocking diode is good. Reconnect wires and go to step 6.
 - If any test reading is different from reading listed under "Multimeter Reading Should Be", the blocking diode is bad. Go to step 7.
6. Trouble is not in blocking diode. Go back to troubleshooting procedures for next instruction.
7. Replace blocking diode (refer to paragraph 3-109).

3-109. BLOCKING DIODE REPLACEMENT INSTRUCTIONS

TOOLS: 1/2 inch Socket with 2 inch extension
Ratchet with 3/8 inch drive
9/32 inch Open End Wrench
1/2 inch Open End Wrench
11 mm Socket
Ratchet

PARTS/MATERIALS: Diode
NI Spray Electrical Sealer



Disconnect batteries. Both sets of batteries must be disconnected during parts replacement. Severe burns or shock may result.

NOTE

Area between control box and blocking diode is very close. Only tool combination to remove diode is 3/8 inch drive ratchet and socket. Any other tool requires removal of control box.

REMOVE:

1. Open and secure battery hatch (refer to paragraph 3-154).
2. Disconnect batteries (refer to paragraph 3-89).

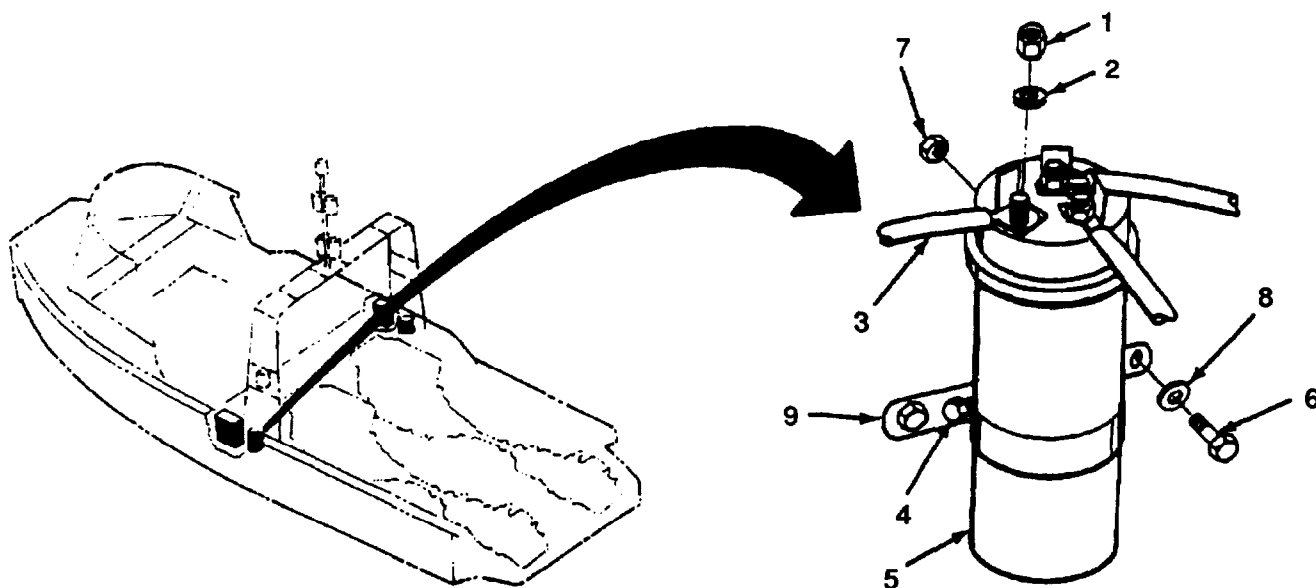

3. Using 11 mm socket and ratchet remove nuts (1), washers (2) and wires (3) from three terminals.
4. Using 1/2 inch socket with 2 inch extension, ratchet, 3/8 inch drive and 1/2 inch wrench remove bolts (6), nuts (7) and washers (8) securing blocking diode to bracket.
5. Using 9/32 inch wrench loosen bracket clamp nut (4) behind diode until diode can be moved.
6. Move diode (5) up and out of bracket (9).

REPLACE:

1. Place new diode (5) in bracket.
2. Position diode (5) with terminals at location as noted.

CAUTION

Do not overtighten clamp. Overtightening can cause failure of diode.

3. Using 9/32 inch wrench, tighten clamp nut (4) until diode (5) cannot be turned by hand.
4. Using 1/2 inch socket with 2 inch extension, ratchet, 3/8 inch drive, and 1/2 inch wrench replace washers (8), bolts (6) and nuts (7) securing blocking diode to bracket.
5. Replace wire (3), washers (2) and nuts (1) and tighten using 11 mm socket and ratchet.
6. Spray terminals, connectors and nuts with NI Spray Electrical Sealer.
7. Connect batteries (refer to paragraph 3-89).
8. Close battery hatch.

3-110. CONTROL BOX COVER REMOVAL/INSTALLATION INSTRUCTIONS

TOOLS: Flat Tip Screwdriver

REMOVE:

1. Open and secure battery hatch (refer to paragraph 3-154).
2. Disconnect all batteries (refer to paragraph 3-89).
3. Open and secure engine hatch (refer to paragraph 3-54).

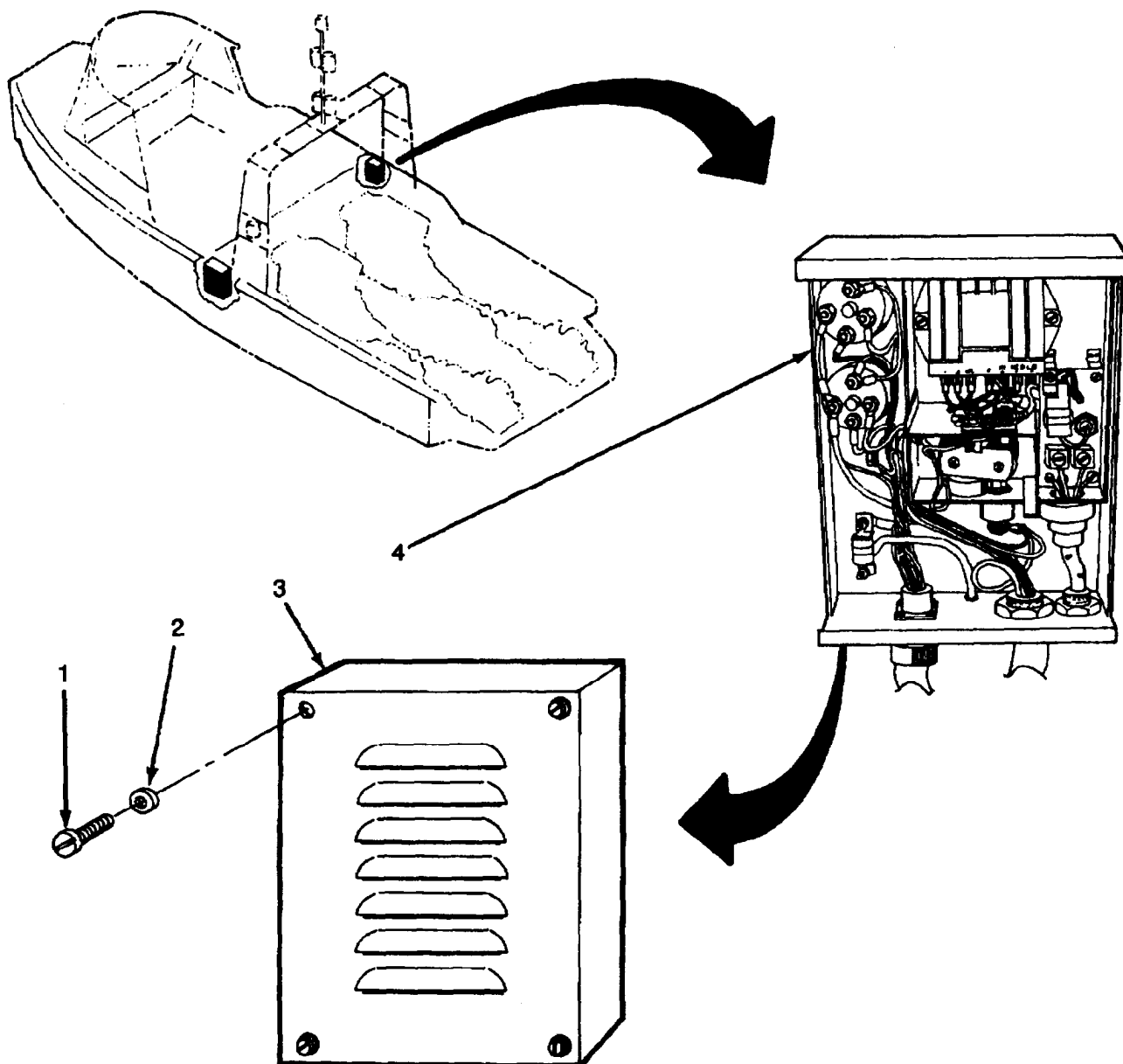

4. Remove four screws (1) and washers (2) securing control box cover (3).
5. Remove control box cover (3).

INSTALL:

1. Place control box cover (3) on control box (4).
2. Install washers (2) and screws (1) in control box cover (3).
3. Close engine hatch (refer to paragraph 3-154).
4. Reconnect batteries (refer to paragraph 3-89).
5. Close battery hatch (refer to paragraph 3-154).

3-111. CONTROL BOX TEST INSTRUCTIONS

TOOLS: Multimeter
Flat Tip Screwdriver

PARTS/MATERIALS: Jumper wire, 16 gauge or heavier with alligator clips.

1. Open and secure battery box hatch (refer to paragraph 3-154).
2. Remove control box cover (refer to paragraph 3-110).

ALTERNATOR AND VOLTAGE REGULATOR TEST:

NOTE

Leave battery connected for this test.

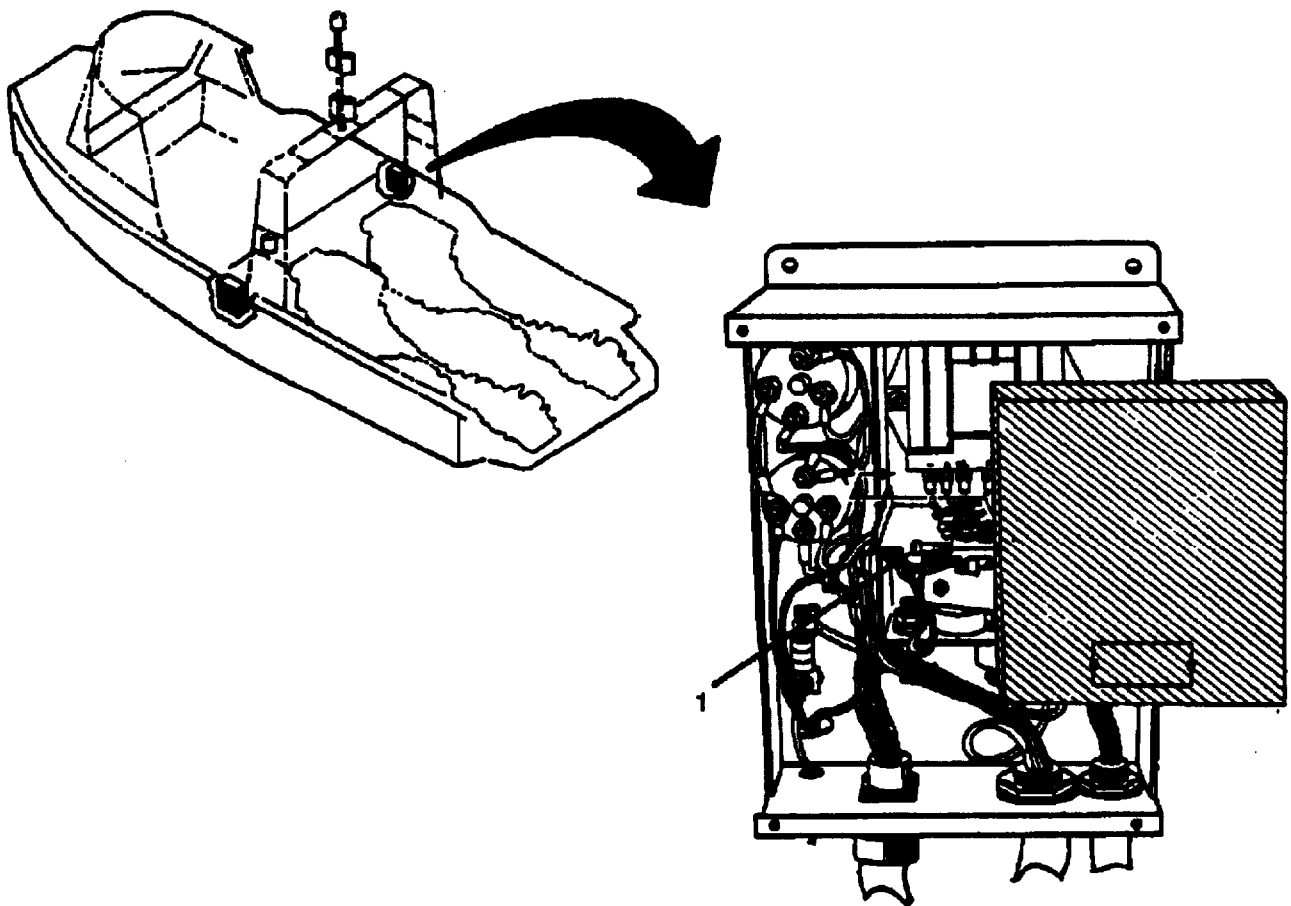

- Using flat tip screwdriver remove two screws (1) from regulator box cover.

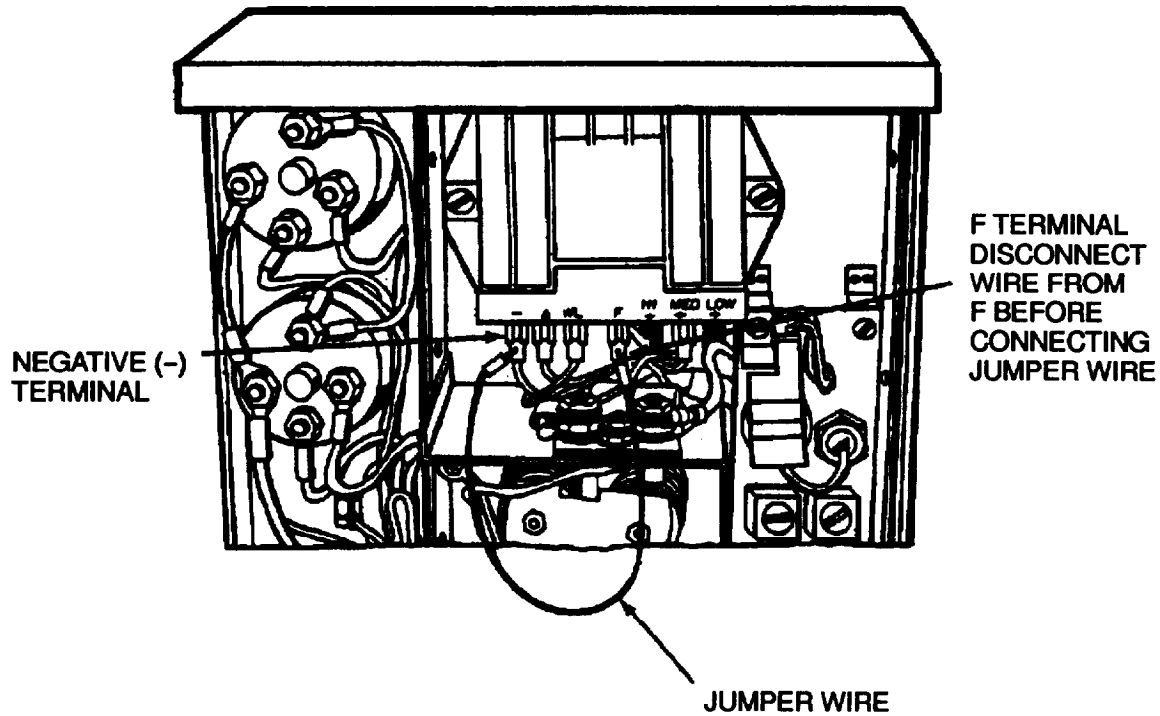

- Disconnect wire from F terminal on voltage regulator.
- Use a jumper wire and connect the disconnected wire to the negative (-) terminal on voltage regulator.
- Turn master switch ON.
- Turn engine circuit switch ON.
 - If warning light comes ON and stays ON, the regulator is bad. Go to step 8.
 - If warning light does not come ON and stay ON, the alternator is bad. Go to step 9.
- Report defective control box to direct support maintenance.
- Replace alternator (refer to paragraph 3-92).
- Disconnect the jumper wire and reconnect the wire to terminal F.

3-112. ENGINE HOUR METER TEST INSTRUCTIONS

TOOLS: Voltmeter

REMOVE:

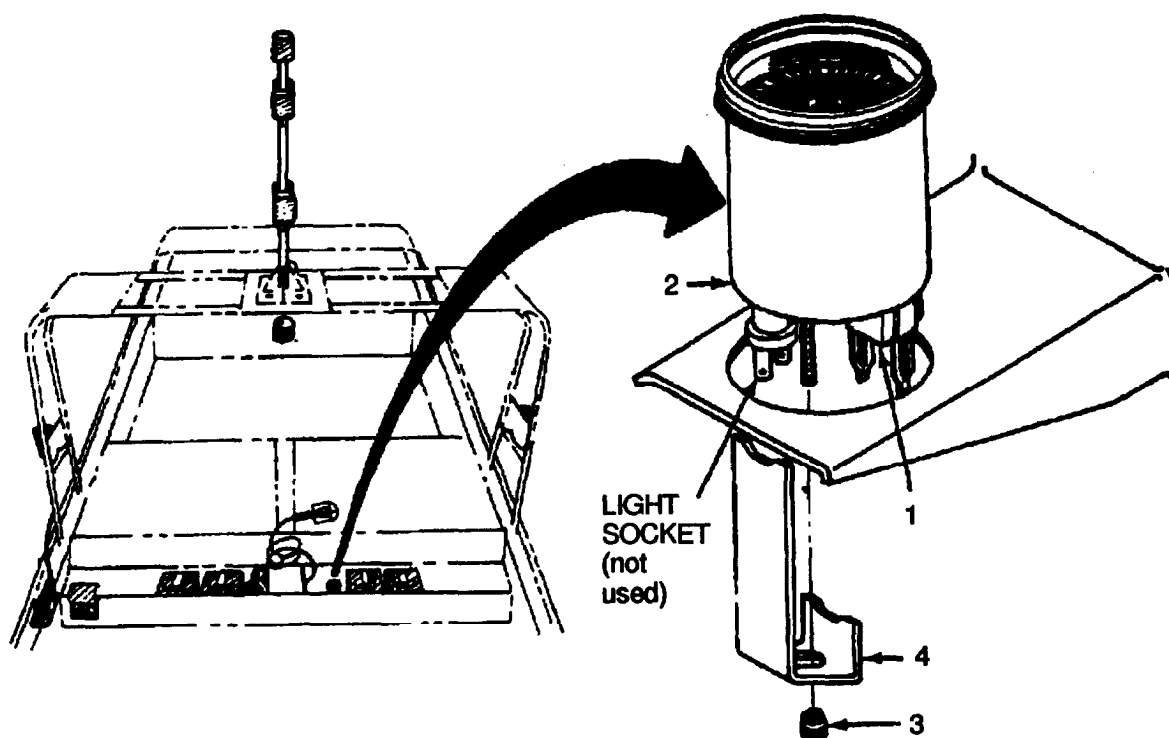

1. Open and secure battery hatch (refer to paragraph 3-154).
2. Disconnect batteries (refer to paragraph 3-89).
3. Disconnect quick-disconnect connectors (1) from base of hour meter (2).
4. Unscrew knurled nut (3) securing brace (4) to hour meter.
5. Remove hour meter.
6. Touch voltmeter probes to hour meter terminals.
7. A positive voltmeter reading indicates that the hour meter is defective.
8. Replace engine hour meter (refer to paragraph 3-113).

3-113. ENGINE HOUR METER REPLACEMENT INSTRUCTIONS

REMOVE:

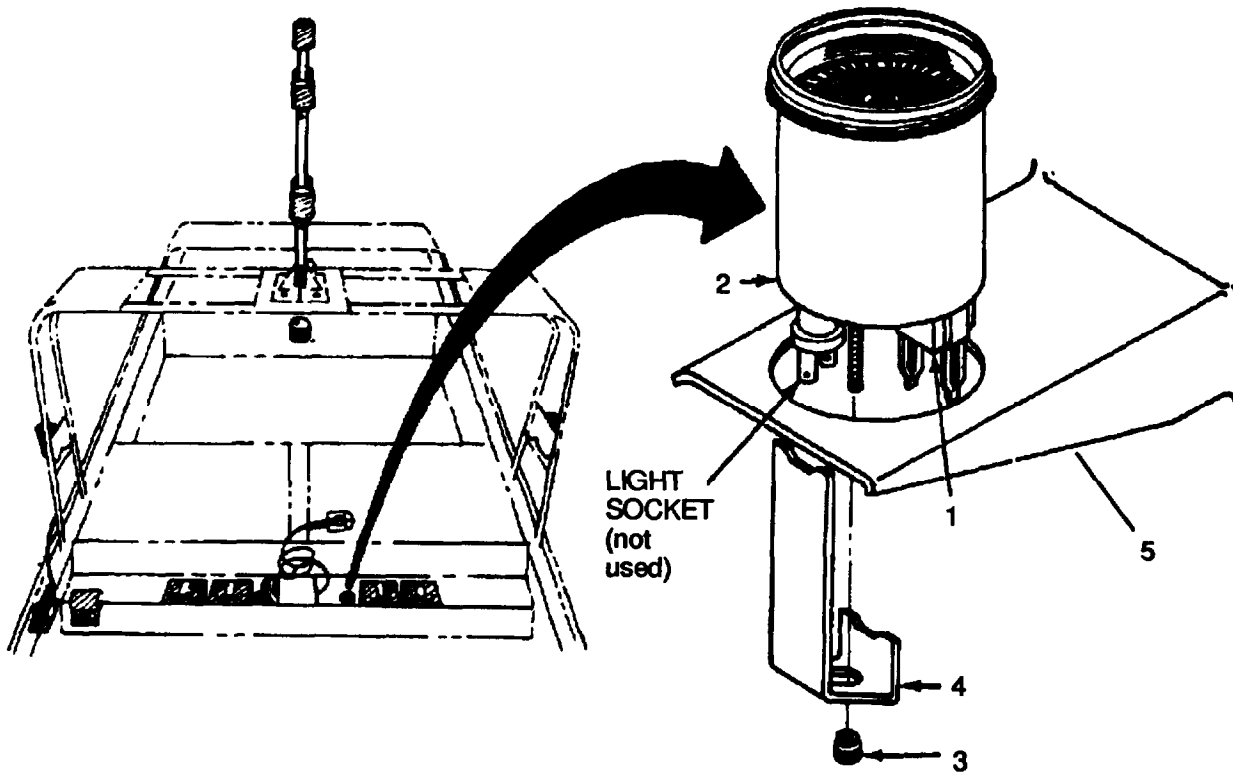

1. Open and secure battery hatch (refer to paragraph 3-154).
2. Disconnect batteries (refer to paragraph 3-89).
3. Disconnect quick-disconnect connectors (1) from base of engine hour meter (2).
4. Unscrew knurled nut (3) securing brace (4) to engine hour meter.
5. Remove engine hour meter from bracket (5).

INSTALL:

1. Place new engine hour meter (2) in bracket (5).
2. Replace brace (4) and secure with knurled nut (3).
3. Connect quick-disconnect connectors (1) on base of engine hour meter (2).
4. Reconnect batteries (refer to paragraph 3-89).
5. Close battery hatch.

3-114. SURGE PROTECTION UNIT TEST

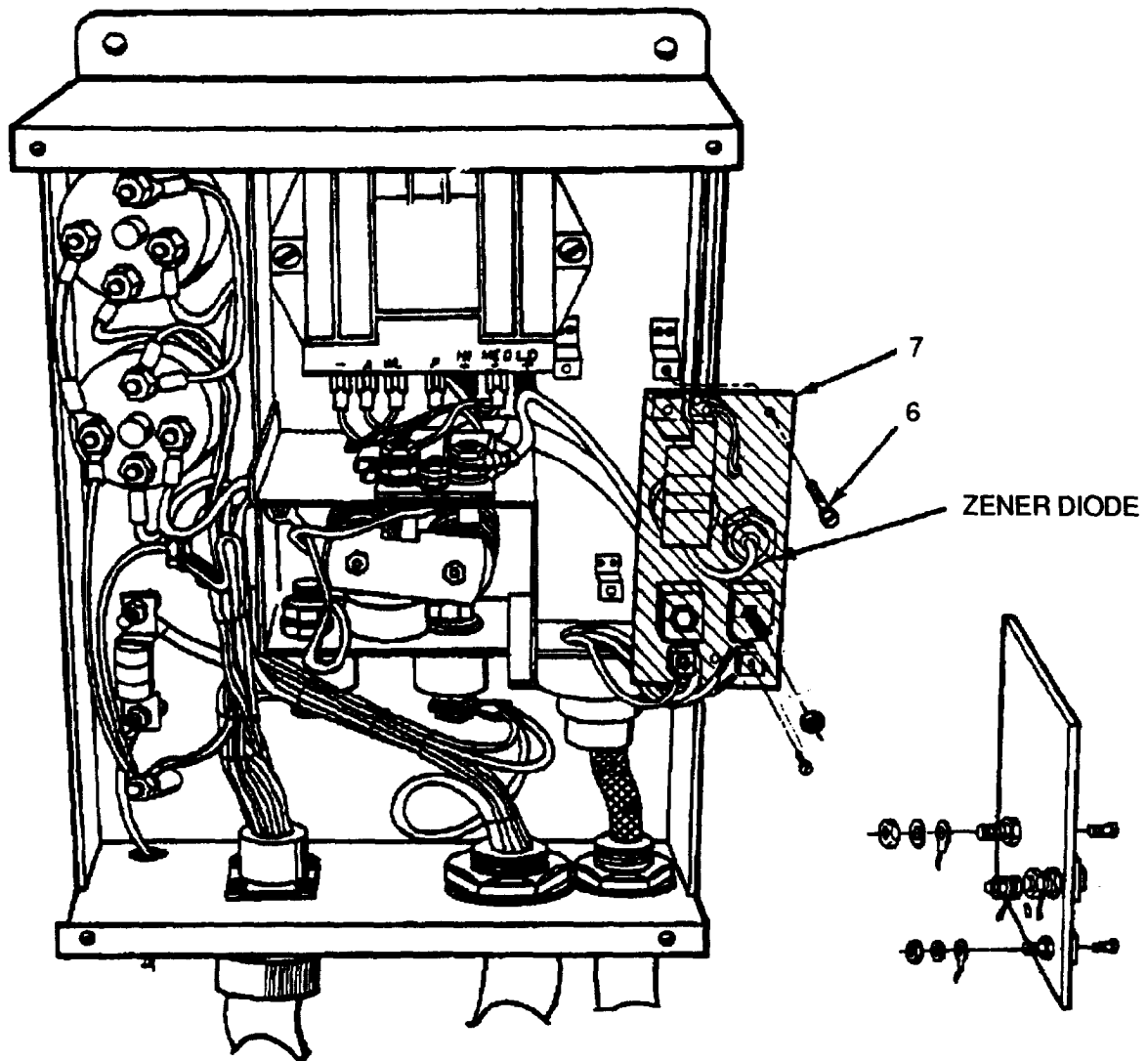

1. Remove three screws (6) fastening surge protection unit to box.
2. Move surge protection unit (7) to allow access to negative (-) terminal of diode on underside of unit.
3. Set multimeter to OHMS X1.
4. Connect meter to zener diode as shown in figure.

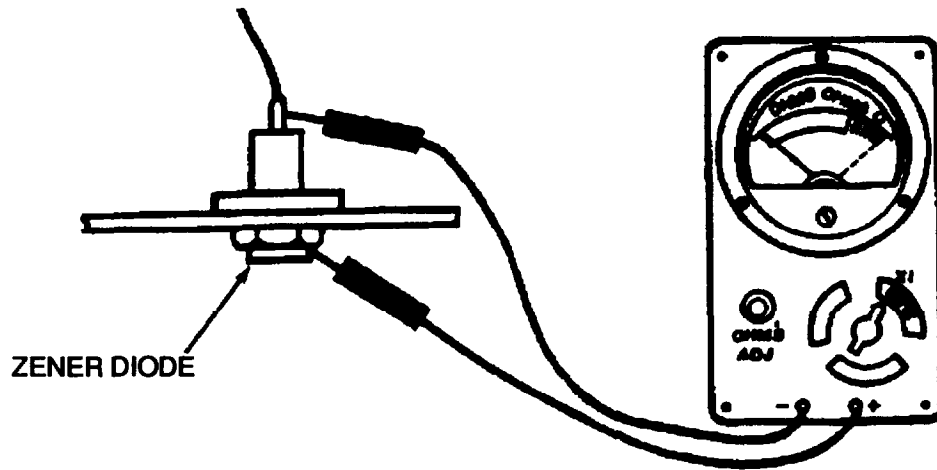

5. Look at meter and note reading.
6. Reverse the meter probes and note meter reading.
7. Compare meter reading obtained in steps 5 and 6.
 - If one meter reading was approximately 20 OHMS and the other reading was infinity (∞) the zener diode is good. Go to step 8.
 - If both meter readings were the same, the zener diode is bad. Replace control box (refer to paragraph 3-110).
8. The trouble is not in the surge protection unit. Fasten unit in place and go back to troubleshooting procedure for next instruction.
9. Replace voltage regulator cover with two screws (1) using flat tip screwdriver.

3-115. SOLENOID TEST

Start Solenoid or Thermostart Solenoid Test

1. Set multimeter to 50 volts DC.

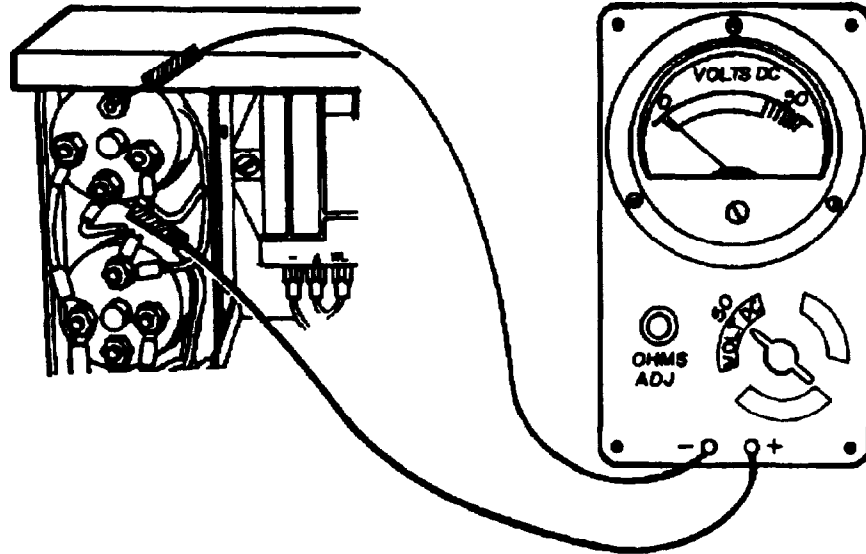

FIGURE A

2. Connect multimeter to solenoid (see Figure A).
3. Attempt start while looking at meter.
 - If meter reads approximately 24 volts, voltage is reaching solenoid. Go to step 4.
 - If meter reads zero (0) volts, voltage is not reaching solenoid. Go to step 6.

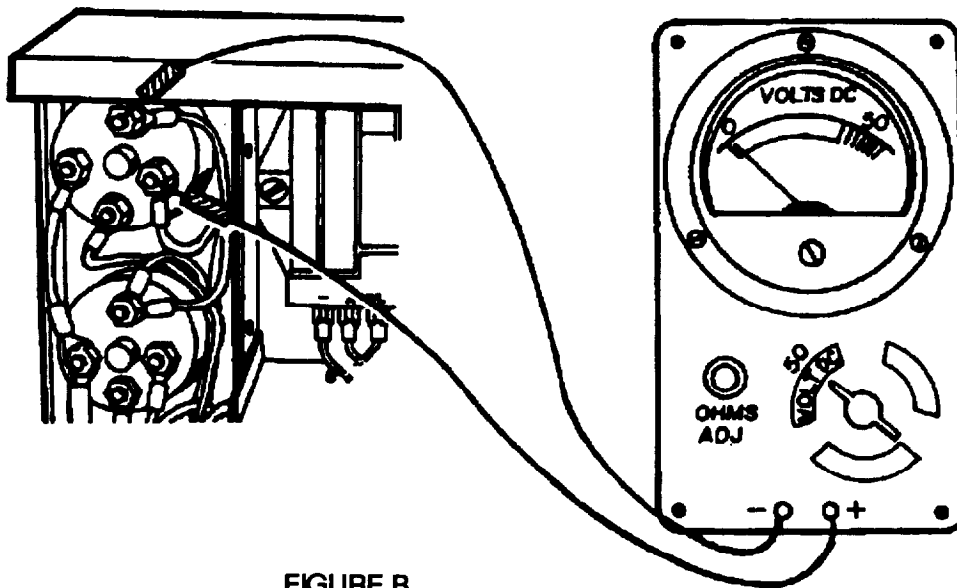
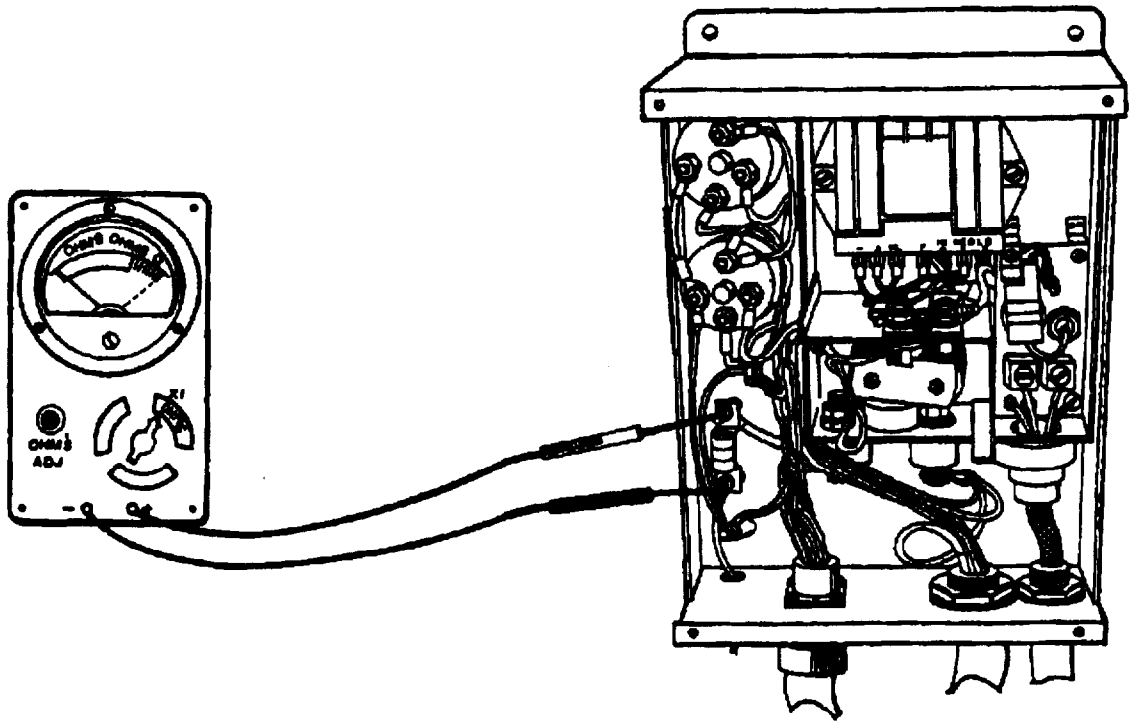

FIGURE B

4. Connect multimeter to solenoid (see Figure B).
5. Attempt start while looking at meter.
 - If meter reads 24 volts, the solenoid is good. Go to step 6.
 - If meter reads zero (0), the solenoid is bad. Replace control box (refer to paragraph 3-110).
6. Trouble is not in solenoid. Go back to troubleshooting procedure for next instruction.

3-116. FAST FUSE TEST



1. Set multimeter to OHMS X1. Zero meter (refer to paragraph 3-153).
2. Connect multimeter probes to fast fuse terminals and look at meter.
 - If resistance is zero (0), the fuse is good. Go to step 3.
 - If resistance is anything but zero (0), the fuse is bad. Replace fast fuse (refer to paragraph 3-118).
3. Trouble is not in fast fuse. Go back to troubleshooting procedure for next instruction.
4. Replace control box cover (refer to paragraph 3-110).

3-117. ENGINE CIRCUIT FUSE TEST

TOOLS: Multimeter
Cross-tip screwdriver

PARTS/MATERIALS: Fuse, 7.5 Amp

REMOVAL:

1. Using screwdriver, remove six screws (1).
2. Tilt control panel (2) forward.
3. Disconnect fuse holder (3) by pressing in and turning.
4. Remove fuse (4) from holder.

TEST:

1. Hold fuse up to light and see if bridge wire has been broken.
2. If not able to see broken bridge wire, make positive check as follows:
 - a. Set multimeter to OHMS x 100.
 - b. Hold probe to each end of fuse.
 - c. Reading means good fuse.
 - d. No reading means bad fuse.

INSTALLATION:

1. Put good fuse (4) into fuse holder (3).
2. Close fuse holder (3) by pressing together and twisting.
3. Position control panel (2).
4. Using screwdriver install six screws (1).

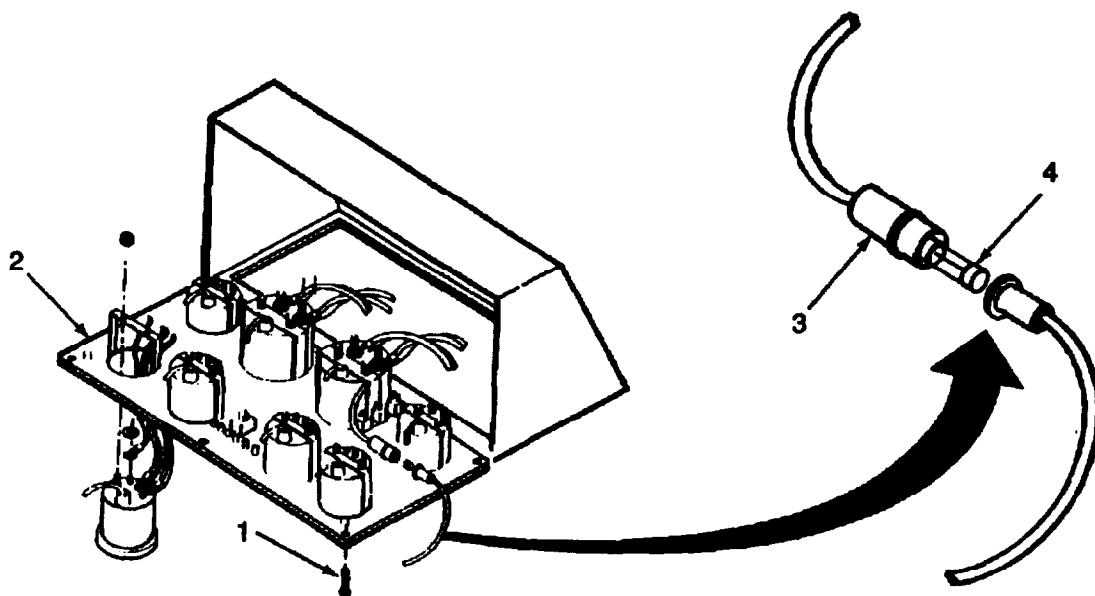

3-118. FAST FUSE REPLACEMENT INSTRUCTIONS

TOOLS: 10 mm Open End Wrench

PARTS/MATERIALS: Fast Fuse

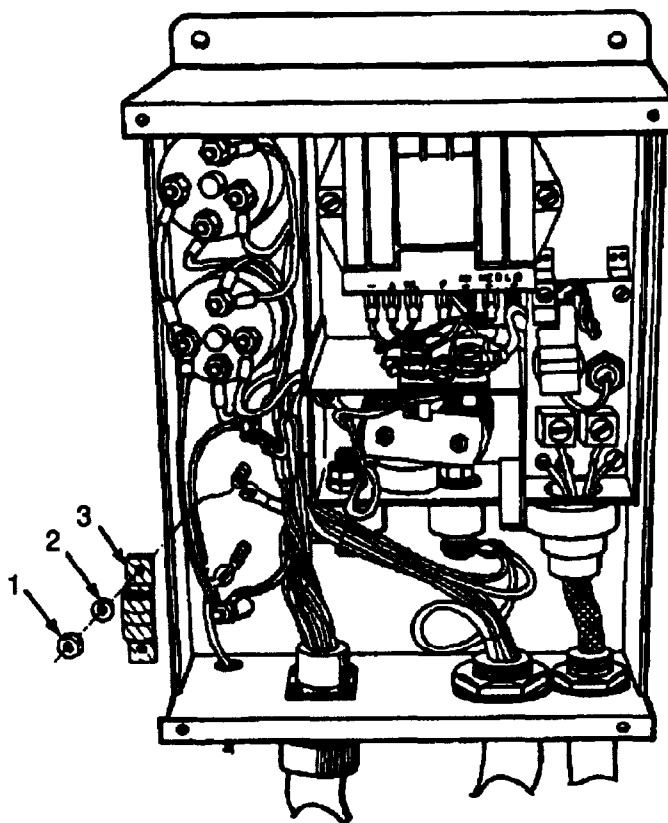

NOTE

Replacement of fast fuse is done when the fast fuse test, paragraph 3-116, indicates a faulty fuse.

REMOVE:

1. Using 10 mm open end wrench, remove two nuts (1) and lockwashers (2) securing fast fuse (3) to studs.
2. Remove fast fuse (3) and discard.

REPLACE:

1. Position fast fuse.
2. Using 10 mm open end wrench, reinstall two lockwashers (2) and nuts (1) securing new fast fuse (3) to studs.

3-119. ENGINE V-BELT REPLACEMENT INSTRUCTIONS

TOOLS: None

PARTS/MATERIALS: V-Belt

REMOVE:

1. Open and secure engine hatches (refer to paragraph 3-154).
2. Open and secure battery hatch (refer to paragraph 3-154).

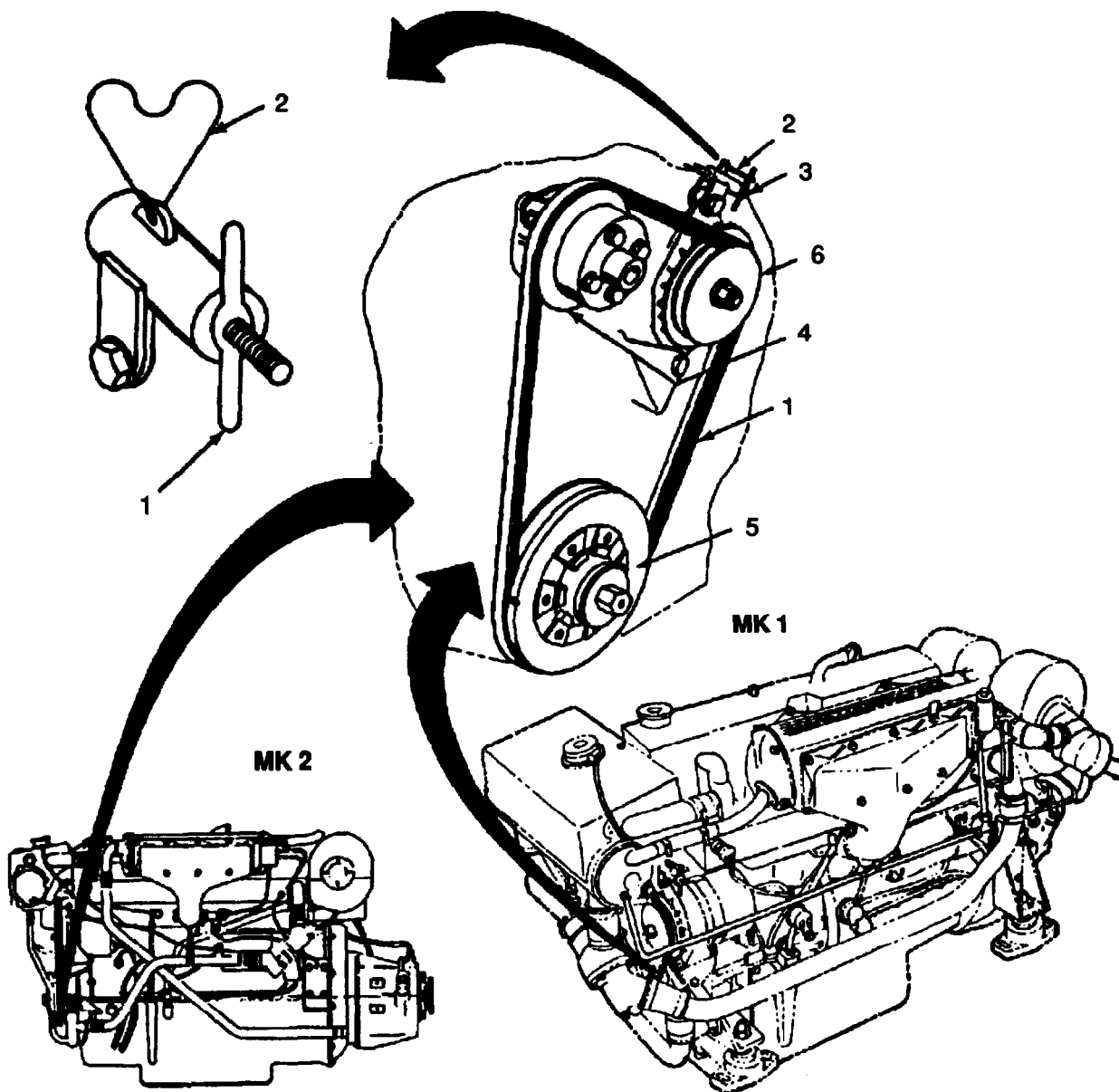

3. Release tension on V-belt (1) by releasing adjuster assembly lock (2) on alternator and turning adjuster mechanism (3).
4. Turn adjuster until V-belt (1) can be removed from pulleys (4, 5 and 6).
5. Discard old V-belt.

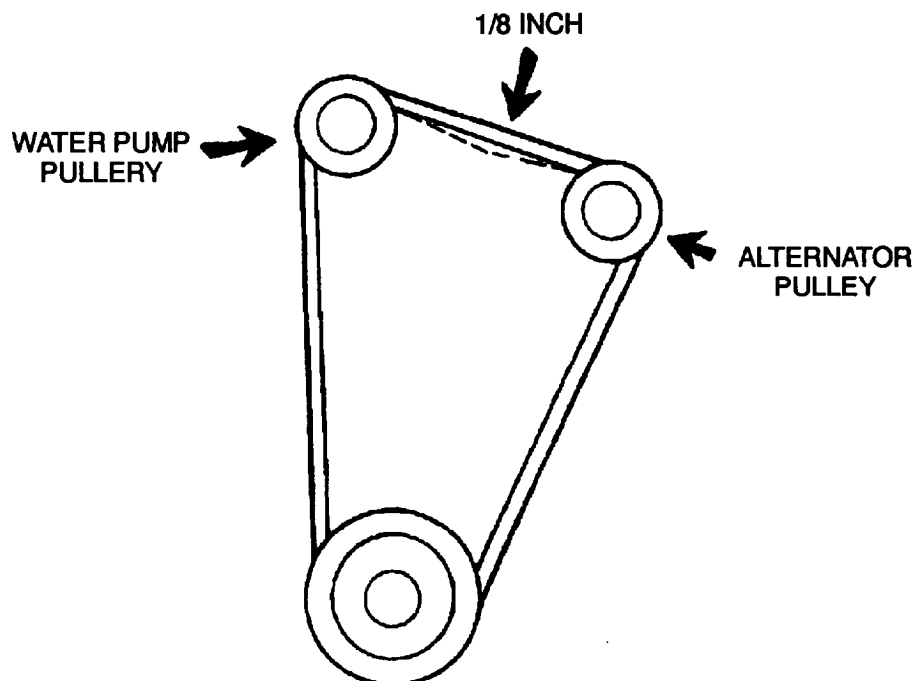

INSTALL:

1. Fit replacement V-belt (1) on water pump pulley (4), crankshaft pulley (5) and alternator pulley (6).
2. Using adjuster mechanism (3) on alternator turn adjuster to tighten V-belt until it can only be pushed in 1/8 inch between water pump pulley and alternator pulley as shown in figure.
3. Position adjuster mechanism (3) and apply adjuster lock (2).
4. Close battery hatch.
5. Close engine hatch.

3-120. STARTER TEST

TOOLS: Multimeter

1. Open and secure engine hatch (refer to paragraph 3-154).
2. Set multimeter to 50 volts DC.
3. Connect multimeter to starter terminals as shown in figure.
 - Negative (-) lead to R
 - Positive (+) lead to S

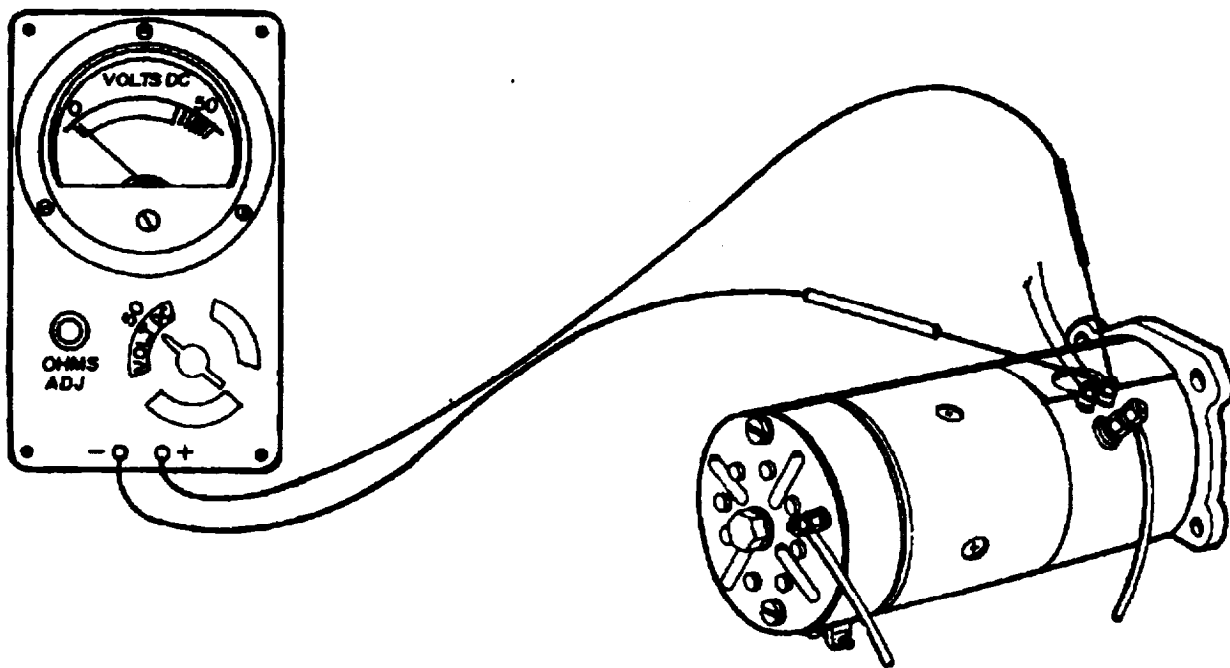

4. Attempt start while looking at meter.
 - If meter reads 24 volts and starter does not turn, starter is bad. Go to step 6.
 - If meter reads zero (0) volts, go to step 5.
5. Trouble is not in starter. Go back to troubleshooting procedure for next instruction.
6. Replace starter (refer to paragraph 3-121).

3-121. STARTER REPLACEMENT INSTRUCTIONS (PORT OR STARBOARD)

TOOLS: 8 mm Box Wrench
1/2 inch Box Wrench
11/16 inch Open End Wrench
9/16 inch Socket
Ratchet
2 inch Extension

PARTS/MATERIALS: Starter



Disconnect both sets of batteries to insure no power can get to starter. Severe burns or shock may result.

REMOVE:

1. Open and secure battery hatch (refer to paragraph 3-154).
2. Disconnect batteries (refer to paragraph 3-89).
3. Open and secure engine hatches (refer to paragraph 3-154).
4. Port starter replacement requires buoyancy flotation material removal (refer to paragraph 3-152).

5. Note wire locations on terminals of starter.
6. Using 11/16 inch wrench loosen nuts (1 and 2) and remove drain down tubing (3) (MK1 only).
7. Remove two nuts (4), washers (5) and wires from terminals (6) using 8 mm box wrench.
8. Remove two nuts (7), washers (8) and battery cables from terminals (9 and 10) using 1/2 inch box wrench.
9. Use socket with extension to remove three bob (11) and washers (12) securing starter (13) to flywheel housing.
Remove starter.

INSTALL:

1. Position end of starter (13) in opening of flywheel housing.
2. Aline starter mounting holes with holes in flywheel housing.
3. Install three washers (12) and bolts (11) and tighten with socket and extension.

NOTE

Battery cables have a lettered plastic clip for identification. Starter terminals are identified by letter stamped on starter at terminal.

4. Connect battery cable marked B or C to terminal (B+).
5. Connect battery cable marked F and C or K to terminal (R-).
6. Install two washers (8) and nuts (7) and tighten using 1/2 inch box wrench.
7. Install two wires on solenoid terminals (6) in accordance with tagging.
8. Install two washers (5) and nuts (4) and tighten using 8 mm box wrench.
9. Reinstall drain down tubing (3) and tighten nuts (1 and 2) using 11/16 inch wrench (MK1 only).
10. Replace buoyancy flotation material if removed (refer to paragraph 3-152).
11. Connect batteries (refer to paragraph 3-89).
12. Close hatches.

3-122. EXHAUST MANIFOLD REPLACEMENT INSTRUCTIONS

TOOLS: 1/2 inch Box Wrench
Flat Tip Screwdriver, 4 inch
9/16 in. Box Wrench
Putty Knife

PARTS/MATERIALS: Exhaust Manifold Gasket
Exhaust Manifold
Container

REMOVE:

1. Open and secure engine hatches (refer to paragraph 3-154).

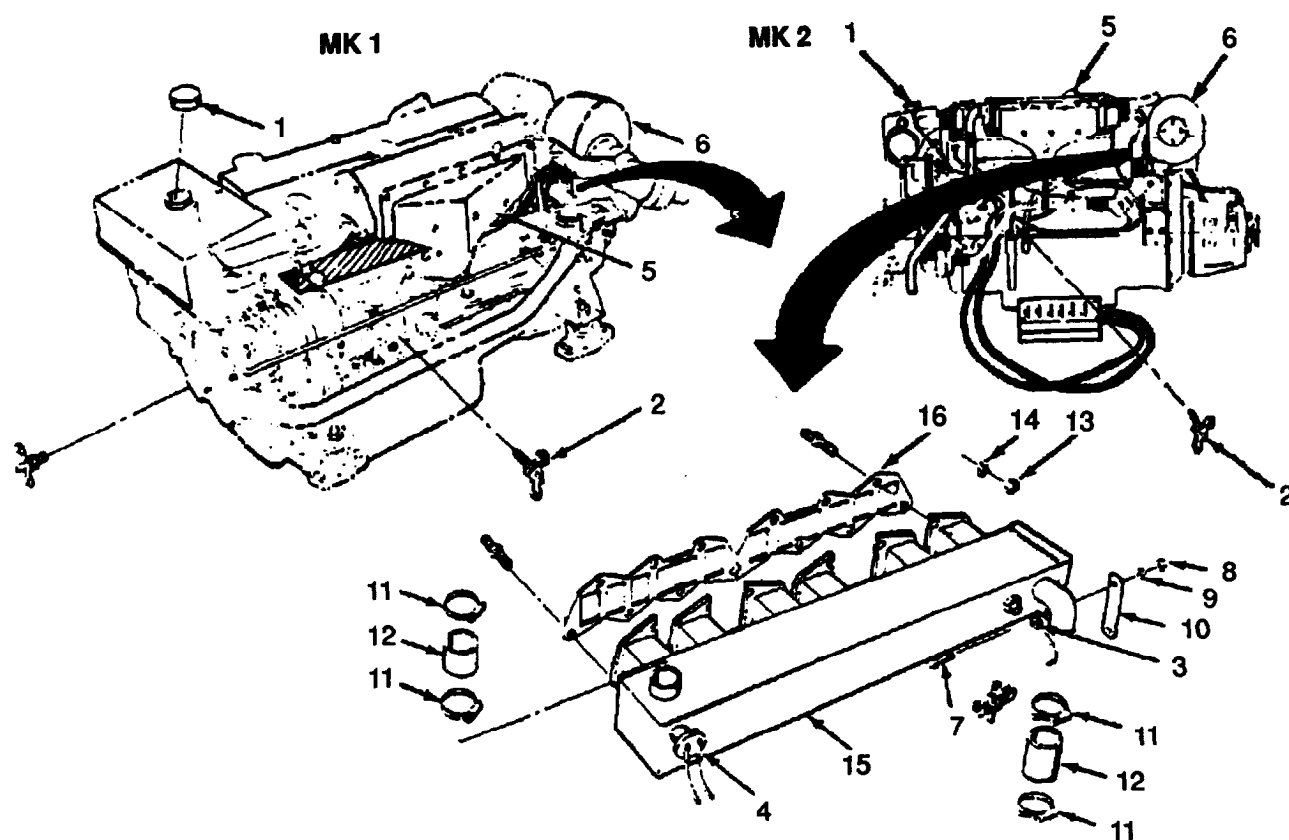

2. Remove fresh water filler cap (1).
3. Drain water from fresh water system at engine block drain (2) into a suitable container.
4. Disconnect water temperature sending unit (3).
5. Disconnect water high temperature switch (4).
6. Remove intercooler (5) (refer to paragraph. 3-83).

7. Remove turbocharger (6) (refer to paragraph 3-123).
8. Using 1/2 inch box wrench remove two bolts (7), nuts (8) and washers (9) securing pipe brace (10) on exhaust manifold to thermostat pipe.
9. Using screwdriver loosen hose clamps (11) securing hoses (12) to exhaust manifold.
10. Slide hoses free of exhaust manifold hose connections.
11. Using 9/16 inch box wrench remove eleven nuts (13) and washers (14) securing exhaust manifold to engine.
12. Remove exhaust manifold (15) from engine.
13. Using putty knife remove gasket (16).

INSTALL:

1. Install new exhaust manifold gasket (16).
2. Install new exhaust manifold (15) on engine block.
3. Using 9/16 inch box wrench reinstall eleven washers (14) and nuts (13) securing exhaust manifold (15) to engine.
4. Using 1/2 inch box wrench reinstall two bolts (7), washers (9) and nuts (8) securing pipe brace (10) on exhaust manifold to thermostat pipe.
5. Slide hoses (12) onto exhaust manifold hose connections.
6. Using screwdriver tighten hose clamps (11) securing hoses (12) to exhaust manifold hose connections.
7. Reconnect water high temperature switch (4).
8. Reconnect water temperature sending unit (3).
9. Close engine block water drain (2).
10. Reinstall intercooler (5) (refer to paragraph 3-83).
11. Reinstall turbocharger (6) (refer to paragraph 3-123).
12. Replace coolant, allowing an air space of approximately one inch at top of header tank
13. Reinstall fresh water filler cap (1).
14. Close engine hatches.

3-123. TURBOCHARGER REPLACEMENT INSTRUCTIONS

TOOLS: Flat Tip Screwdriver, 4 inch
1/2 inch Socket
Ratchet
6 inch Extension
9/16 inch Box Wrench
19 mm Open End Wrench
Putty Knife
5/8 inch Crowfoot Wrench

PARTS/MATERIALS: Turbocharger
Turbocharger Inlet Gasket
Turbocharger Outlet Gasket
Rags

PERSONNEL REQUIRED: Two

REMOVE:

1. Open and secure engine hatches (refer to paragraph 3-154).

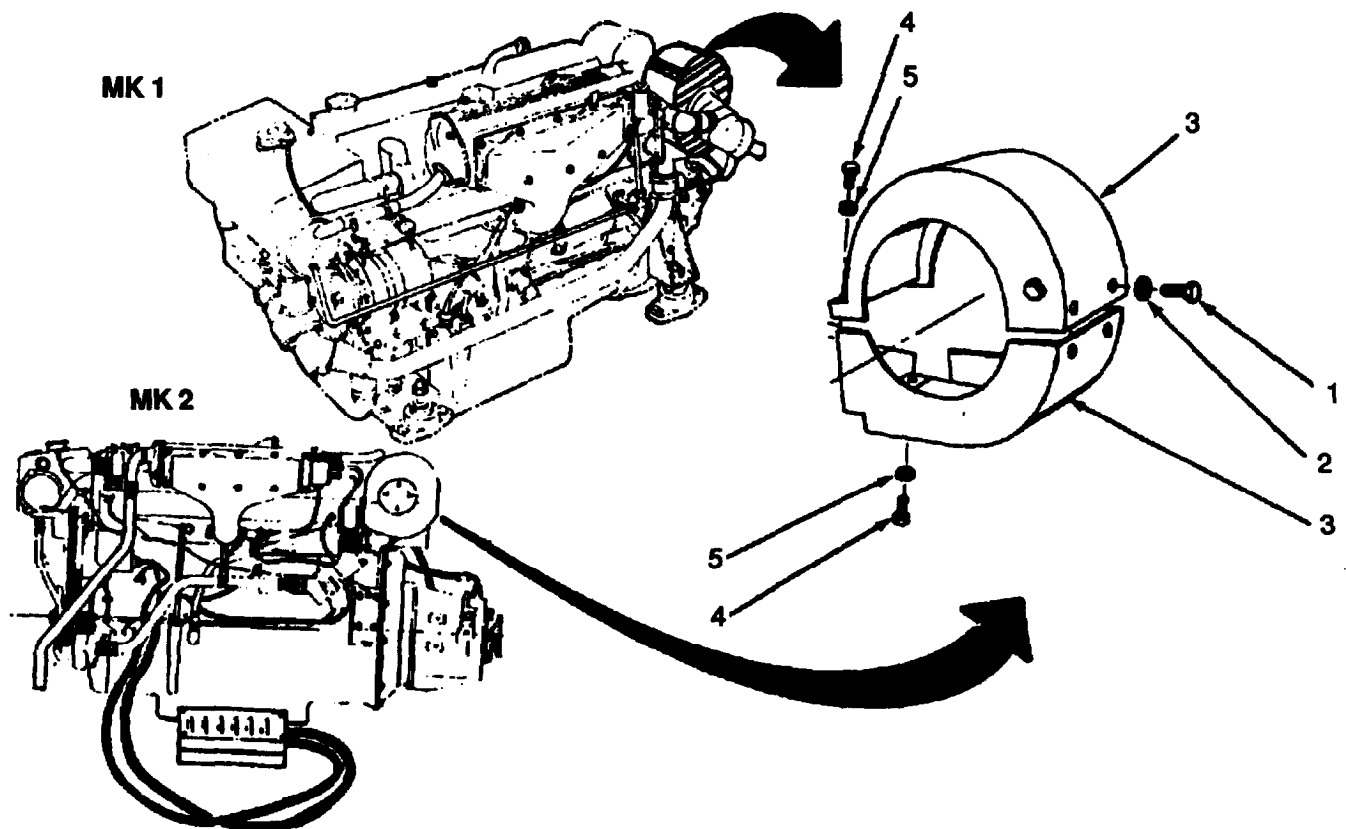

2. Using 1/2 inch socket remove three bolts (1) and washers (2) on aft end of heat shield (3).
3. Using 1/2 inch socket remove four bolts (4) and washers (5) securing turbocharger heat shield (3) to exhaust manifold.

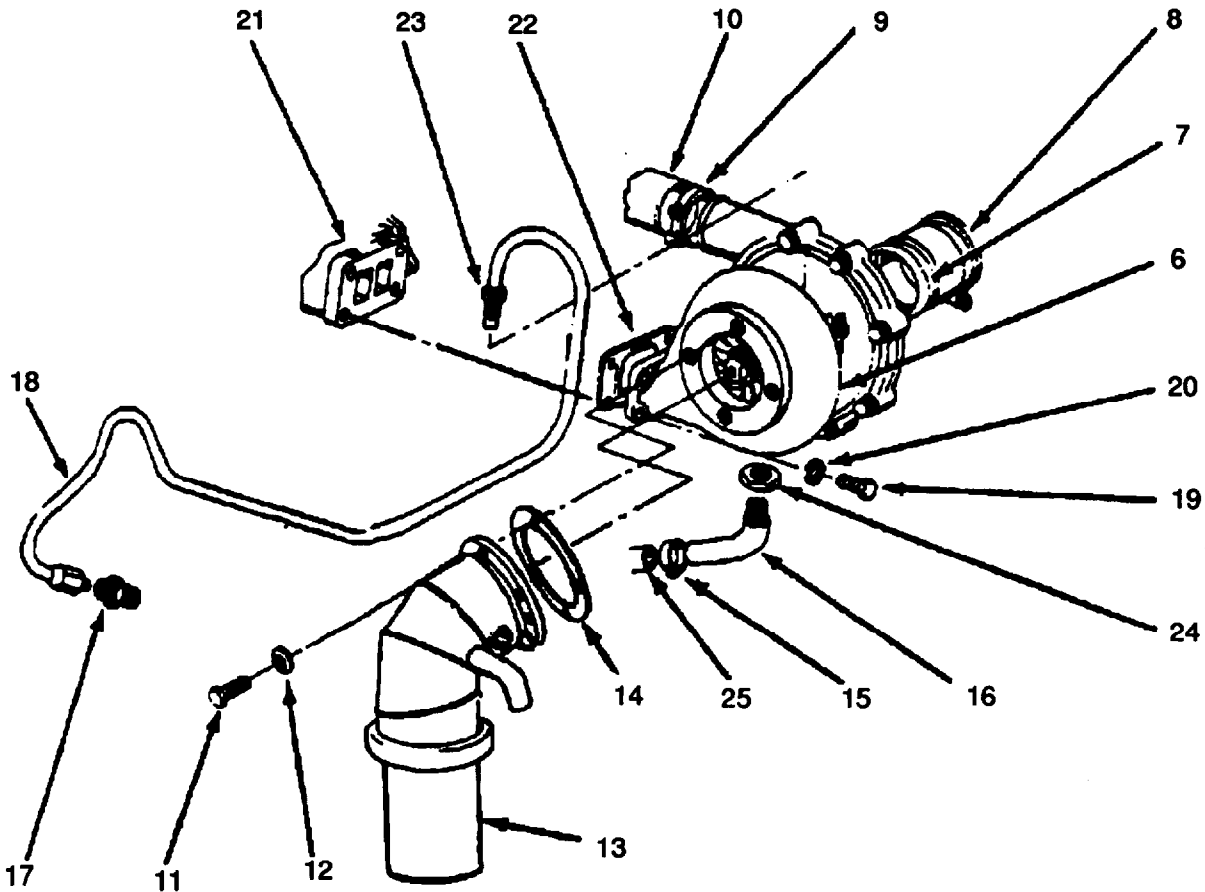

4. Remove heat shield (3) from turbocharger (6).
5. Using screwdriver loosen hose clamp (7) on turbocharger (6) to air intake hose (8).
6. Using screwdriver loosen hose clamp (9) on turbocharger (6) to intercooler hose (10).
7. Using 1/2 inch socket remove four bolts (11) and washers (12) securing exhaust elbow (13) to turbocharger (6).
8. Remove exhaust elbow (13) and gasket (14) from turbocharger (6). Using putty knife dean gasket material from exhaust elbow or exhaust return pipe and turbocharger.
9. Using screwdriver loosen hose damp (15) on turbocharger oil drain elbow (16).
10. Using 19 mm open end wrench remove fitting (17) connecting turbocharger oil feed pipe (18) to engine block.
11. Using 9/16 inch box wrench remove four bolts (19) and washers (20) securing turbocharger (6) to exhaust manifold (21).
12. Remove turbocharger (6) from engine. Remove gasket (22) and gasket material from exhaust manifold (21) and turbocharger (6) using putty knife.
13. Using 5/8 inch crowfoot wrench remove turbocharger oil feed pipe (18) and fitting (23) from turbocharger (6).
14. Using 1-1/4 inch crowfoot wrench remove turbocharger drain locknut (24) from turbocharger and remove turbocharger oil drain elbow (16).

INSTALL:

1. Connect turbocharger oil drain elbow (16) and locknut (24) on turbocharger (6). Tighten using 1-1/4 inch crowfoot wrench.
2. Connect turbocharger oil feed pipe (18) to turbocharger (6) and tighten fitting (23) using 5/8 inch crowfoot wrench. Orient feed pipe in direction shown in figure.
3. Fit gasket (22) and turbocharger (6) to exhaust manifold (21).
4. Install four washers (20) and bolts (19) loosely. Do not tighten at this time.
5. Connect air intake hose (8) to turbocharger (6). Do not tighten.
6. Connect drain pipe (25) to turbocharger oil drain elbow (16). Do not tighten.
7. Connect intercooler hose (10) to turbocharger (6). Do not tighten.
8. Tighten bolts (19) using 9/16 inch wrench.
9. Tighten hose clamp (7) using screwdriver.
10. Tighten hose clamp (9) using screwdriver.
11. Tighten hose clamp (15) using screwdriver.
12. Connect fitting (17) on turbocharger oil feed pipe (18) to engine block.
13. Tighten fitting (17) using 19 mm open end wrench.
14. Install gasket (14), exhaust elbow (13), and four washers (12) and bolts (11) on turbocharger (6).
15. Tighten bolts (11) using 1/2 inch socket.
16. Reinstall heat shield (3) over turbocharger (6).
17. Install four washers (5) and bolts (4) holding heat shield (3) to exhaust manifold (21).
18. Tighten bolts (4) using 1/2 inch socket.
19. Install three washers (2) and bolts (1) on heat shield (3).
20. Tighten bolts (1) using 1/2 inch socket.
21. Wipe spilled oil from engine parts.
22. Close engine hatches.

3-124. INJECTOR LINE AND FITTING REPLACEMENT INSTRUCTIONS

TOOLS: Cross Tip Screwdriver, No. 2
1-5/16 inch Open End Wrench
7/8 inch Open End Wrench
5/8 inch Open End wrench

PARTS/MATERIALS: Injector Line and Fitting

REMOVE:

1. Open and secure engine hatches (refer to paragraph 3-154).

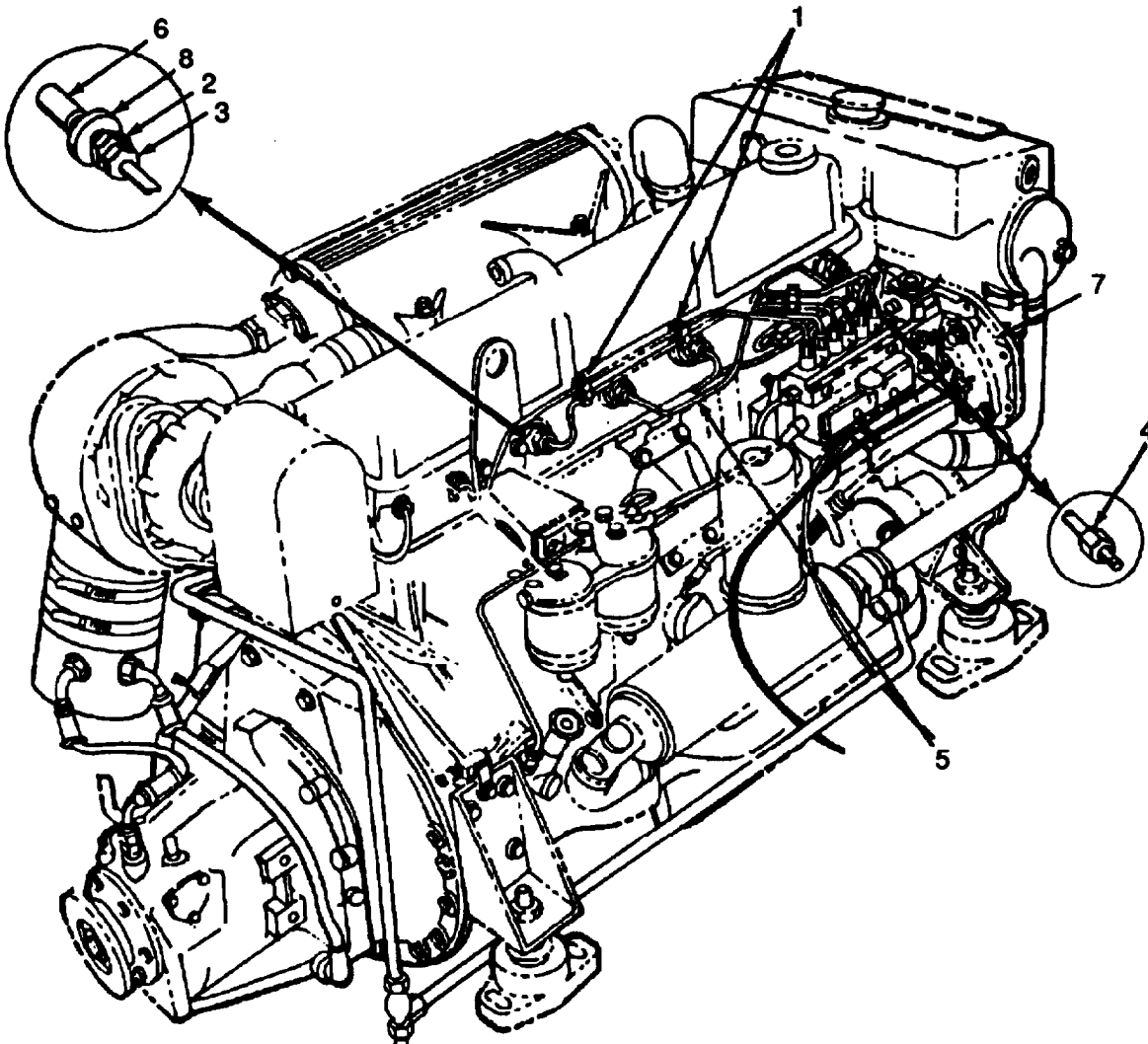

2. Using screwdriver remove injector pipe clamp(s) (1).
3. Using 1-5/16 inch open end wrench loosen oil seal retaining nut(s) (2).
4. Using 7/8 inch open end wrench disconnect fuel inlet adapter nut(s) (3).
5. Using 5/8 inch open end wrench disconnect nut(s) (4) securing injector line(s) (5) on injector pump (7).
6. Remove injector line(s) (5) and adapter assembly (6).
7. Remove oil seal with retainer (8) and discard oil seal.
8. Unscrew oil seal retainer nut (2).

INSTALL:

1. Holding fuel inlet adapter nut(s) (3) screw injector oil seal nut(s) (2) to extreme end of threads.
2. Push oil seal with retainer (8) onto fuel inlet adapter (6).
3. Position with new injector lines and fittings.
4. Screw in fuel inlet adapter (6). (Do not tighten.)
5. Using 5/8 inch open end wrench install nuts (4) securing injector lines (5) to injector pump (7).
6. Using 7/8 inch open end wrench tighten inlet adapter nut(s) (3).
7. With 1-5/16 inch open end wrench tighten injector oil seal nut(s) (2) until snug.
8. Using screwdriver reinstall injector pipe clamp (1).
9. Close engine hatches.

3-125. ENGINE VALVE COVER REMOVAL/INSTALLATION INSTRUCTIONS

TOOLS: Flat Tip Screwdriver, 4 inch
One Inch Putty Knife

PARTS/MATERIALS: Valve Cover Casket

REMOVE:

1. Open and secure engine hatches (refer to paragraph 3-154).

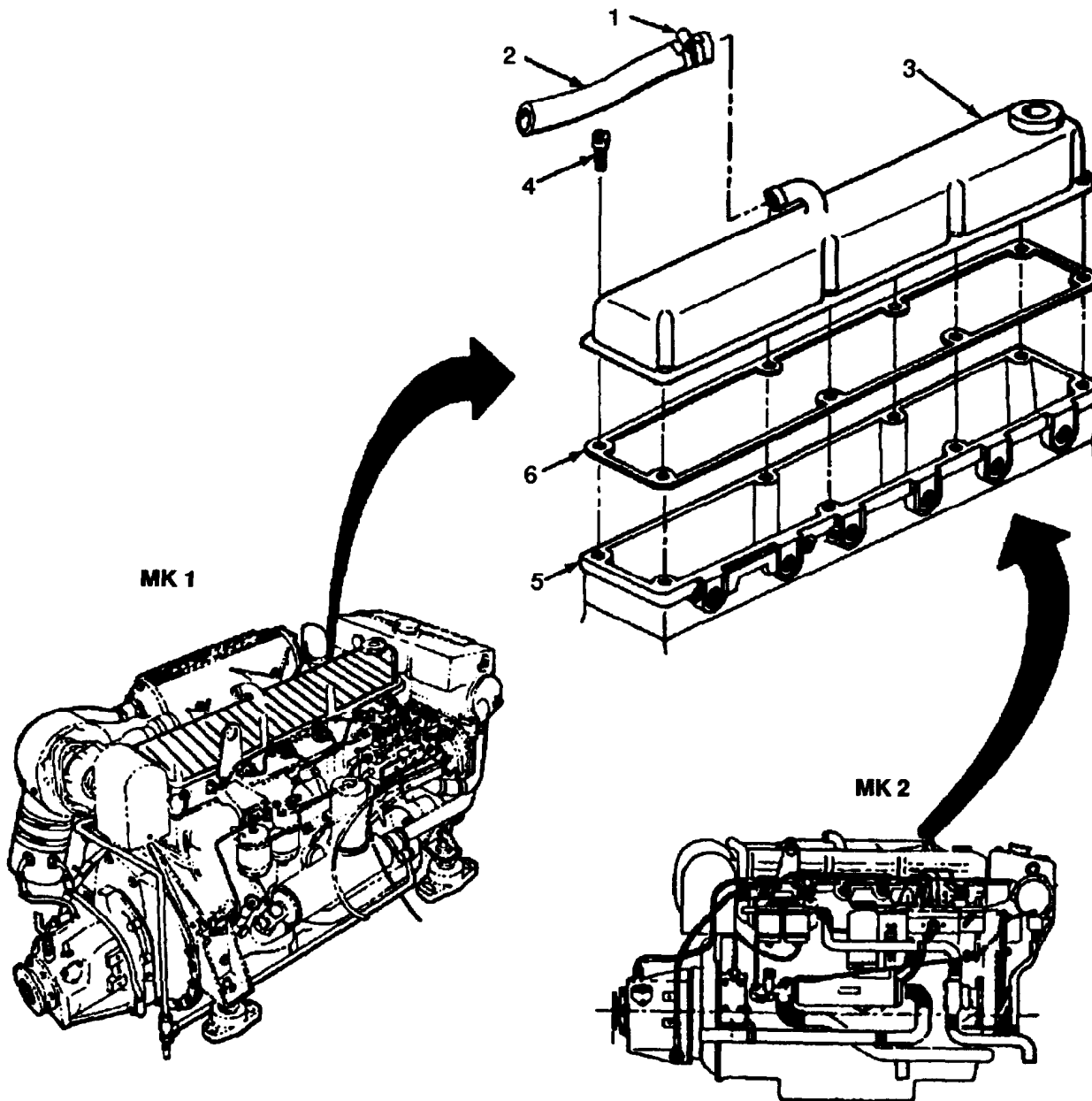

2. Using screwdriver loosen hose clamp (1) on breather hose (2).
3. Disconnect breather hose (2) from valve cover (3).
4. Using screwdriver remove eight screws (4) securing valve cover (3) to engine head (5).
5. Remove valve cover (3).

CAUTION

Don't let pieces of gasket fall into engine head.

6. Remove gasket (6) from engine head (5) and valve cover (3) using putty knife.

INSTALL:

1. Position gasket (6) on engine head (5) and align with mounting screw holes.
2. Mount valvecover (3) on engine head (5) being careful not to damage or dislodge gasket.
3. Secure valve cover (3) to engine head with eight screws (4).
4. Connect breather hose (2) to valve cover (3) and tighten clamp (1).
5. Close engine hatch covers.

3-126. ROCKER ARMS, SHAFT AND PUSH RODS INSPECTION AND REPLACEMENT INSTRUCTIONS

TOOLS: 9/16 inch Socket
7/16 inch Socket
Ratchet
Torque Wrench

PARTS/MATERIALS: Tags with String

PERSONNEL REQUIRED: Two

REMOVE:

1. Open and secure engine hatches (refer to paragraph 3-154).
2. Remove rocker arm cover (refer to paragraph 3-125).

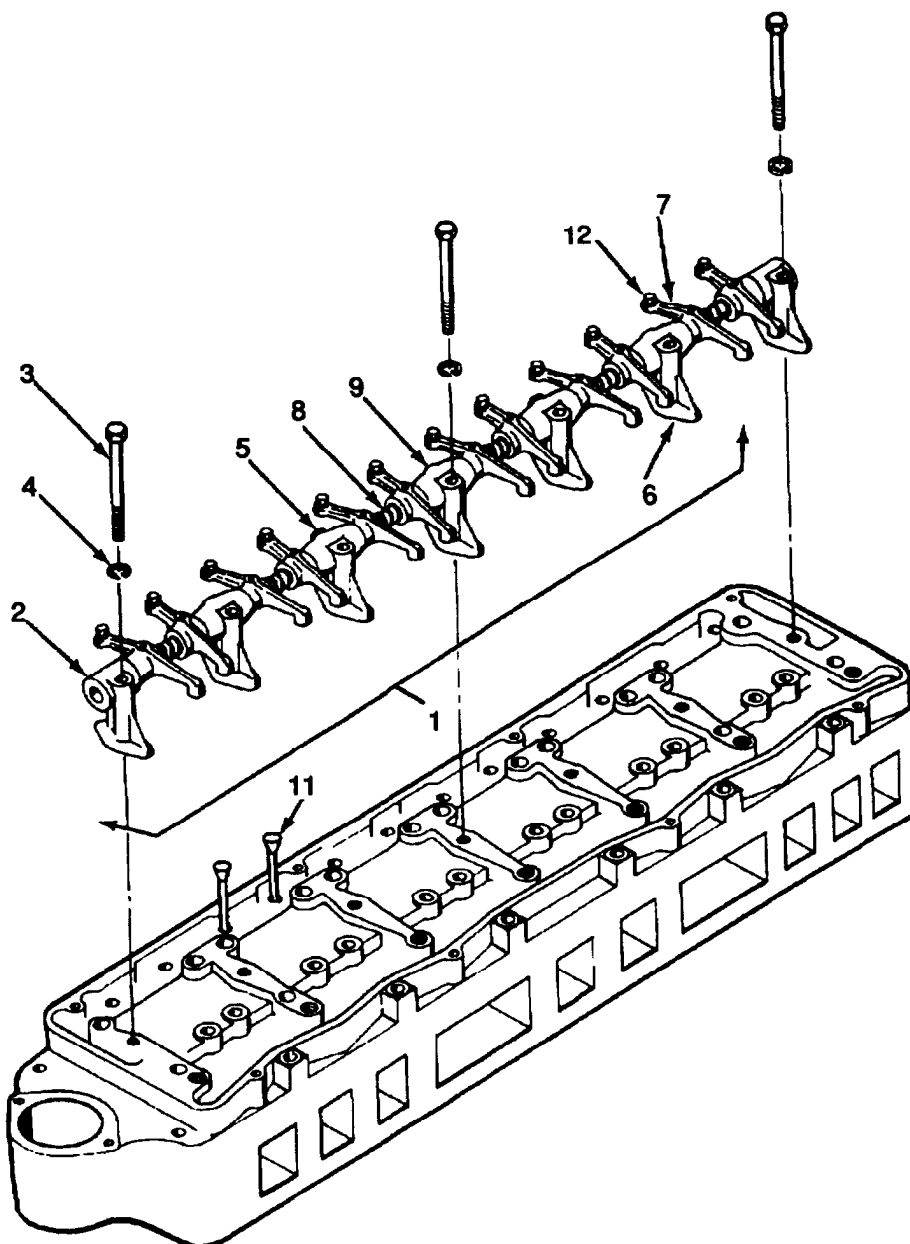

NOTE

Look at rocker arm assembly (1). Note the following:

- a) the assembly is spring loaded.
 - b) the rocker arms (7) are not alike.
 - c) the center rocker arm support (9) is solid and the intermediate rocker arm supports (6) have either a bolt (5) or a hole for a bolt.
 - d) a positioning bolt (5) is in the intermediate rocker arm support (6) to each side of the center rocker arm support (9).
 - e) the end rocker arm supports (2) are not like the other supports.
3. Number tags "1" through "12".
 4. Loosen all valve adjustment screws (12) and tie a tag to each rocker arm starting with "1" on the rocker arm nearest the header tank.

NOTE

Rocker arms must go back on the shaft in the same position they came from.

5. Using 9/16 inch socket remove bolts (3) and lockwashers (4) from center rocker arm support (9) and intermediate arm supports (6).

NOTE

One person holds the ends of the rocker arm assembly (1) together while the other person removes the final bolts. This will prevent the springs from pushing the assembly apart when the final bolts are removed.

6. Using 9/16 inch socket remove bolts (3) and lockwashers (4) from the end rocker arm supports (2).
7. Holding the ends together take assembly to workbench.
8. Using 7/16 inch socket loosen bolts (5) in two intermediate rocker arm supports.

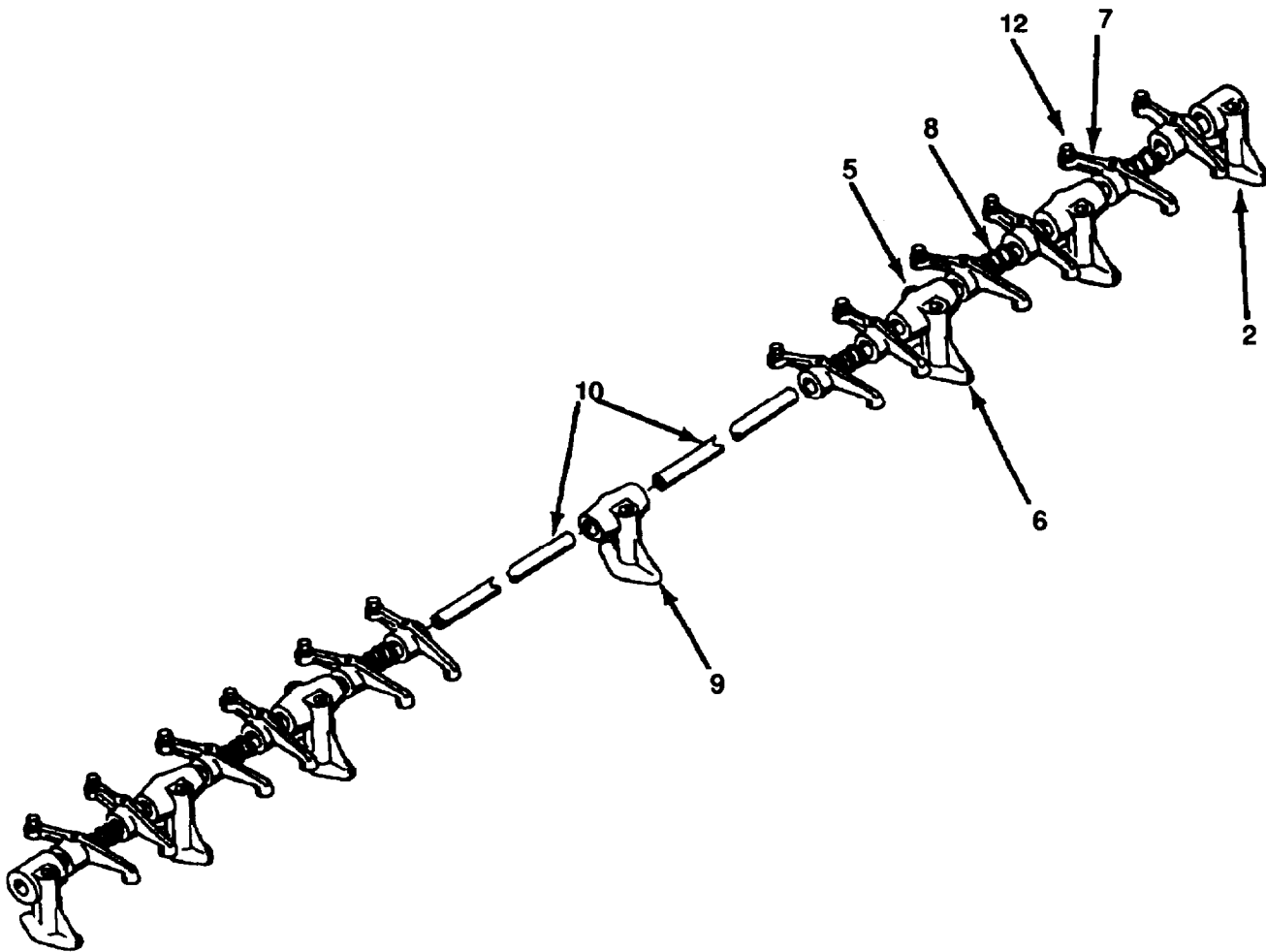

NOTE

Rocker shaft (10) is in two pieces.

9. Remove components from shaft.

NOTE

Keep components in order. They must go back on shaft in same order they come off.

INSPECT:

1. Inspect rocker arms (7) for cracks, breaks, surface wear or scoring. Replace rocker arms (7) if damage is detected. Transfer numbered tag to the new part.
2. Inspect rocker arm supports (2, 6 and 9) for cracks, breaks and other damage. Replace rocker arm supports (2, 6 and 9) if damage is detected.
3. Inspect for broken springs (8). Replace springs (8) if broken.
4. Inspect shafts (10) for cracks, breaks, surface wear or scoring. Replace shaft(s) (10) if damage is detected.

5. Takeout push rods (11) and inspect for warpage, cracks or breaks. Replace push rods (11) if damage is detected.
6. Reinstall push rods.

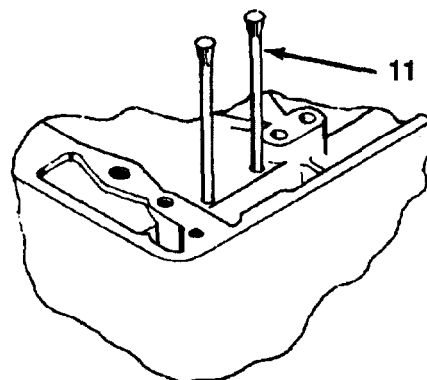

INSTALL:

1. Install bolts (5) through two intermediate rocker arm supports (6) into tapped holes in shaft (10).
2. Tighten bolts (5) using 7/16 inch socket.

NOTE

Components must go back on shaft in the same order they came off.

3. Install remaining components (2, 6, 7, 8 and 9), in order, using tagged rocker arms as guides, onto rocker arm shaft (10).
4. Hold assembly together by the ends and take it to the cylinder head.

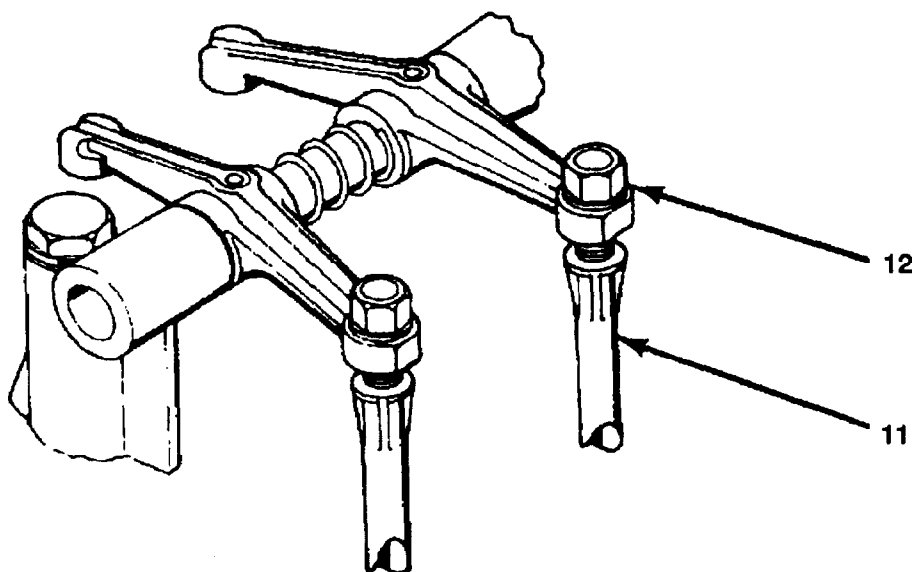

5. As one person holds the assembly (1) in place the other person installs lockwashers (4) and bolts (3) into end rocker arm supports (2) and into cylinder head making sure that capped ends of push rods (11) engage adjusting screw (12) in rocker arms.
6. Using 9/16 inch socket reinstall remaining five lockwashers (4) and bolts (3) to hold rocker shaft assembly (1) to cylinder head.
7. Tighten each bolt in turn 1/2 turn in order to seat assembly evenly as valve spring pressure is taken up.
8. Torque all seven bolts (3) to 17 - 22 ft-lb (23 to 29.8 N·m).
9. Adjust valve tappets (refer to paragraph 3-128).
10. Replace rocker arm cover (refer to paragraph 3-125).
11. Close engine hatch covers.

3-127. INJECTOR REPLACEMENT INSTRUCTIONS

TOOLS: Flat Tip Screwdriver, 4 inch
5/8 inch Open End Wrench
7/8 inch Open End Wrench
7/16 inch Open End Wrench
1-5/16 inch Open End Wrench
Cross Tip Screwdriver, No. 2
1/2 inch Open End Wrench
1/2 inch Socket
6 inch Socket Extension
Torque Wrench
Ratchet

PARTS/MATERIALS: New Injectors
New Rocker Cover Gasket
New Copper Washers
New Oil Seal

PERSONNEL REQUIRED: Two

REMOVE:

1. Open and secure engine hatches (refer to paragraph 3-154).

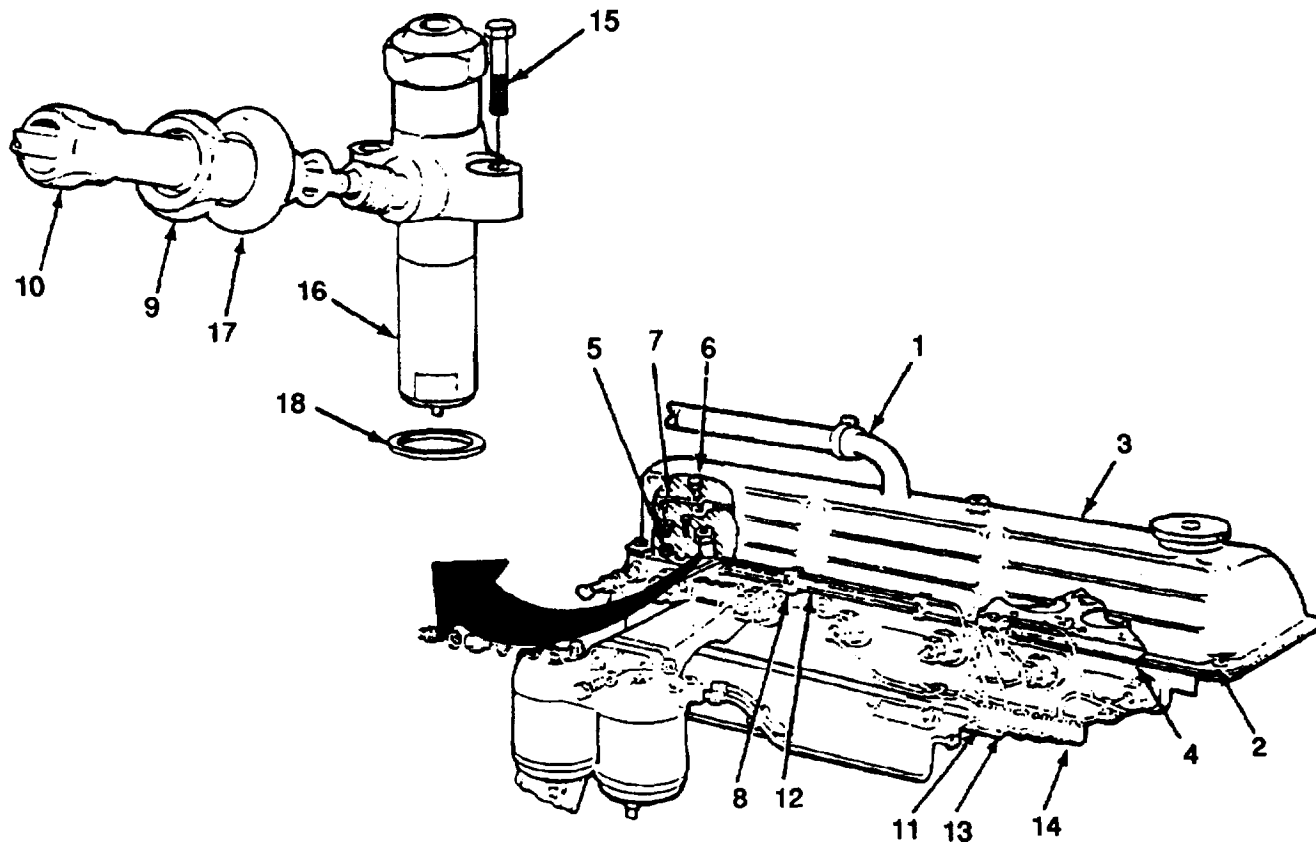

2. Using flat tip screwdriver loosen clamp (1) on hose to breather pipe. Disconnect hose.
3. Using flat tip screwdriver remove eight screws (2) securing rocker cover.
4. Remove rocker cover (3) and gasket (4) (refer to paragraph 3-125). Remove rocker arm assembly (refer to paragraph 3-126).
5. Using 7/16 inch open and wrench disconnect union nut (5) on injector fuel return line (7).
6. Using 7/16 inch open end wrench remove six injector bolts (6) connecting injector fuel return line (7) to injectors.
7. Remove injector fuel return line (7).
8. Using cross tip screwdriver remove injector pipe clamps (8).
9. Using 1-5/16 inch open end wrench loosen oil seal retaining nut(s) (9).
10. Using 7/8 inch open end wrench, disconnect fuel inlet adapter nut(s) (10).
11. Using 5/8 inch open end wrench disconnect connector nut(s) (11) on injector pump.
12. Remove injector pipes (12) and oil seal(s) with retainer (13). Discard oil seal(s).
13. Cover injector pump connector(s) (14) to eliminate dirt contamination.
14. Using 1/2 inch socket and ratchet remove bolts(s) (15) securing injector(s) to cylinder head.
15. Remove injectors (16). If copper washer (17) does not dome out of injector remove it from injector port. (Take care no dirt falls into injector port.)
16. Cover injector ports to eliminate dirt contamination.

INSTALL:

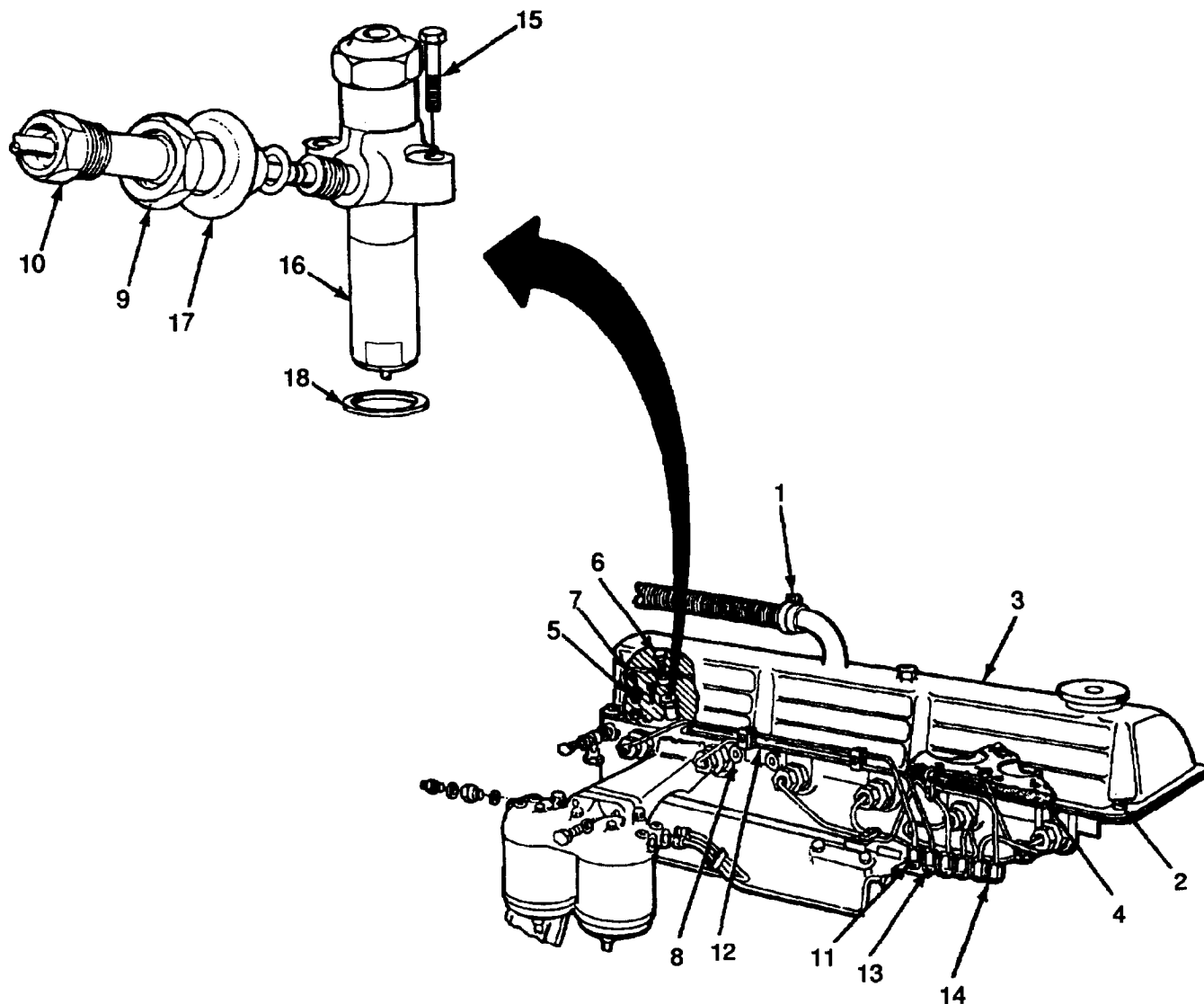

1. Install copper washers (18) on injector (16) and install injector(s) (16).
2. Using 1/2 inch socket extension and torque wrench install bolt(s) (15) securing injector(s) (16) to cylinder head. Torque to 14 to 16 ft/lb.
3. Holding inlet adapter nut(s) (10), unscrew injector oil seal nut(s) (9) to the extreme end of the threads.
4. Fit oil seal with retainer (17) onto inlet adapter nut (10).
5. Position injector pipe(s) (12) to pump (13).

6. Screw fuel adapter nut (10) to injector (16). Do not tighten.
7. Screw connector nut(s) (11) to connector (14) and tighten using 5/8 inch wrench.
8. Tighten fuel inlet adapter nut (10) using 7/8 inch wrench.
9. With 1-5/16 inch open end wrench tighten injector oil seal nut(s) (9) until snug.
10. Using cross tip screwdriver reinstall injector pipe clamp(s) (8).

CAUTION

Do not bend or twist RAIL LINE(s) (7). To do so will cause injector leakage.

11. Carefully thread Bolt(s) (6) into injector rail line(s) (7) observing caution above and seat bolt and line finger tight to injector (16).
12. Using 7/16 inch socket wrench torque bolt(s) (6) to 14-16 ft-lb.
13. Using 7/16 inch open end wrench tighten union nut (5) connecting injector fuel return line (7).
14. Install rocker arm assembly and adjust tappets (refer to paragraph 3-126).
15. Install new gasket (4) on cylinder head.
16. Reinstall rocker cover (3) and insure that gasket (4) is correctly positioned. (refer to paragraph 3-125).
17. Using flat tip screwdriver reinstall eight screws (2) securing rocker cover.
18. Reconnect breather hose to rocker cover (3) and tighten clamp (1) using flat tip screwdriver.
19. Close engine hatches.

3-128. ENGINE VALVE TAPPETS ADJUSTMENT INSTRUCTIONS

TOOLS: 7/16 inch Socket
Ratchet
15/16 inch Box Wrench
Feeler Gage Set

PARTS/MATERIALS: Rocker Cover Gasket

WARNING

Engine Stop Control must be pulled out to prevent accidental engine starting during tappet adjustment or personal injury may result.

NOTE

Cold valve adjustment is .019 inch (.483 mm). Hot valve adjustment is .018 inch (.457 mm). Normal adjustment procedures should be done with the engine hot.

1. Open and secure engine hatches (refer to paragraph 3-154).
2. Remove engine rocker arm cover (refer to paragraph 3-126).

NOTE

The engine valves are numbered from front (header tank end) to rear (flywheel end).

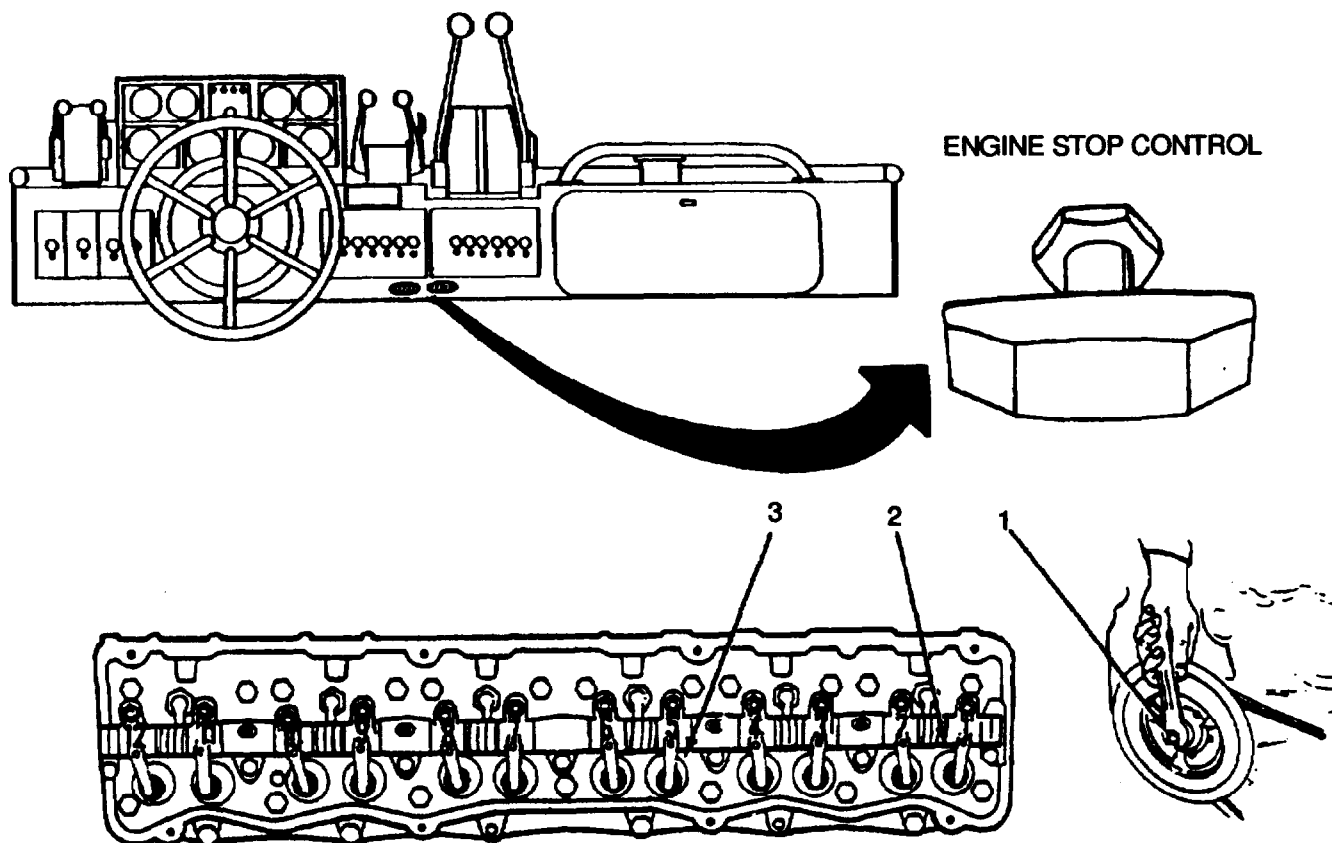

3. Using 15/16 inch open end wrench placed on nose bolt (1) of crankshaft pulley turn engine counterclockwise until valves number 1 (2) and 4 (3) are opened by their respective rocker arms. Valves are open when rocker arm has pushed valve stem cap down as far as possible.

4. Valve will be adjusted in sequence as shown below:

Valves Open

- 1 and 4
- 8 and 10
- 2 and 6
- 9 and 12
- 3 and 5
- 7 and 11

Valves to Adjust

- 9 and 12
- 3 and 5
- 7 and 11
- 1 and 4
- 8 and 10
- 2 and 6

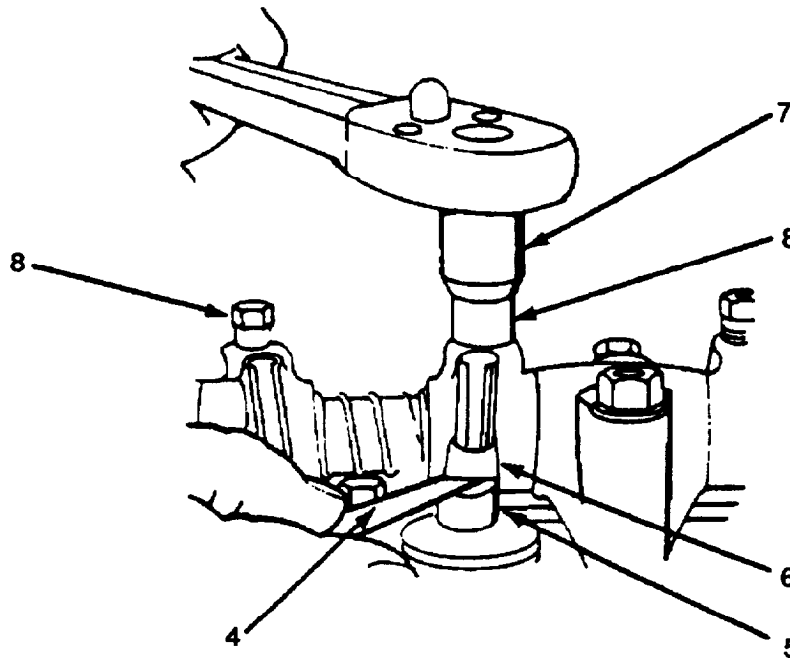

5. To adjust valve number 9, insert .018 inch feeler gage (4) between valve stem cap (5) and rocker arm (6) of valve number 9.
6. Place socket (7) on adjusting screw (8) and rotate screw until feeler gage is lightly caught between rocker arm (6) and valve stem cap (5) of valve being adjusted. Feeler gage should meet with only slight drag. Remove feeler gage (4) and socket (7).
7. Repeat procedure for valve number 12.
8. Rotate engine until valves 8 and 10 are open. Valves 3 and 5 may now be adjusted as in preceding steps 7 and 8.
9. Repeat steps 7 and 8 until all valves have been adjusted, following sequence in step 6.
10. Replace engine rocker arm cover (refer to paragraph 3-125).
11. Close engine hatches.

3-129. CRANKSHAFT PULLEY REPLACEMENT INSTRUCTIONS

TOOLS: 15/16 inch Box Wrench
Mechanical Puller

PARTS/MATERIALS: Crankshaft Pulley
Oil

REMOVE:

1. Open and secure engine hatches (refer to paragraph 3-154).
2. Open and secure battery hatch (refer to paragraph 3-154).

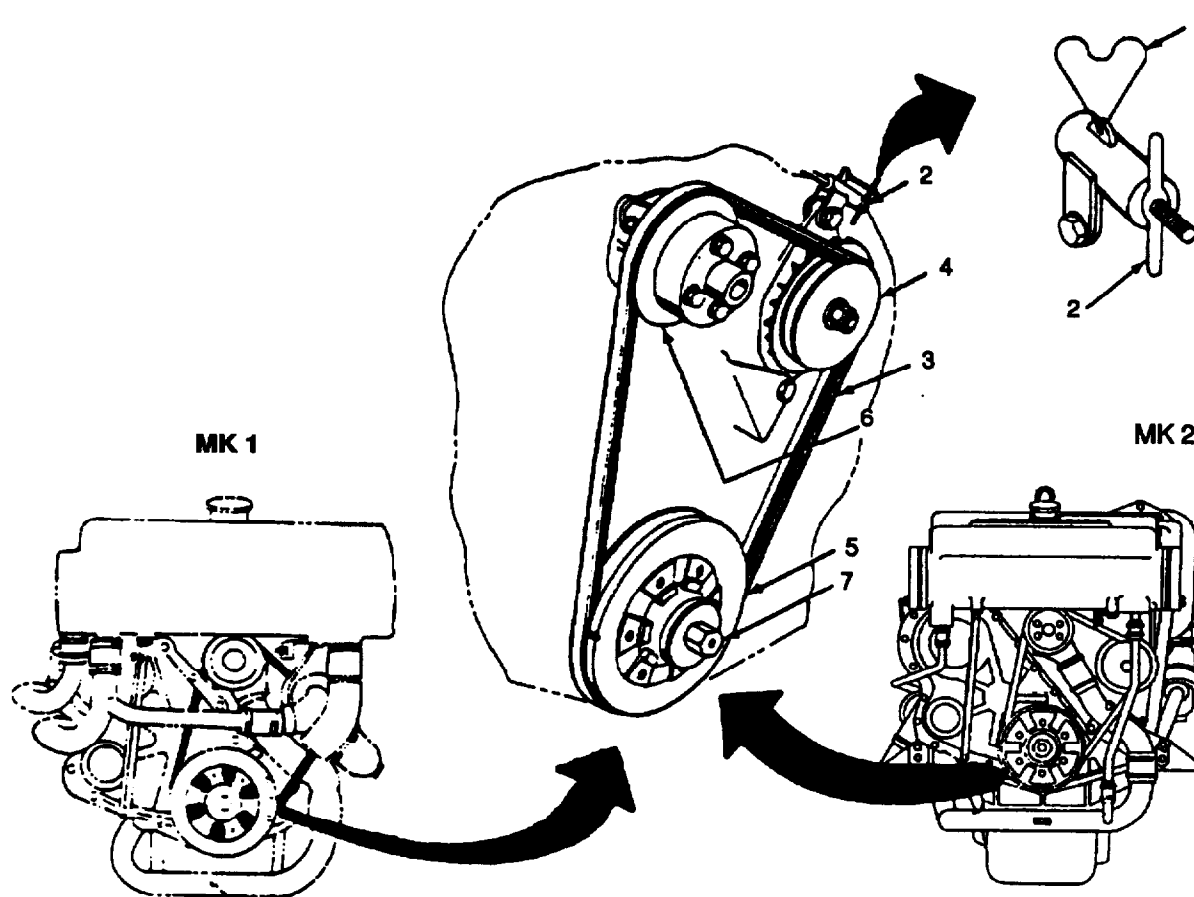

3. Loosen tension on V-belt (3) by releasing adjuster assembly lock (1) on alternator and turning adjuster (2) clockwise.
4. Remove V-belt (3) from pulleys. Check for cracks, breaks and fraying. Replace it necessary.

5. Using 15/16 inch wrench remove nose bolt (7) from crankshaft.
6. Using mechanical puller remove pulley (5) from crankshaft.

NOTE

Take care when removing key not to lose it.

7. Clean and inspect nose bolt (7) and pulley mounting surface of crankshaft.
8. Insure key is fitted to keyway on crankshaft.

INSTALL:

1. Lubricate end of crankshaft with oil for easy fit.
2. Fit replacement pulley (5) to crankshaft insuring alinement of key and keyway.
3. Install nose bolt (7) and tighten using wrench.
4. Fit V-belt (3) on water pump pulley (6), crankshaft pulley (5) and alternator pulley (4).

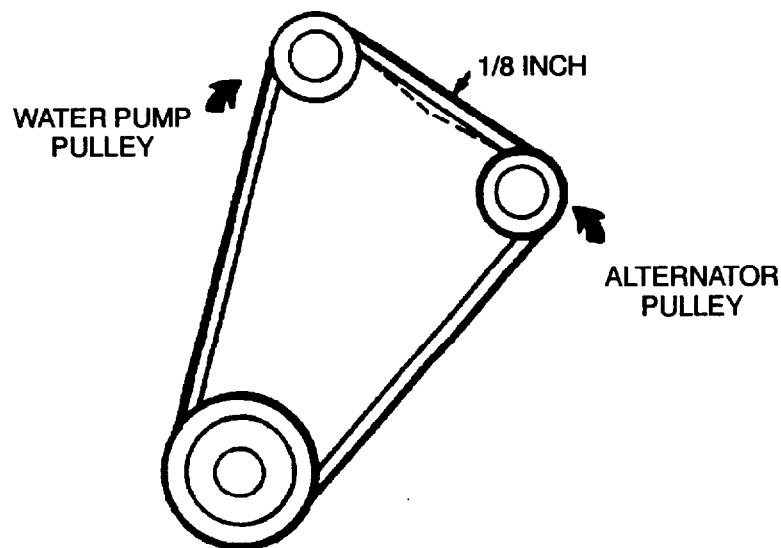

5. Using adjuster mechanism (2) on alternator turn adjuster and tighten V-belt. Tighten belt until the free movement between the water pump pulley and alternator when pushed is not in excess of 1/8 inch as shown in figure.
6. Position adjuster mechanism (2) and apply adjuster lock (1).
7. Close battery hatch.
8. Close engine hatch.

3-130. FLYWHEEL AND STARTER RING GEAR INSPECTION INSTRUCTIONS

TOOLS: 15/16 inch Box Wrench
Inspection Mirror
1/2 inch Box Wrench
Flashlight

PARTS/MATERIALS: None

PERSONNEL REQUIRED: Two

INSPECT:

1. Open and secure engine hatches (refer to paragraph 3-154).
2. Open and seam battery hatch (refer to paragraph 3-154).

NOTE

If starboard flywheel and starter ring gear are to be inspected remove buoyancy flotation material (refer to paragraph 3-152). There is no requirement to remove buoyancy flotation material to inspect port flywheel and starter ring gear.

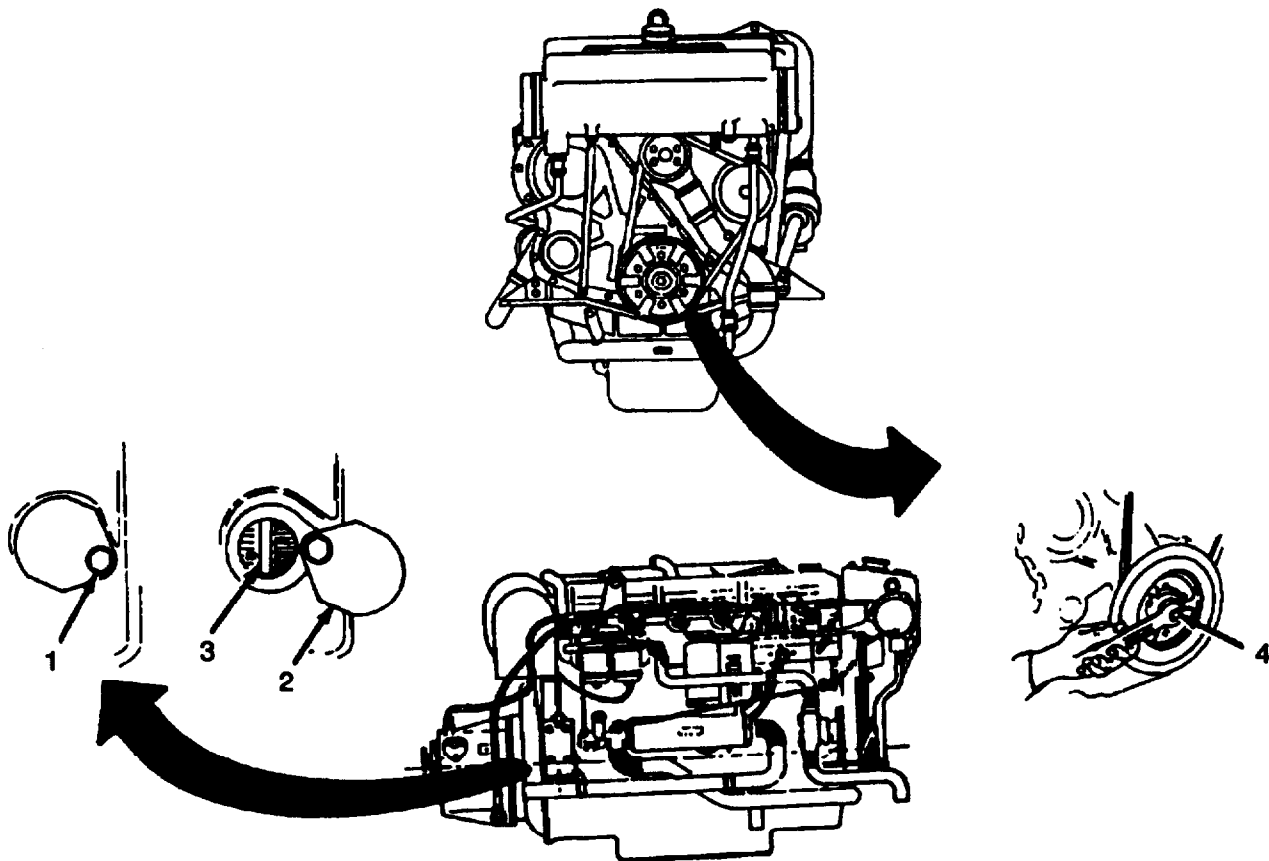

3. Using 1/2 inch wrench loosen bolt (1) securing inspection plate (2) and swing plate 1/2 turn clockwise to expose flywheel and ring gear (3). Wipe area using clean rag.
4. With one person in position using inspection mirror and flashlight and other person using 15/16 inch wrench on crankshaft pulley retaining bolt (4), turn starter ring gear one complete revolution counterclockwise (using a series of short moving motions) for inspection.
5. Inspect ring gear for cracks, broken or missing teeth. Inspect housing for cracks and loose nuts/bolts. Report any damage or defect to Direct Support Maintenance.
6. Complete inspection and close inspection plate (2). Secure plate by tightening bolt (1) with 1/2 inch wrench.

NOTE

For starboard flywheel and starter ring gear inspection only, reinstall buoyancy flotation material (refer to paragraph 3-152).

7. Close battery hatch.
8. Close engine hatches.

3-131. SUMP PUMP REPLACEMENT INSTRUCTIONS

TOOLS: 1/2 inch Socket
7/8 inch Open End Wrench
Ratchet

PARTS/MATERIALS: Engine Sump Pump

REMOVE:

1. Open and secure engine hatches (refer to paragraph 3-154).

NOTE

Replacement of the starboard sump pump requires removal of buoyancy flotation material from starboard side (refer to paragraph 3-152).

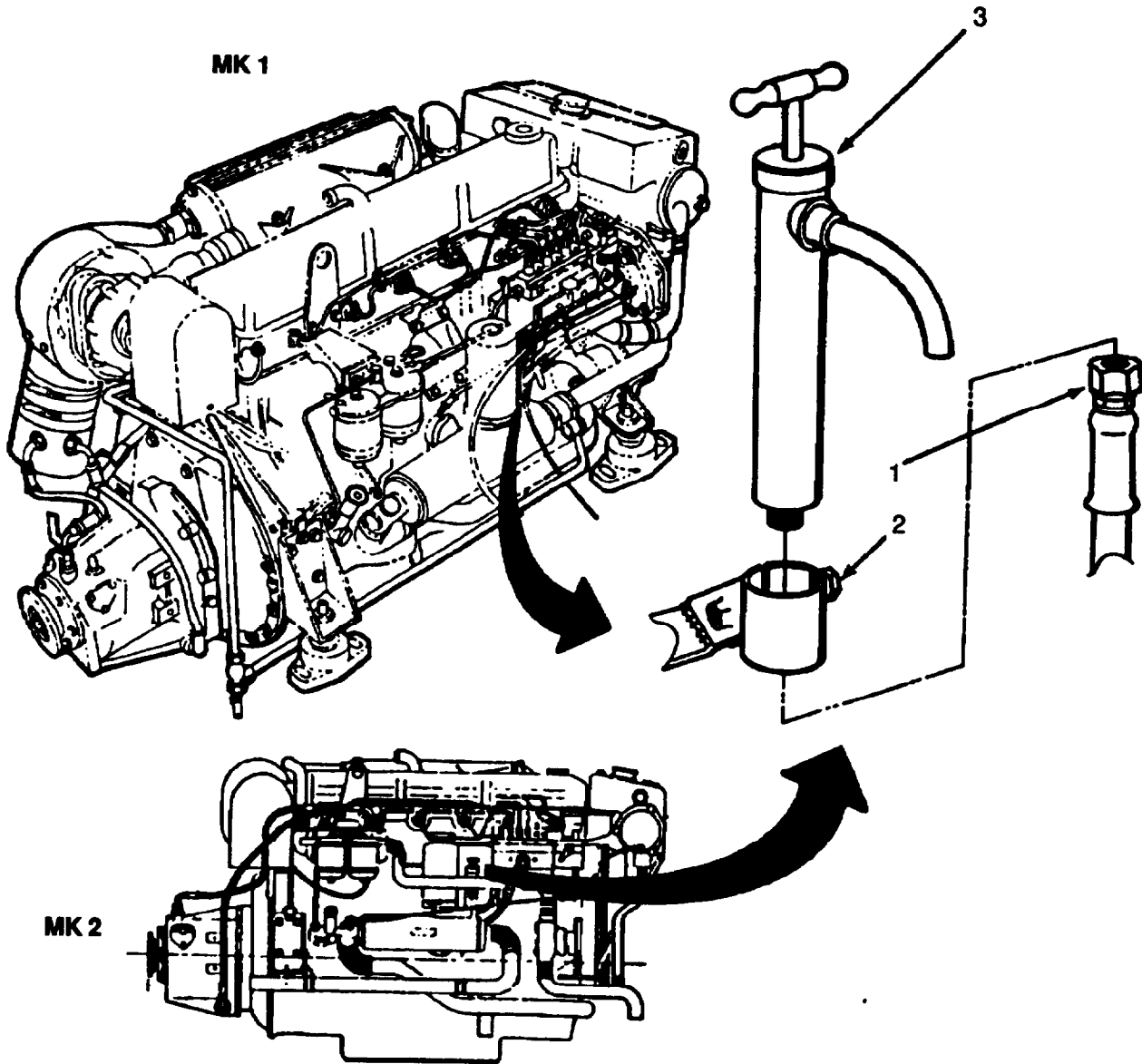

2. Using wrench disconnect oil pick-up line (1) from base of pump.
3. Loosen bolt (2) on sump pump bracket using socket.
4. Lift pump (3) out of bracket.

INSTALL:

1. Position pump (3) in bracket with spout pointing away from engine.
2. Connect oil pick-up line (1) to base of pump and position pump so no sharp bends are in oil line.
3. Using socket tighten bracket bolt (2) to secure pump.
4. Tighten oil pick-up line (1) to base of pump using wrench.
5. Wipe up oil with rag.

NOTE

For starboard sump pump replacement only, replace buoyancy flotation material (refer to paragraph 3-152).

6. Close engine hatches.

3-132. ENGINE BREATHER WATER TRAP ASSEMBLY REPLACEMENT INSTRUCTIONS

TOOLS: Flat Tip Screwdriver
13 mm Box Wrench
13 mm Socket
Ratchet

PARTS/MATERIALS: Engine Breather Water Trap Assembly

REMOVE:

1. Open and secure engine hatches (refer to paragraph 3-154).

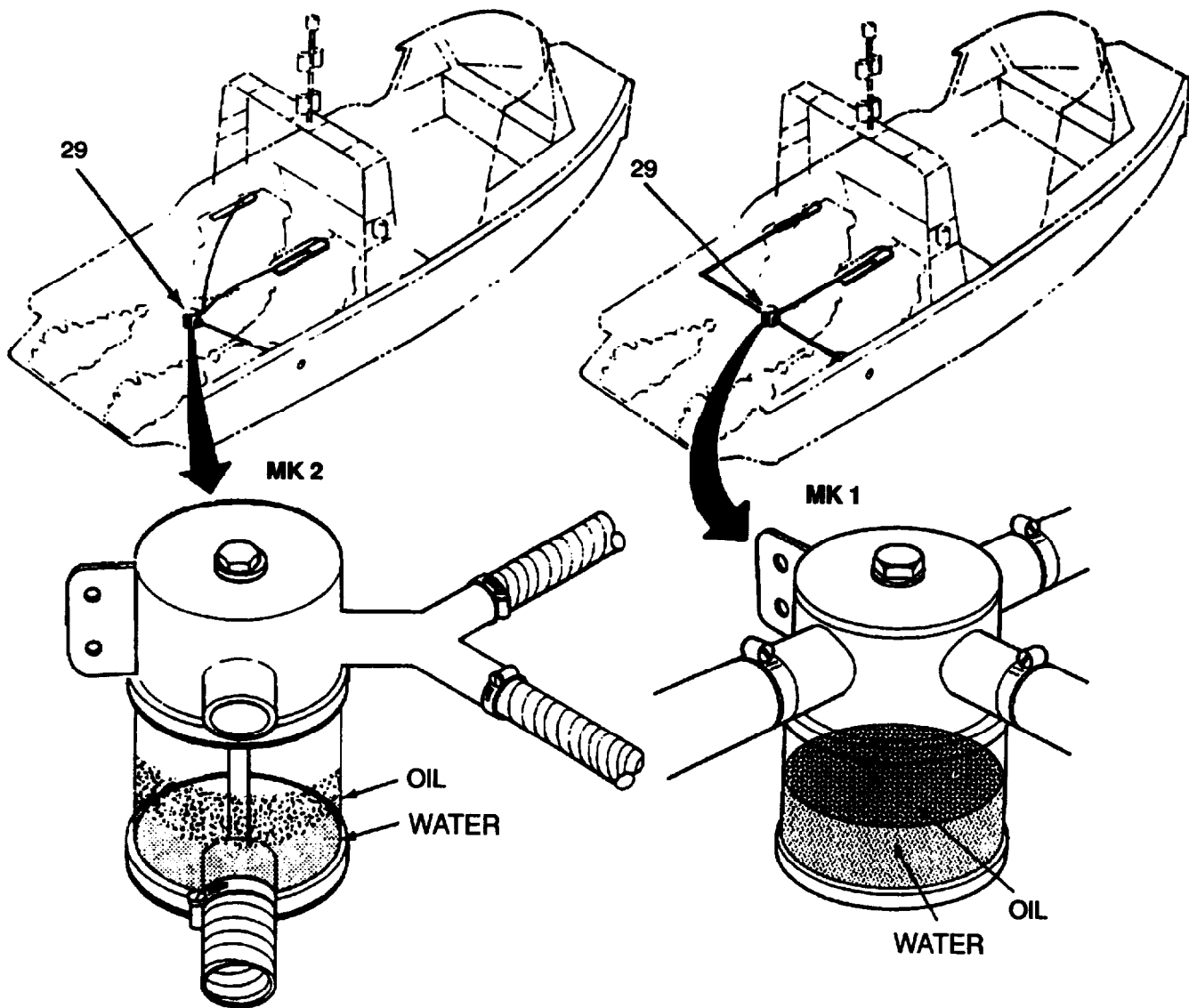

2. Using flat tip screwdriver loosen hose clamps (1).
3. Remove port engine hose (2), starboard engine hose (3) and vent hose (4) from trap assembly (5).
4. Using 13 mm socket and 13 mm box wrench remove bolts (6), flat washers (7) and nuts (8).
5. Remove trap assembly from bracket (9).

REPLACE:

1. Aline trap assembly with bracket (9).
2. Using 13 mm socket and 13 mm box wrench install bolts (6), flat washers (7) and nuts (8) securing trap assembly to bracket (9).
3. Attach port engine hose (2), starboard engine hose (3) and vent hose (4) to trap assembly (5).
4. Using flat tip screwdriver tighten hose clamps (1).
5. Close engine hatches.

3-133. AIR FILTER AND SILENCER SERVICE/REPAIR/REPLACEMENT INSTRUCTIONS

TOOLS: 5/16 inch Socket

7/16 inch Socket

Ratchet

Flat Tip Screwdriver, 4 inch

10 mm Combination Wrench

PARTS/MATERIALS: Air Filter Element

Silencer Elements

Hot Water and Detergent

Filter Materiel

REMOVE:

1. Open and secure engine hatches (refer to parapaph 3-154).

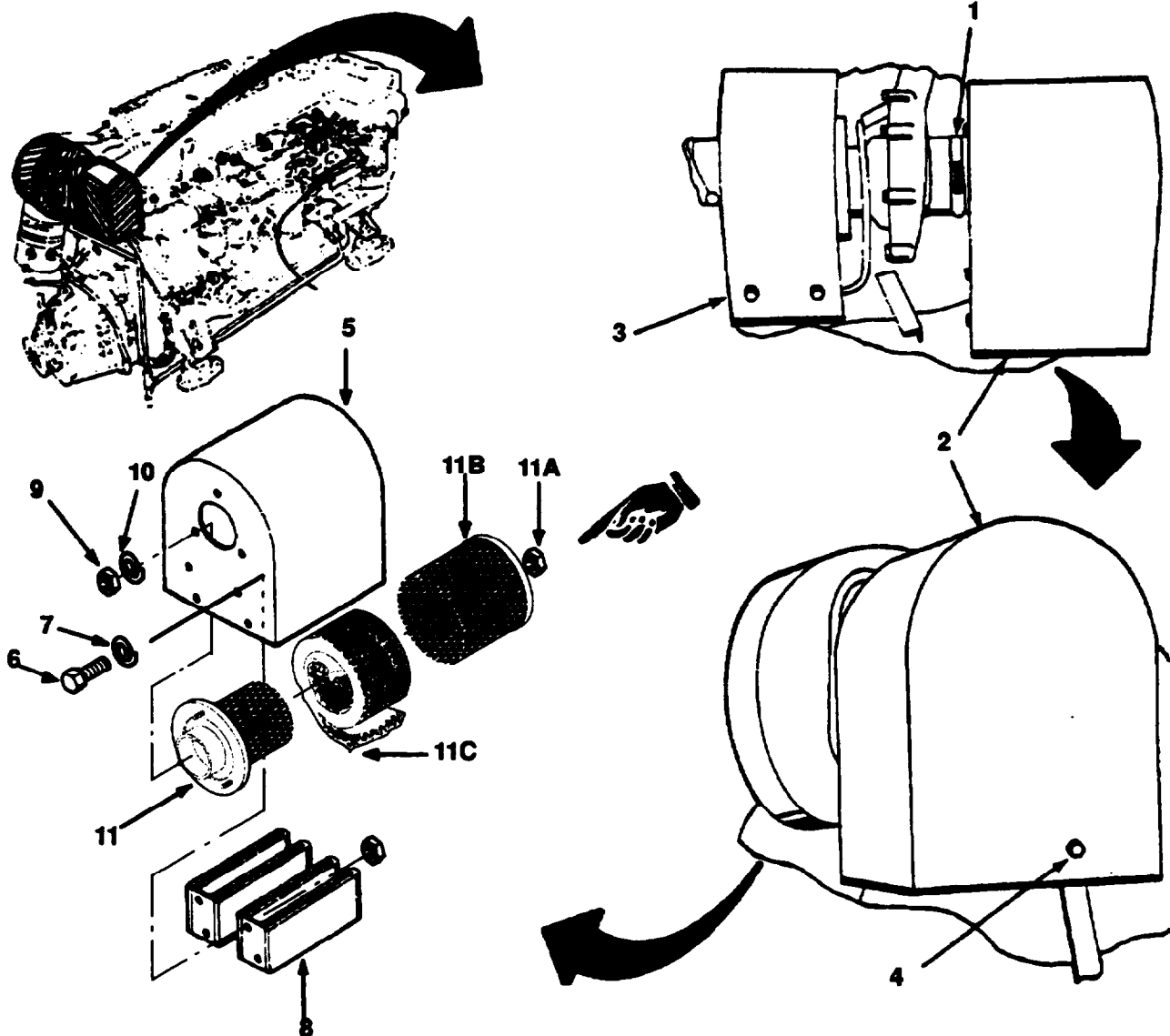

2. Using screwdriver loosen hose clamp (1) between air filter assembly (2) and turbocharger (3).
3. Using 5/16 inch socket remove one bolt (4) from filter cover (5) at mounting bracket.
4. Remove air filter assembly (2) from turbocharger (3).

DISASSEMBLE:

1. Using 5/16 inch socket remove bolts (6) and washers (7) securing silencers (8) to air filter cover (5).
2. Using 7/16 inch socket remove three nuts (9) and washers (10) securing air filter (11) to filter cover (5).
3. Discard silencer elements (8).
- 3.a. Inspect air filter (11) and air filter cover (5) for damage.
4. Immerse air filter (11) and air filter cover (5) in a solution of detergent and hot water.
5. Agitate assembly to remove dirt.
6. Repeat operation in fresh clear water until dirt is removed.
7. Rinse in fresh, clear water and allow to drip dry.

REPAIR:

1. Using 10 mm combination wrench remove nut (11A) from air filter element (11).
2. Remove cage (11B) from air filter element (11).
3. Remove filter materiel (11C) from air filter element (11).
4. Replace with new filter materiel (11C) 11 ft (3.35m) in length.
5. Install cage (11B) on air filter element (11).
6. Install nut (11A) using a 10 mm combination wrench.

ASSEMBLE:

1. Install air filter (11) and cover (5).
2. Install three washers (10) and nuts (9) and tighten using 7/16 inch socket.
3. Replace silencers (8) in lower portion of filter cover (5) and aline holes.
4. Install washers (7) and bolts (6) and tighten using 5/16 inch wrench.

INSTALL:

1. Reinstall air filter assembly (2) to turbocharger (3). Connect hose between air cleaner and turbocharger and tighten hose damp (1) using flat tip screwdriver.
2. Install bolt (4) thru filter assembly into cover mounting bracket.
3. Close engine hatches.

3-134. ENGINE OIL REPLACEMENT INSTRUCTIONS

TOOLS: None

PARTS/MATERIALS: Oil (New), 17 Quarts (16.4 Liters) OE/HDO 30 Oil (MIL-L-2104C)
Container, Five Gallon Capacity

NOTE

Oil should be changed when hot.

REMOVE:

1. Open and secure engine hatches (refer to paragraph 3-154).

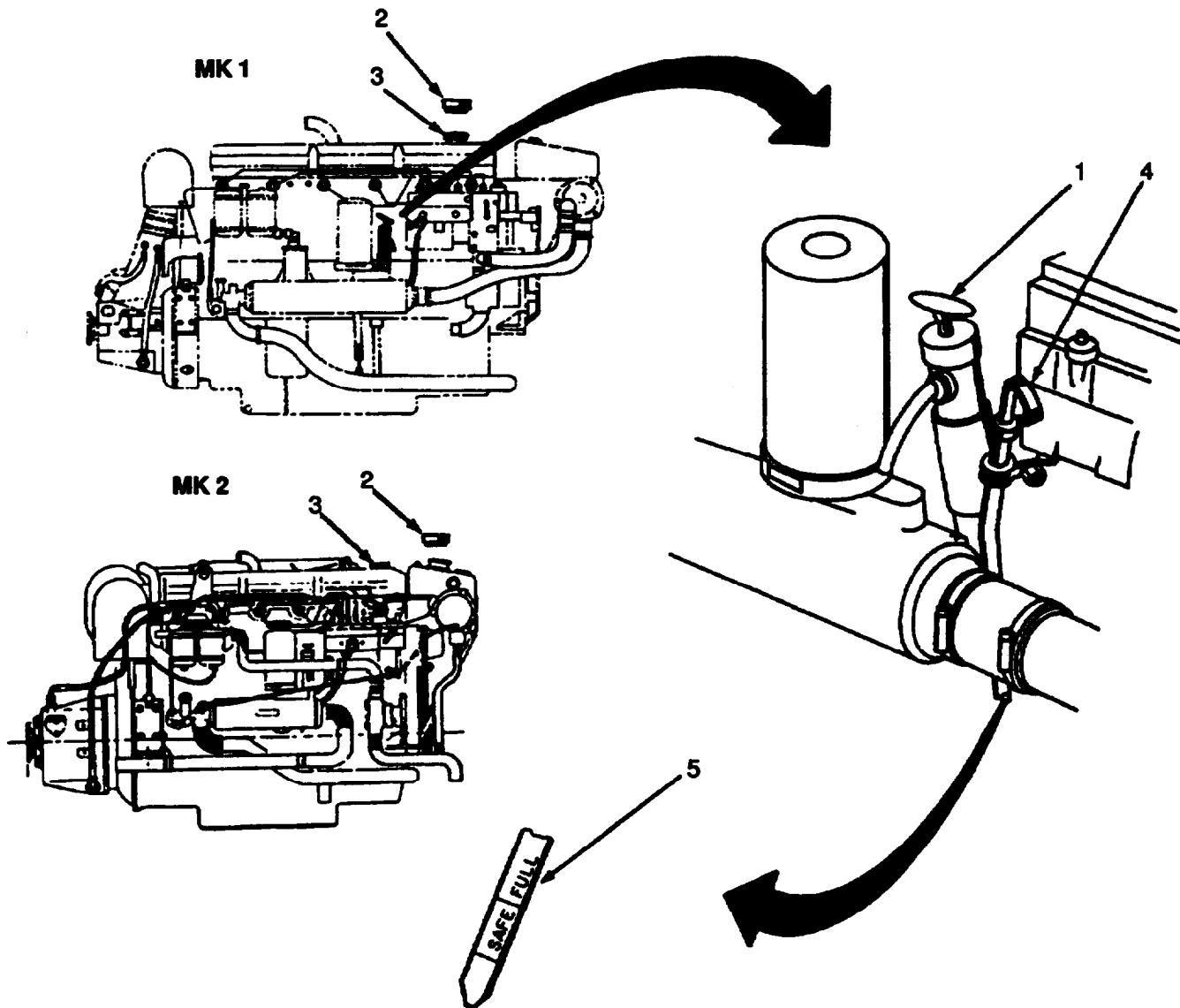

2. Using sump pump (1), pump used oil into five gallon container and discard.

INSTALL:

1. Remove oil filler cap (2). Add oil through oil filler (3) on rocker arm cover.

CAUTION

Do not overfill. Engine damage could result.

2. Check oil level on dipstick (4) and add oil until level reaches FULL mark (5).
3. Replace oil filler cap (2).
4. Close engine hatches.

3-135. TRANSMISSION OIL STRAINER INSPECTION, SERVICING AND REPLACEMENT INSTRUCTIONS

TOOLS: 7/8 inch Open End Wrench
3/4 inch Open End Wrench
1-1/16 inch Socket
Ratchet

PARTS/MATERIALS: Oil Strainer Assembly
Oil (New) (Refer to LO 5-1940-277-12/LI 1940-12)
Suitable Container
Rags

REMOVE:

1. Remove aft cockpit (refer to paragraph 3-27).
2. Open and secure engine hatches (refer to paragraph 3-154).

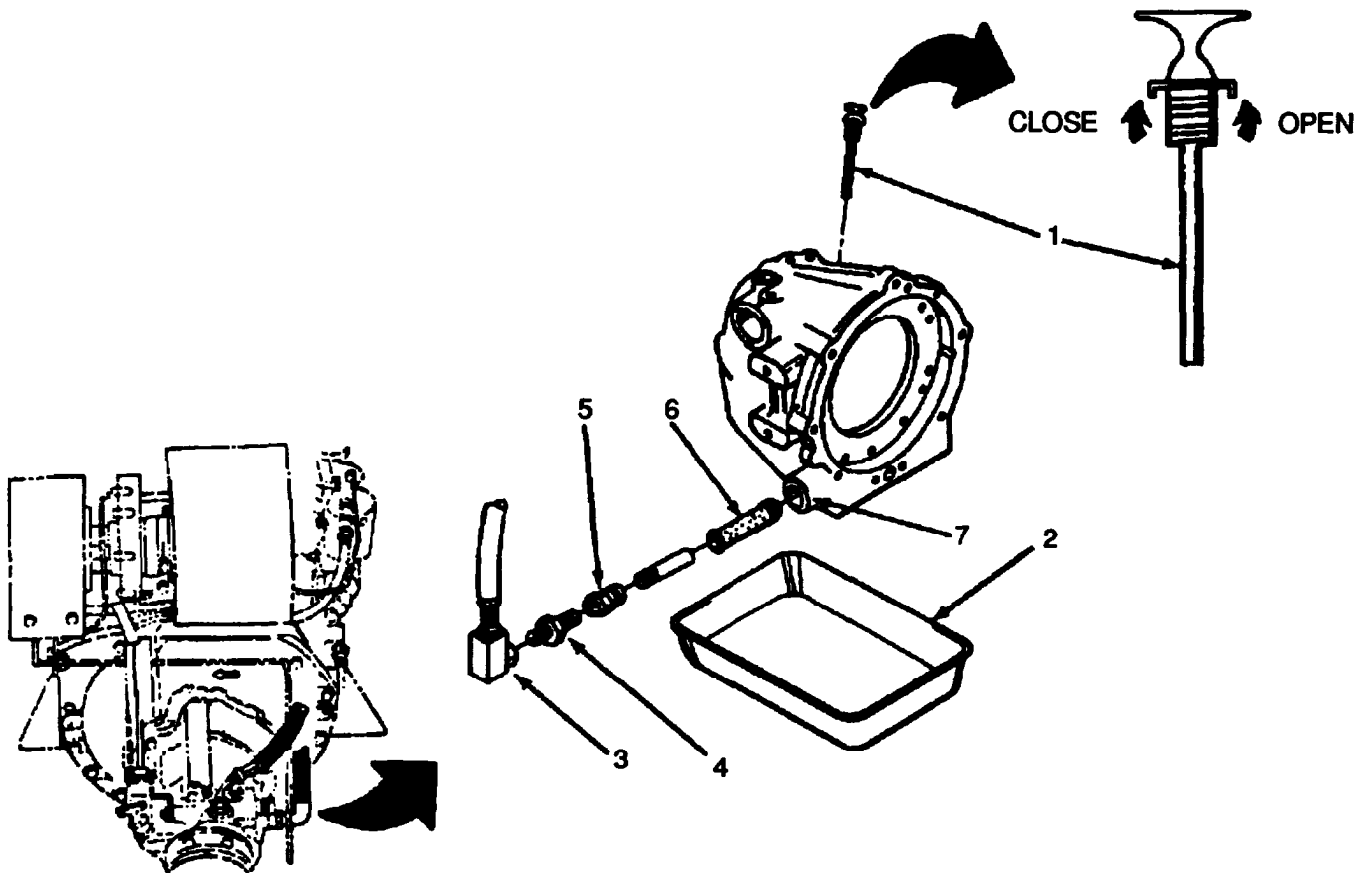

NOTE

Release expansion plug on dipstick assembly (1) by turning handle as shown in figure.
To seal, twist handle as shown in figure.

3. Remove oil filler cap and dipstick assembly (1).
4. Place container (2) under transmission.
5. Using 7/8 inch wrench remove oil return hose fitting (3).
6. Allow oil to drain into container (2).
7. Using 3/4 inch wrench remove adapter plug (4) from bushing (5).
8. Using 1-1/6 inch socket remove oil strainer assembly (9).
9. Remove oil strainer (6) from cooler return tube (8).
10. Remove oil cooler tube (8) from bushing (5).

CLEAN AND INSPECT:

1. Clean and inspect fittings, lines and adapter.
2. Clean strainer (6) thoroughly using cleaning solvent (Item 10, App. C).
3. Inspect strainer (6). If broken, discard; if not, keep for reuse.

INSTALL:

1. Wipe excess oil from drain (7) and remove drained oil collected in container (2).
2. Assemble oil strainer (6), cooler return tube (8) and bushing (5).
3. Slide assembly (6 and 5) into transmission oil drain hole (7) and tighten using 1-1/16 inch socket.
4. Insert adapter plug (4) into opening in return line bushing (5) and tighten using 3/4 inch wrench.
5. Attach oil return hose fitting (3) to adapter plug (4) and tighten using 7/8 inch wrench.
6. Fill transmission with new fluid (refer to LO 5-1940-277-12/LI 1940-12).
7. Insert oil filler cap and dipstick assembly (1).
8. Close engine hatches.
9. Replace aft cockpit.

3-136. TRANSMISSION OIL HOSES AND FITTINGS REPLACEMENT INSTRUCTIONS

TOOLS: 3/4 inch Open End Wrench
7/8 inch Open End Wrench

PARTS/MATERIALS: Oil Feed Hose Assembly
Oil Return Hose Assembly
Adapters
Seals
Bushings
Suitable Container
Oil (New) (Refer to LO 5-1940-277-12/LI 1940-12)
Oil Cooler Return Tube
Oil Strainer
Rags

REMOVE:

1. Remove aft cockpit (refer to paragraph 3-27).
2. Open and secure engine hatches (refer to paragraph 3-154).

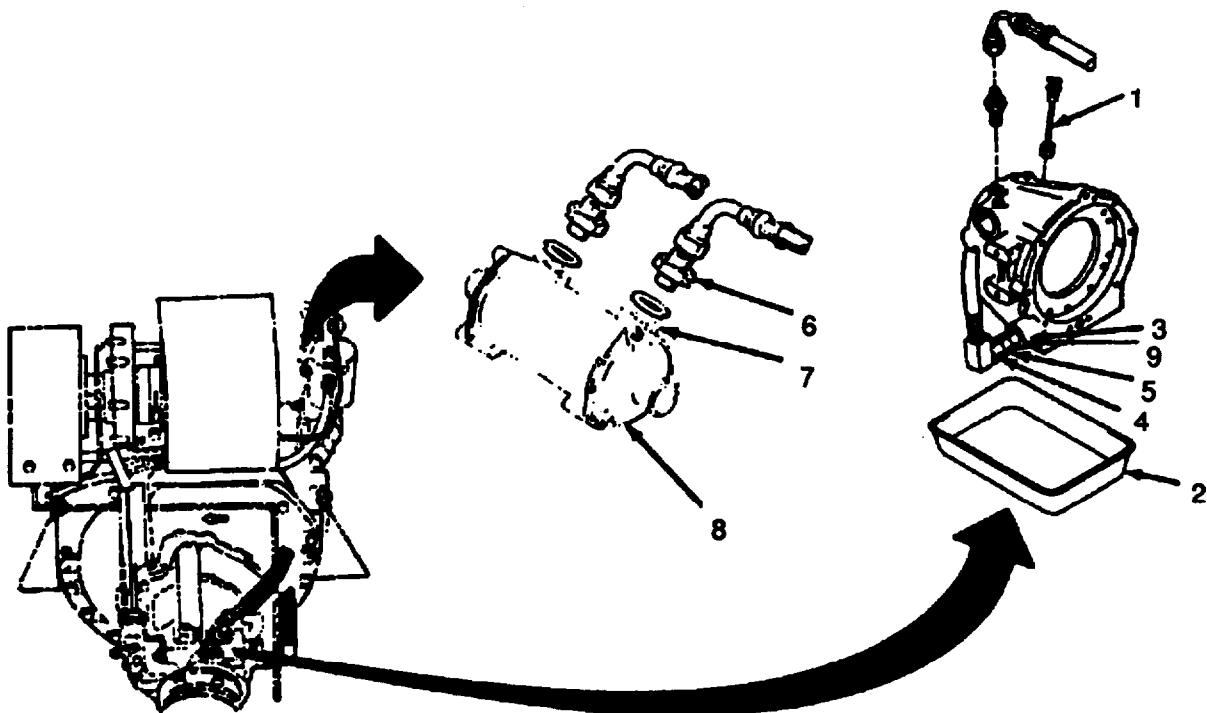

TRANSMISSION OIL RETURN HOSE AND FITTINGS:

REMOVE:

1. Remove oil filler cap and dipstick assembly (1).
2. Place suitable container (2) under drain (3).
3. Using 7/8 inch open end wrench remove oil return hose fitting (4).
4. Allow oil to drain.
5. Using 3/4 inch open end wrench remove adapter (5).
6. Using 7/8 inch open end wrench remove hose fitting (8) from adapter (7) on transmission oil cooler (8).

CLEAN AND INSPECT:

1. Clean and inspect bushings, hoses and hose fittings:
 - a. Replace bushings and return tube (8) if corroded, split, bent or damaged.
 - b. Replace hoses if split, cracked, cut, spongy or damaged.
2. Discard damaged items.

INSTALL:

1. Using 7/8 inch open end wrench install hose fitting (6) onto adapter (7).
2. Using a rag (Item 4, App. C) wipe excess oil from drain hole (3).
3. Using 3/4 inch box wrench insert and tighten adapter (5) into bushing (9).
4. Attach oil return hose fitting (4) to adapter (5).
5. Using 7/8 inch open end wrench tighten fitting (4).

NOTE

If oil returned hose replacement is the only procedure to be performed, service with oil (refer to LO 5-1940-277-12/LI 1940-12) and close hatches.

TRANSMISSION OIL FEED HOSE

REMOVE:

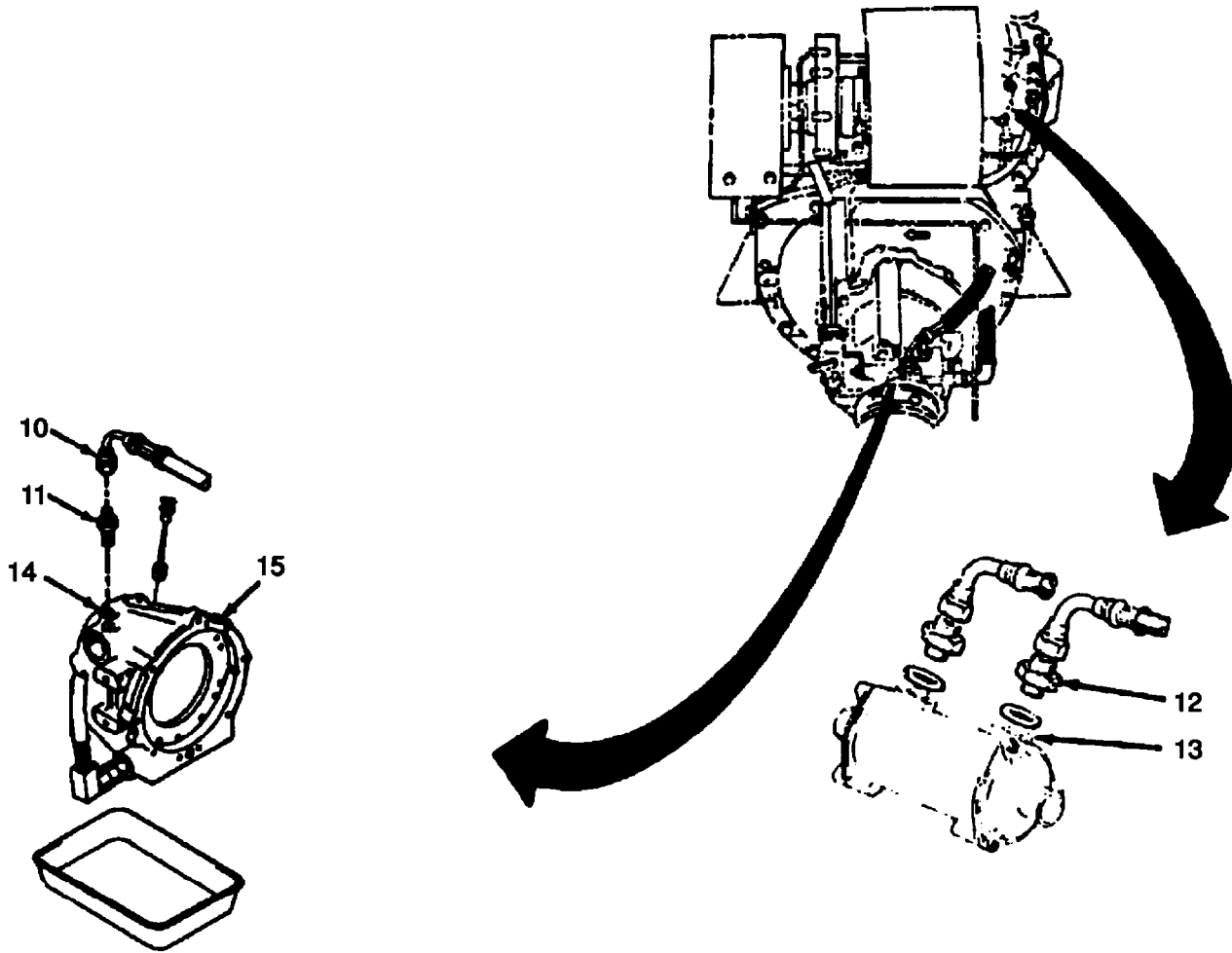

1. Using 7/8 inch open end wrench remove oil feed hose fitting (10).
2. Using 3/4 inch box wrench remove adapter plug (11).
3. Using 7/8 inch open end wrench remove hose fitting (12) from adapter (13).

INSPECT:

1. Inspect hose and hose fittings:
 - a. Replace hose if split, cracked, cut, spongy or damaged.
 - b. Replace fittings if bent, cracked, corroded or damaged.
2. Discard damaged items.

INSTALL:

1. Using 7/8 inch open end wrench install hose fitting (12) onto adapter (13).
2. Insert adapter plug (11) into hole (14) on transmission (15).
3. Using 3/4 inch box wrench tighten adapter plug (11).
4. Attach oil feed hose fitting (10) to adapter plug (11).
5. Using 7/8 inch open end wrench tighten hose fitting (10).
6. Service transmission (refer to LO 5-1940-277-12/LI 1940-12).
7. Reinstall aft cockpit (refer to paragraph 3-27).
8. Close engine hatches.

3-137. TRANSMISSION INSPECTION INSTRUCTIONS

TOOLS: None

PARTS/MATERIALS: None

INSPECT:

1. Remove aft cockpit (refer to paragraph 3-27).
2. Open and secure engine hatches (refer to paragraph 3-154).

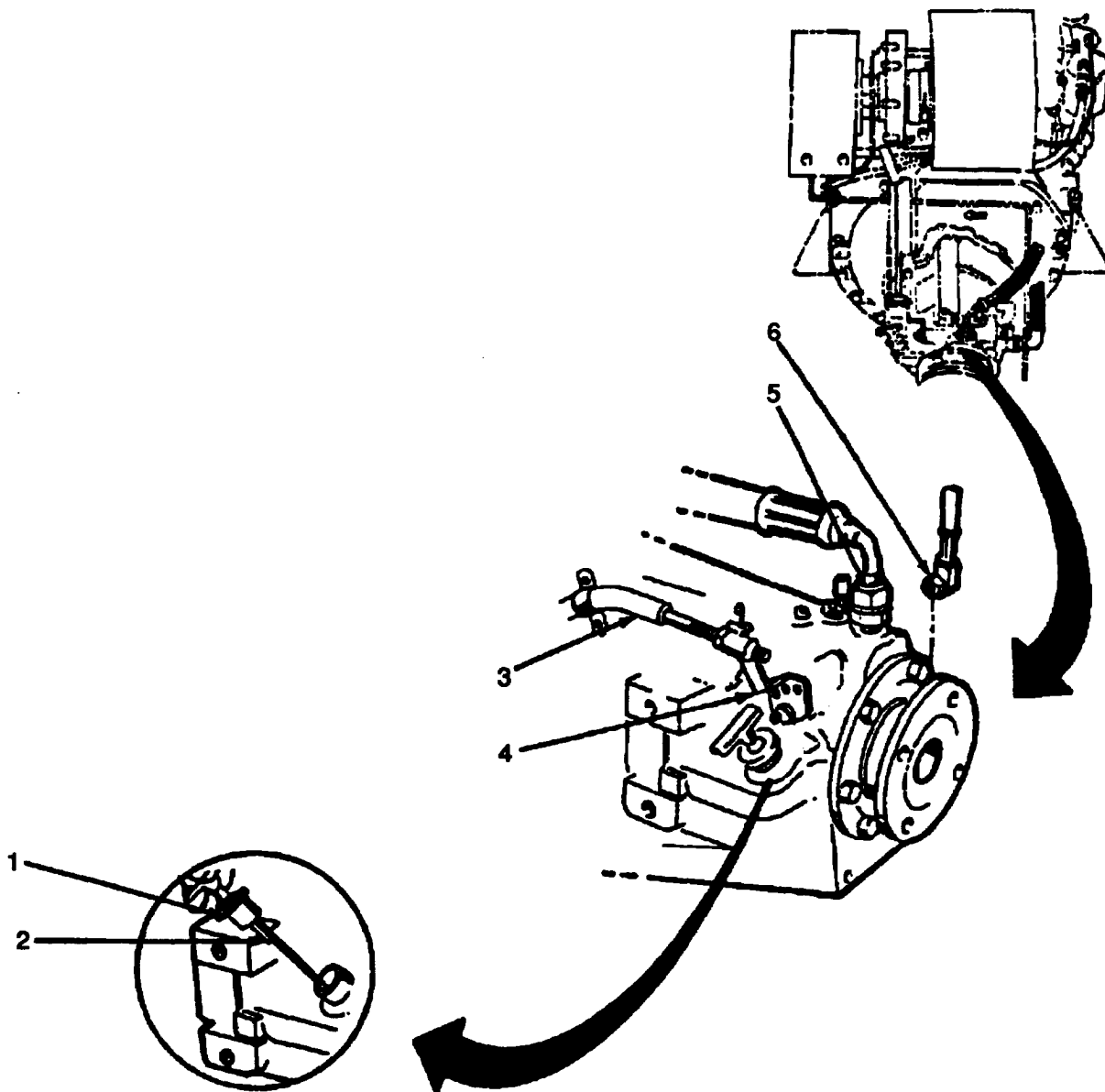

3. Check dipstick filler expansion plus (1) for proper fit and condition. Replace if split, cut or cracked.
4. Check dipstick (2) for legibility.
5. Check transmission control cable (3). Linkage between control cable and transmission control lever (4) must be tight.
6. Check oil feed assembly (hoses and fittings) (5) for damage or wear. (To replace, refer to paragraph 3-67).
7. Check oil return assembly (hoses and fittings) (6) for damage or wear. (To replace, refer to paragraph 3-67).
8. Close engine hatches.
9. Replace aft cockpit (refer to paragraph 3-27).

3-138. STEERING ASSEMBLY BRUSH REPLACEMENT INSTRUCTIONS

TOOLS: 13 mm Box Wrench
13 mm Open End Wrench

PARTS/MATERIALS: Brush

PERSONNEL REQUIRED: Two

REMOVE:

NOTE

Boat must be out of water to perform this task.

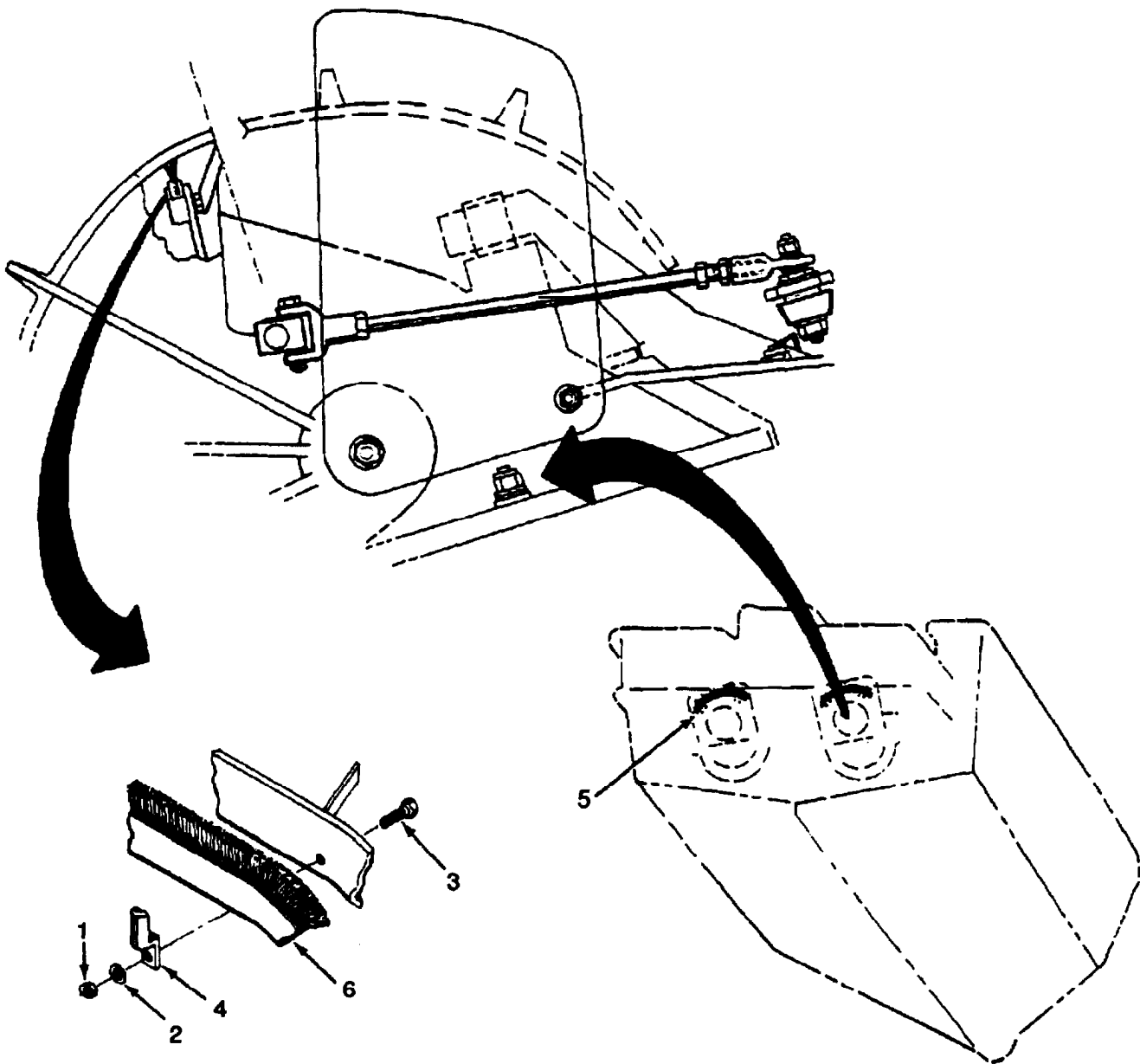

1. Scoop controls in full reverse position.
2. Using two wrenches loosen four nuts (1), washers (2) and bolts (3) on damp (4) located on waterjet nozzle (5).
3. Slip brush (6) out of clamp and discard.

INSTALL:

1. Position replacement brush (6) in clamps (4).

NOTE

Bristles on brush point away from jet nozzle opening. Centralize brush in clamps so that equal lengths of brush run down each side of jet nozzle.

2. Reinstall four bolts (3), washers (2) and nuts (1) on clamp (4) using two wrenches.

3-139. HYDROJET TAIL CONE ANODES REPLACEMENT INSTRUCTIONS

TOOLS: 19 mm Socket
Ratchet
6 inch Extension
10 inch Extension

PARTS/MATERIALS: Tail Cone Anode
Degreasing Solvent (Item 10, Appendix C)
Steel Wool (Item 15, Appendix C)
Soap and Water Solution (Item 5, Appendix C)

REMOVE:

NOTE

- **The boat must be out of water on cradle or hardstand to perform this service.**
- **Access to the hydrojet tail cone anodes is through the aft end of the hydrojet unit.**

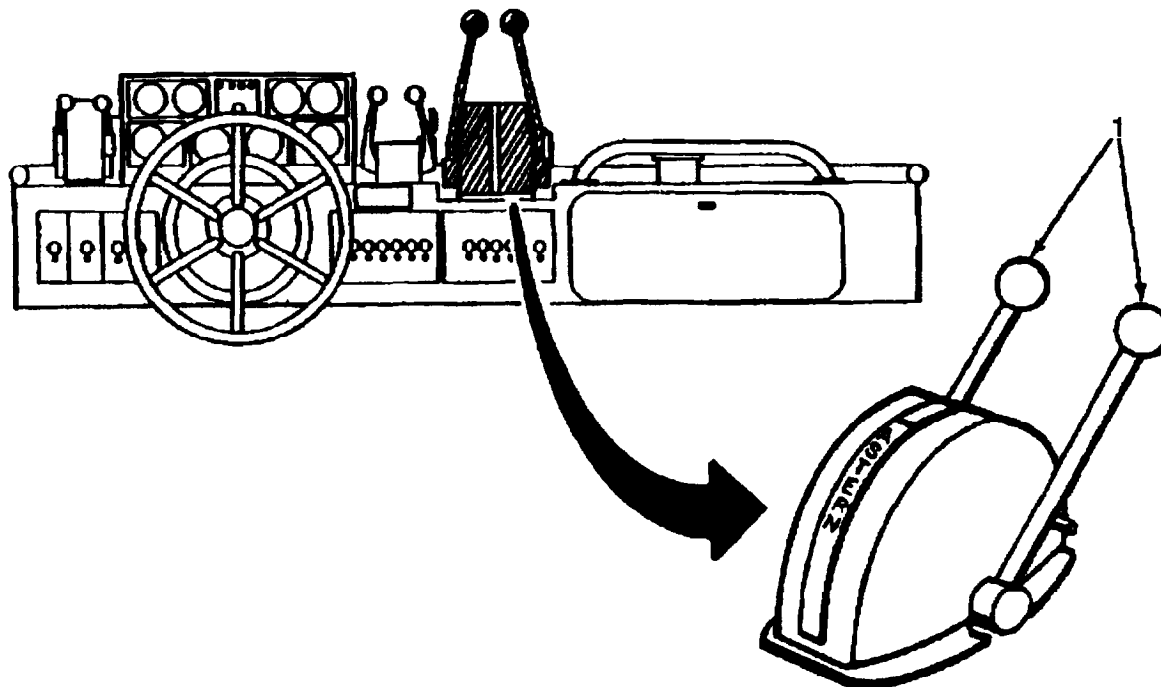

1. Move scoop control levers (1) to FULL FORWARD position.

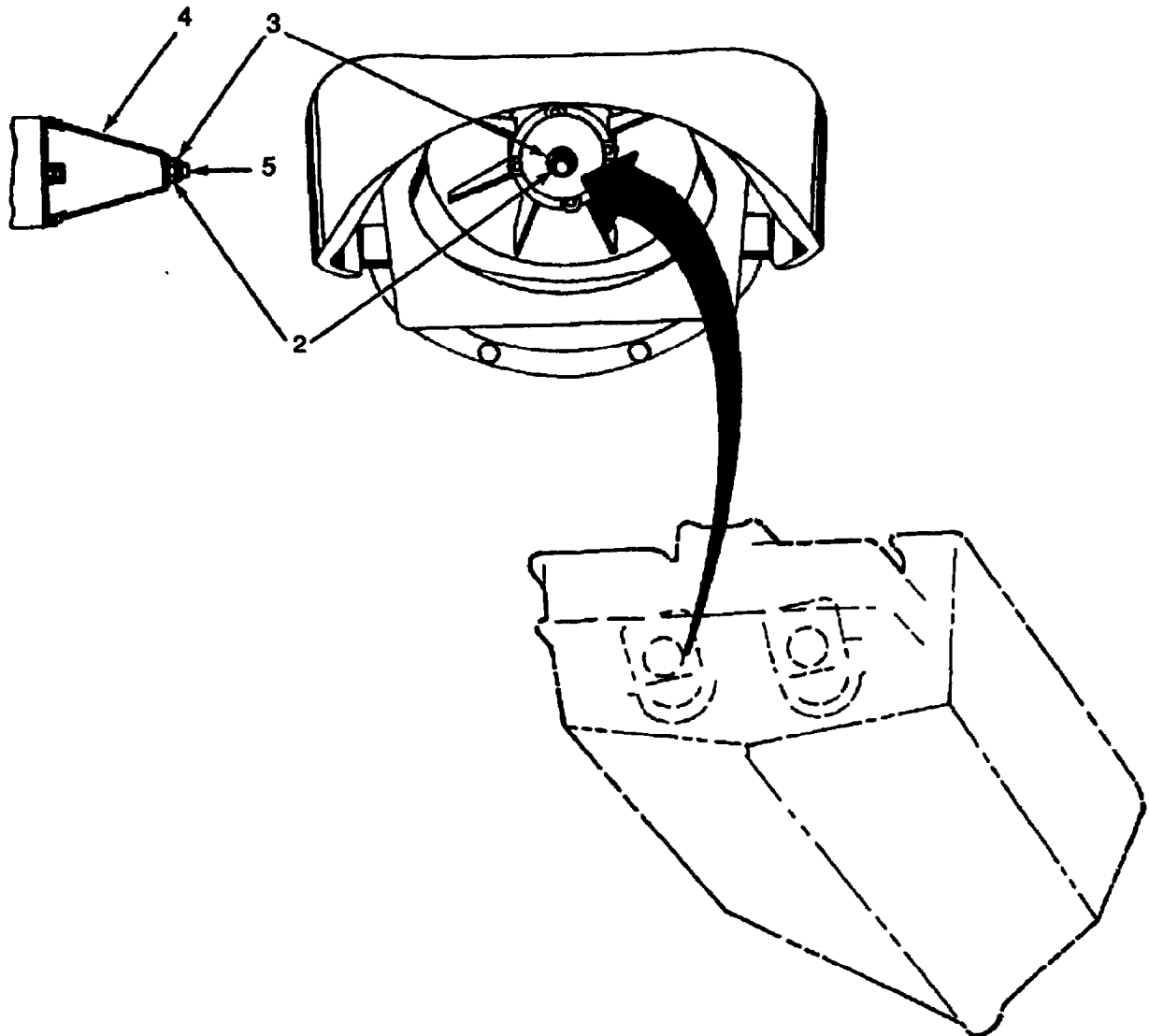

2. Using socket with 10 inch and 6 inch extensions, remove nut (2) and washer (3) securing anode (4) to shaft (5).
3. Remove anode (4) from mounting shaft (5) and discard.
4. Thoroughly clean anode mounting shaft and tail cone mating surfaces with degreasing solvent and steel wool. Wash with soap and water solution and dry.

INSTALL:

1. Position replacement anode (4) on tail cone shaft (5).
2. Using socket with 10 inch and 6 inch extensions install washer (3) and nut (2) and tighten using socket.

3-140. OIL RESERVOIR REPAIR INSTRUCTIONS

TOOLS: 8 mm Wrench Open End
Flat Tip Screw Driver

PARTS/MATERIALS: Oil Reservoir Pipe Extension, Clamp Hose

REMOVE:

1. Open and secure hydrojet hatch.
2. Drain oil reserve.
3. Using flat tip screwdriver remove clamps (1) and hose (2).
4. Using 8 mm open end wrench remove nut (3) and oil reservoir (4) from bracket (5).

INSTALL:

1. Position oil reservoir (4) on bracket (5).
2. Using 8 mm open end wrench reinstall nut (3).
3. Reinstall hose (2) with clamp (1).
4. Replenish oil in reservoir. Refer to LO 5-1940-277-12, LI 1940-12.

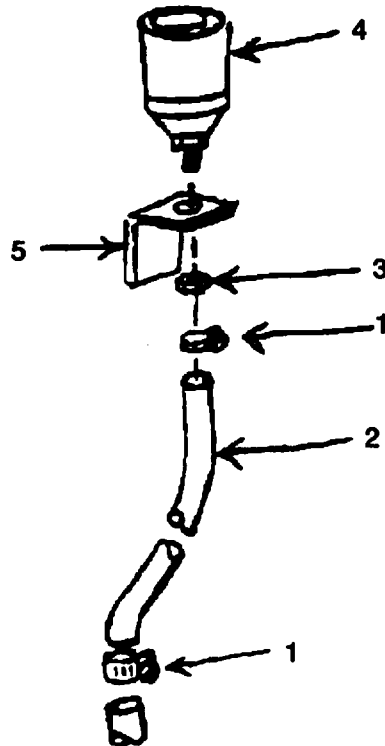

3-141. DRIVE SHAFT REPLACEMENT INSTRUCTIONS

TOOLS: Two 5/6 inch Open End Wrenches
Two 10 mm Box Wrenches

PARTS/MATERIALS: Drive Shaft Assembly

REMOVE:

1. Remove aft cockpit (refer to paragraph 3-27).

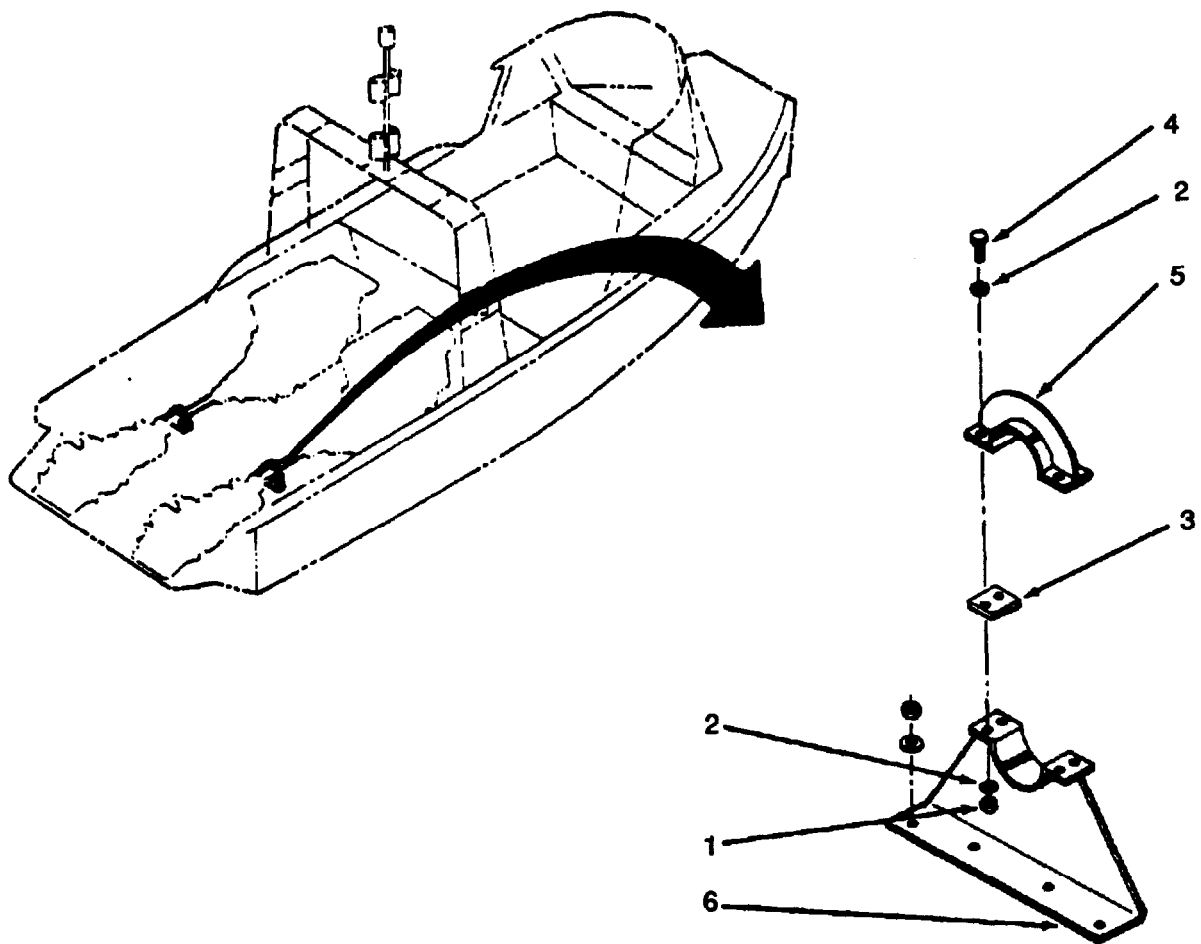

2. Using two 10 mm box wrenches remove four nuts (1), washers (2), spacers (3) and bolts (4) securing drive shaft collar (5) to support (6).
3. Remove spacer (3) and collar (5).

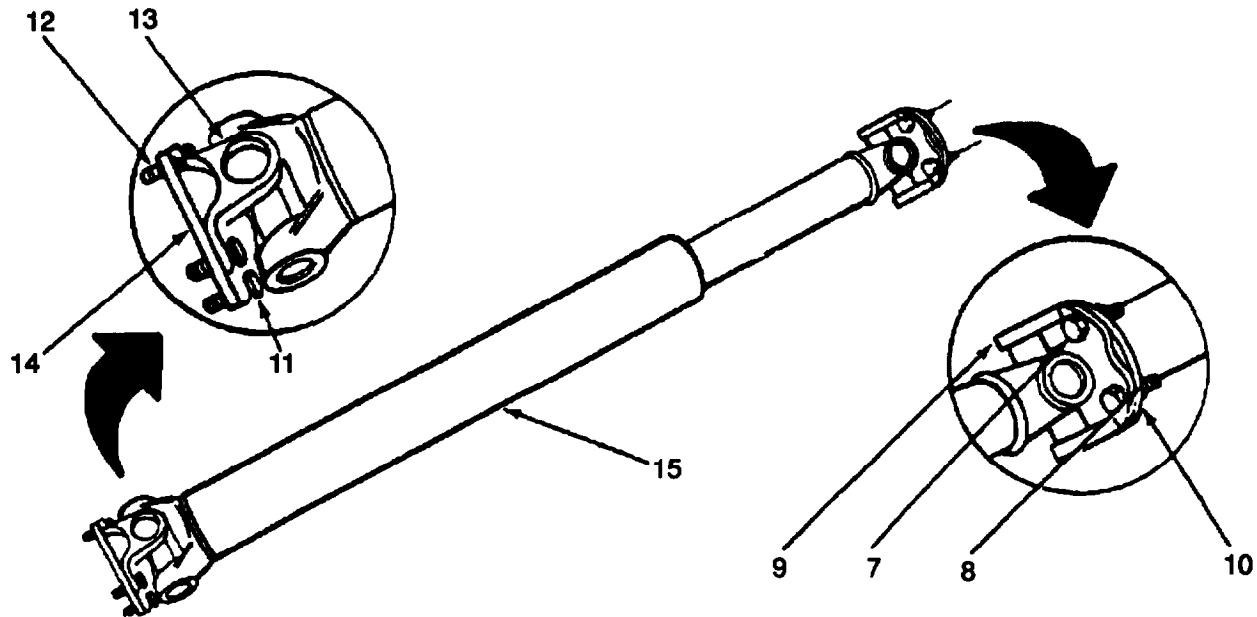

4. Using two 5/8 inch open end wrenches remove four bolts (7) and lock nuts (8) securing drive shaft coupling (9) to transmission flange (10).
5. Using two 5/8 inch open end wrenches remove four bolts (11) and lock nuts (12) securing drive shaft coupling (13) to hydrojet flange (14).
6. Remove drive shaft (15) with end couplings (9 and 13).

INSTALL:

1. Replace drive shaft.
2. Using two 5/8 inch open end wrenches reinstall four bolts (7) and lock nuts (8) securing drive shaft coupling (13) to transmission flange (10).
3. Using two 5/8 inch open end wrenches reinstall four bolts (11) and lock nuts (12) securing drive shaft to hydrojet flange (14).
4. Reinstall spacers (3) and collar (5).
5. Using two 10 mm box wrenches reinstall four bolts (4), washers (2) and nuts (1) securing drive shaft collar to support.
6. Reinstall aft cockpit (refer to paragraph 3-27).

3-142. DRIVE SHAFT ASSEMBLY REPAIR INSTRUCTIONS

TOOLS: Press
Snap Ring Pliers

PARTS/MATERIALS: Universal Joint

REMOVE:

1. Remove aft cockpit (refer to paragraph 3-27).
2. Remove drive shaft (refer to paragraph 3-141).

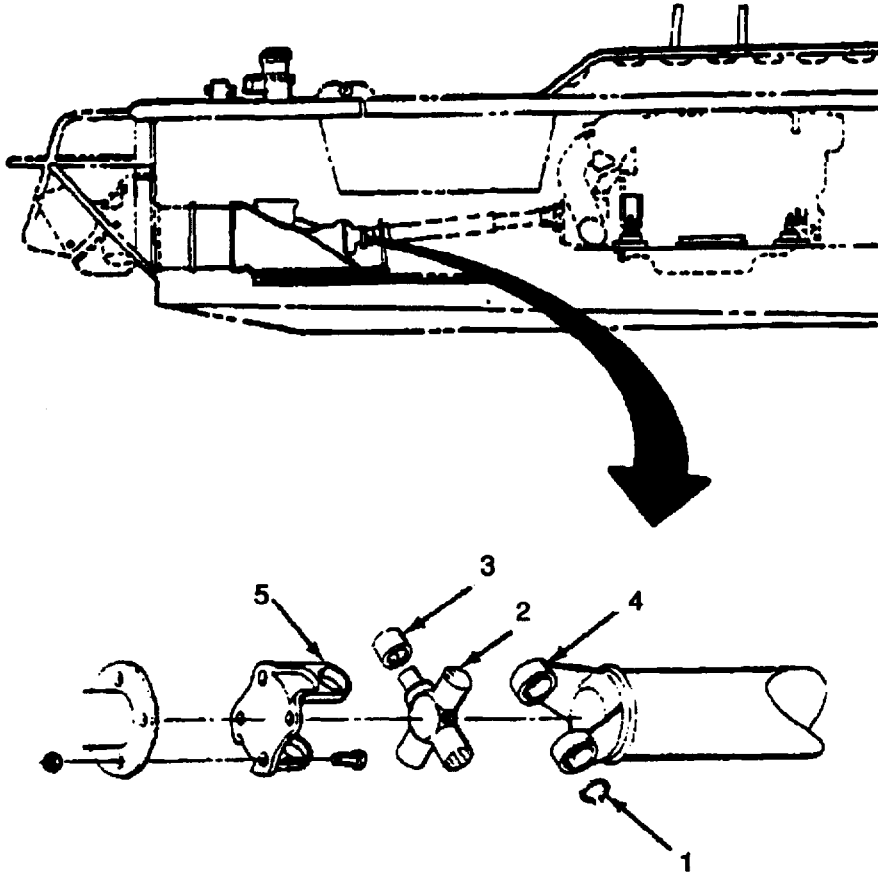

3. Using pliers remove four snap rings (1) securing universal joint (2) to yoke (4).
4. Using press remove universal joint spider (2) and cap (3) from yoke (4).
5. Using press remove universal joint spider (2) and cap (3) from flange yoke (5).

INSTALL:

1. Replace universal joint.
2. Using press install new universal joint spider (2) and cap (3) in yoke (4).
3. Using press install new universal joint spider (2) and cap (3) in flange yoke (5).
4. Using pliers reinstall four snap rings (1) securing universal joint (2) to yoke (4) and flange yoke (5).
5. Replace drive shaft (refer to paragraph 3-141).
6. Replace aft cockpit (refer to paragraph 3-27).

3-143. ELECTRIC BILGE PUMPS REPLACEMENT INSTRUCTIONS

TOOLS: Flat Tip Screwdriver
Two 13 mm Box Wrenches

PARTS/MATERIALS: Replacement Bilge Pumps

NOTE

This procedure applies to the aft and forward bilge pumps for the MK1 and the aft bilge pump for the MK2

REMOVE:

1. Open and secure hydrojet hatch covers (refer to paragraph 3-154).
2. Open and secure engine hatches (refer to paragraph 3-154).

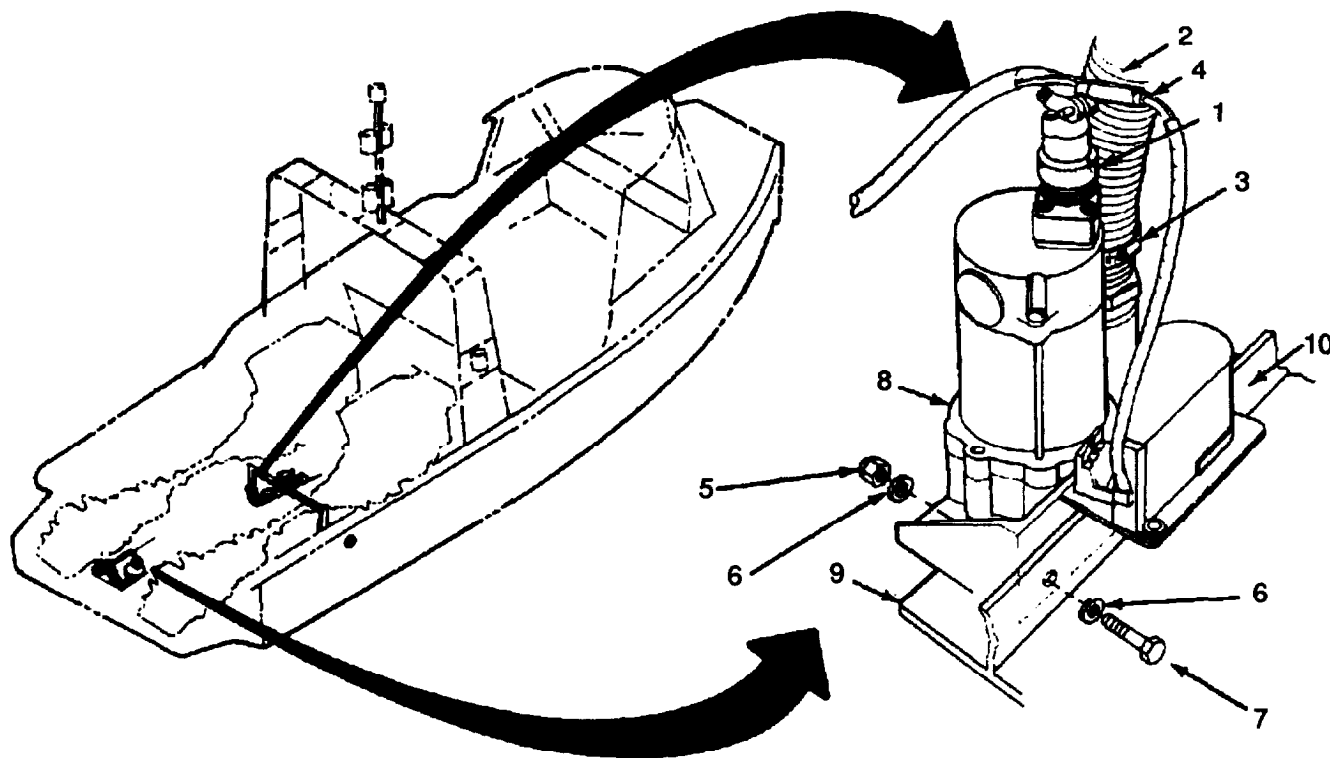

3. Unscrew and disconnect bilge pump motor electrical plug (1).
4. Disconnect sending unit lead (4).
5. Loosen bilge discharge hose clamp (3) with screwdriver and remove bilge discharge hose (2) from pump.
6. Using two wrenches remove two nuts (5), four washers (6) and two bolts (7) from pump base.
7. Remove pump assembly (8), bracket (9) and float switch (10) from boat as a unit.

- Using screwdriver remove four screws (11) and washers (12) from bracket (9) and pump assembly (8).
- Remove and clean screen (13).

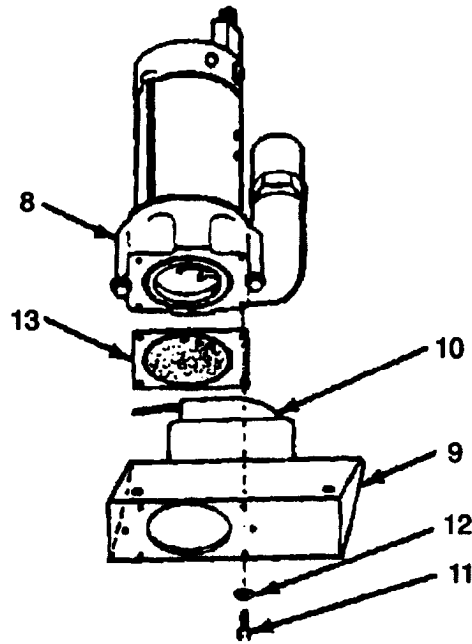

INSTALL:

- Fit pump assembly (8) to screen (13) and bracket (9). Insure screw holes are alined.
- Using screwdriver reinstall four screws (11) securing replacement bilge pump to bracket (9).
- Position replacement bilge pump in sump location.
- Aline holes of pump base with holes in mounting bracket on boat.
- Secure pump with two washers (6), mounting bolts (7) and nuts (5).
- Tighten two nuts (5) using wrench.
- Connect bilge discharge hose (2) to pump and tighten hose clamp (3) with screwdriver.
- Connect sending unit lead (4).
- Connect and screw on motor electrical plug (1).
- Close hydrojet hatch covers.
- Close engine hatch covers.

3-144. FORWARD ELECTRIC BILGE PUMP REPLACEMENT INSTRUCTIONS (MK2 ONLY)

TOOLS: Flat Tip Screwdriver

One 7/16 inch Socket Wrench with Extension

One 1/4 inch Box Wrench

PARTS/MATERIALS: Replacement Bilge Pump

REMOVE:

1. Open and secure hydrojet hatch covers (refer to paragraph 3-154).
2. Remove Aft Cockpit (refer to paragraph 3-27).
3. Open and secure engine hatches (refer to paragraph 3-154).

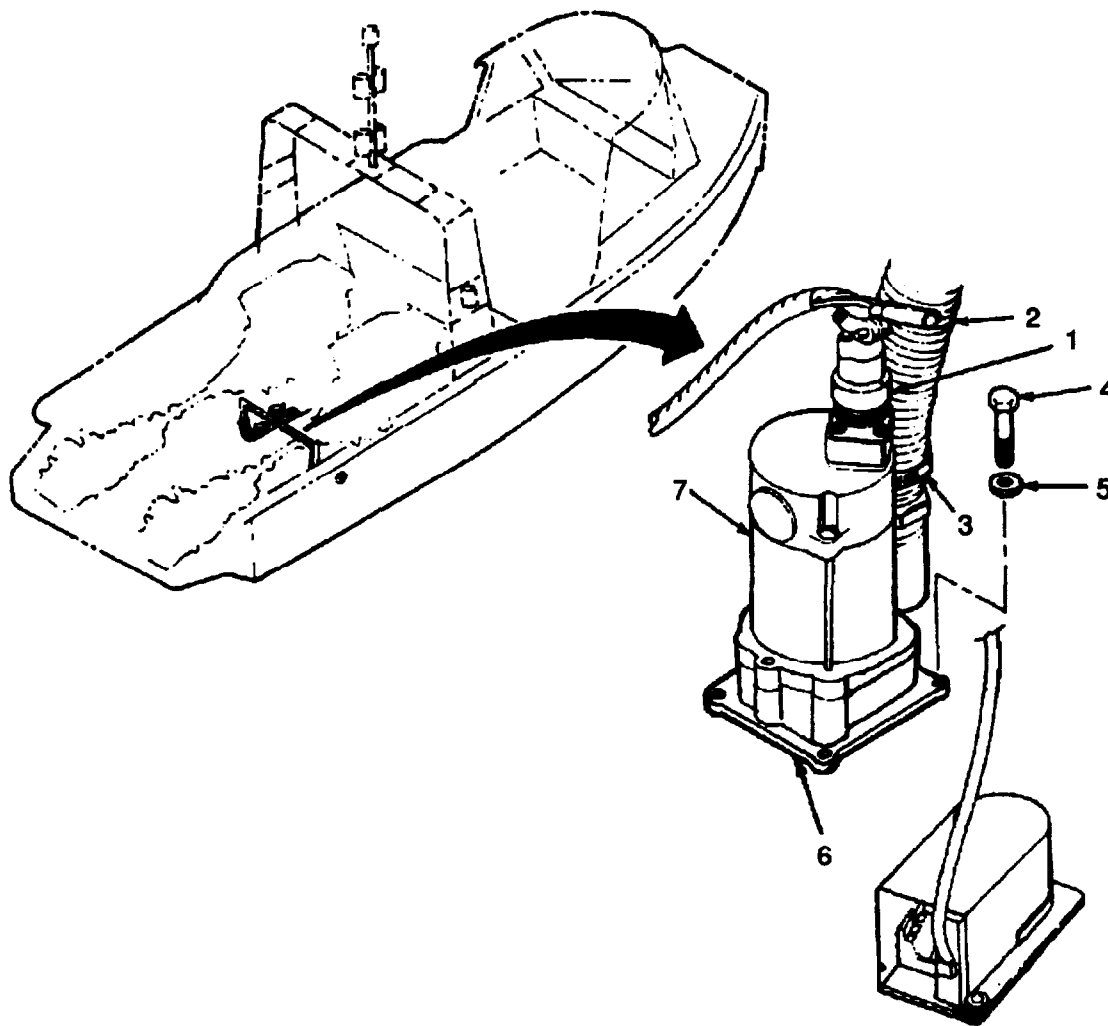

4. Unscrew and disconnect bilge pump motor electrical plug (1).
5. Loosen bilge discharge hose clamp (3) with screwdriver and remove bilge discharge hose (2) from pump.

6. Using 7/16 inch socket wrench remove three hex head screws, (4) and three washers (5) securing support plate (6).
7. Remove pump assembly (7) and support plate (6) from boat as a unit.
8. Using 1/4 inch wrench, remove four screws (8), four washers (9) and support plate (6) from pump assembly (7).
9. Remove and clean screen (10).

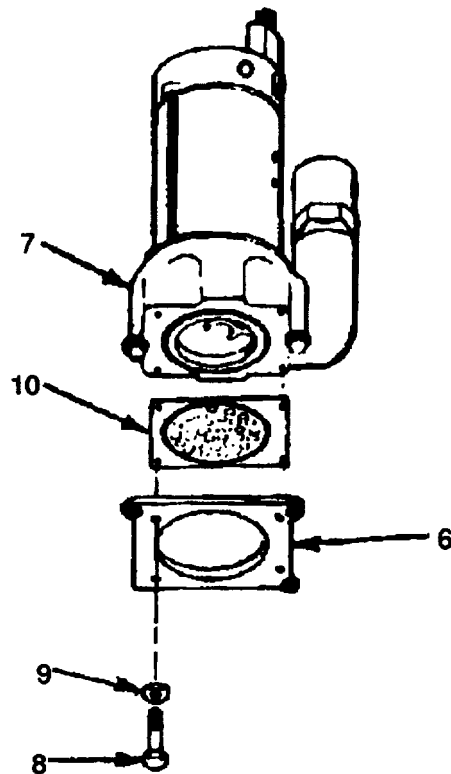

INSTALL:

1. Aline pump assembly (7) to screen (10) and support plate (6). Insure screw holes are alined.
2. Using 1/4 inch wrench reinstall four screws (8) and four washers (9) securing replacement bilge pump to support plate (6).
3. Position replacement bilge pump in sump location.
4. Aline holes of support plate with holes in mounting bracket on boat.
5. Secure support plate (6) and pump assembly (7) with three hex head screws (4) and three washers (5).
6. Using 7/16 inch socket wrench, tighten three screws (4).
7. Connect bilge discharge hose (2) to pump and tighten hose clamp (3) with screwdriver.
8. Connect and screw on motor electrical plug (1).
9. Close engine hatch covers (refer to paragraph 3-154).
10. Install aft cockpit (refer to paragraph 3-27).
11. Close hydrojet hatch covers (refer to paragraph 3-154).

3-145. ELECTRIC BILGE PUMP ASSEMBLY REPAIR INSTRUCTIONS

TOOLS: Two Flat Tip Screwdriver
7/16 inch Box Wrench
Impeller Nut Removal Tool (Item D-1, Appendix D)
(Manufactured locally)

PARTS/MATERIALS: Brushes
Bilge Pump Screen
Plastic Impeller
Gasket

REMOVE:

1. (MK1) Remove aft and forward electric bilge pumps (refer to paragraph 3-143).
(MK2) Remove aft electric bilge pump (refer to paragraph 3-143).
Remove forward electric bilge pump (refer to paragraph 3-144).

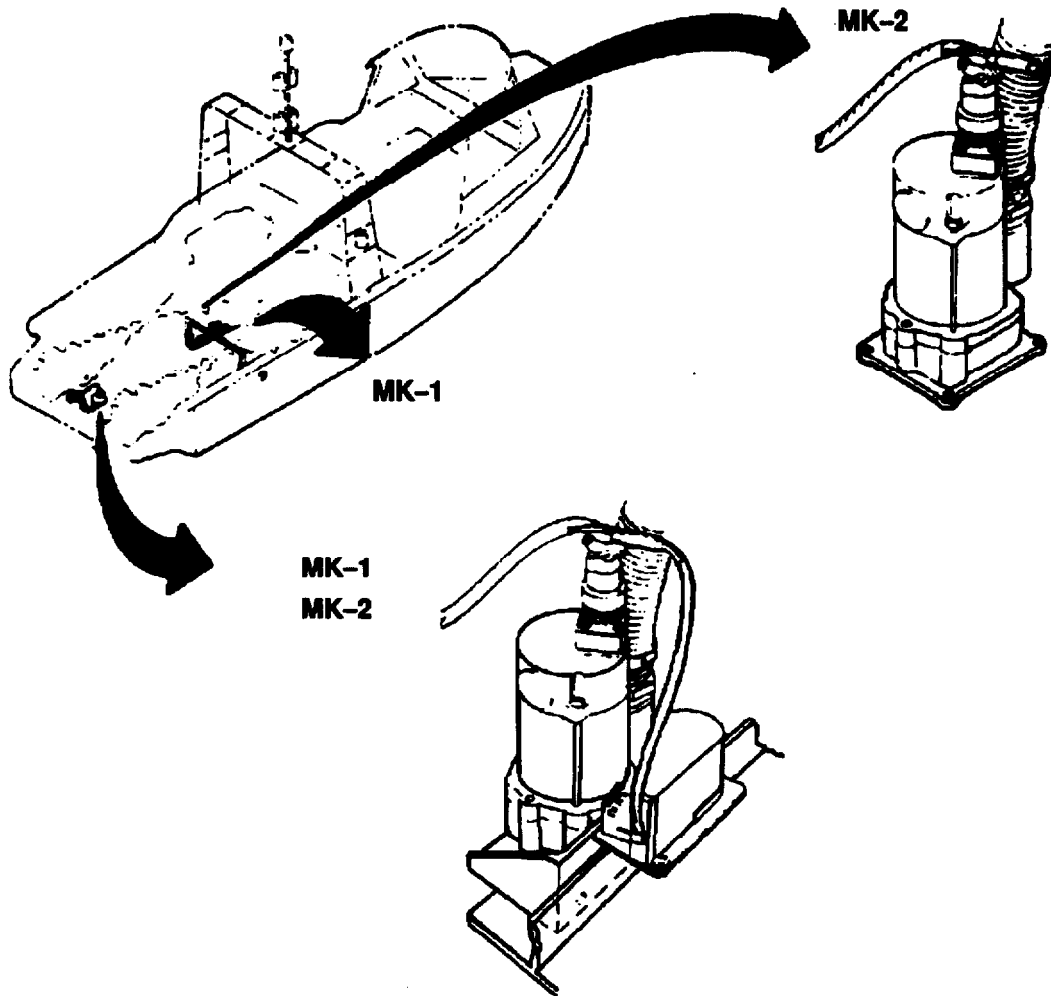

2. Inspect screen (1) for damage.
3. (MK1) Using impeller nut removal tool remove nut (2) and lockwasher (3).
(MK2) Using impeller nut removal tool remove nut (2), lockwasher (3) and flat washer (4).
4. Using two screwdrivers gently pry impeller (5) from shaft (6).

NOTE

Bronze impeller will be replaced with a plastic impeller and an additional flat washer.

Impeller is keyed to motor shaft with Woodruff key (7). When impeller is removed care should be taken to retain key.

5. (MK1) Discard bronze impeller.
(MK2) Inspect impeller (5) for damage and replace if required.
6. Using wrench, separate impeller housing (8) from motor (9) by removing two bolts (10) and lockwashers (11).
7. Remove gasket (12) and discard.
8. Using screwdriver remove two brush caps (13) from motor housing.
9. Lift out brushes (14) and inspect for wear. Replace if worn to 1/4 inch.

INSTALL:

NOTE

Brush must be installed with curved face in line with armature.

1. Install brushes (14) by inserting in motor housing. Install brush caps (13) and tighten using screwdriver.
2. Install replacement gasket (12) on impeller housing (8).
3. Fit motor (9) to impeller housing (8).
4. Install two bolts (10) thru lockwashers (11), impeller housing (8) and gasket (12) into motor (9).
5. Using wrench tighten bolts (10).
6. Install plastic impeller (5) on motor shaft (6) insuring Woodruff key (7) is alined with impeller keyway on motor shaft (6).
7. Install flat washer (4), lockwasher (3) and nut (2) on motor shaft (6) to secure impeller (5).
8. Tighten nut (2) with impeller nut tool.
9. (MK1) Install aft and forward electric bilge pumps (refer to paragraph 3-143).
(MK2) Install aft electric bilge pump (refer to paragraph 3-143).
(MK2) Install forward electric bilge pump (refer to paragraph 3-144).

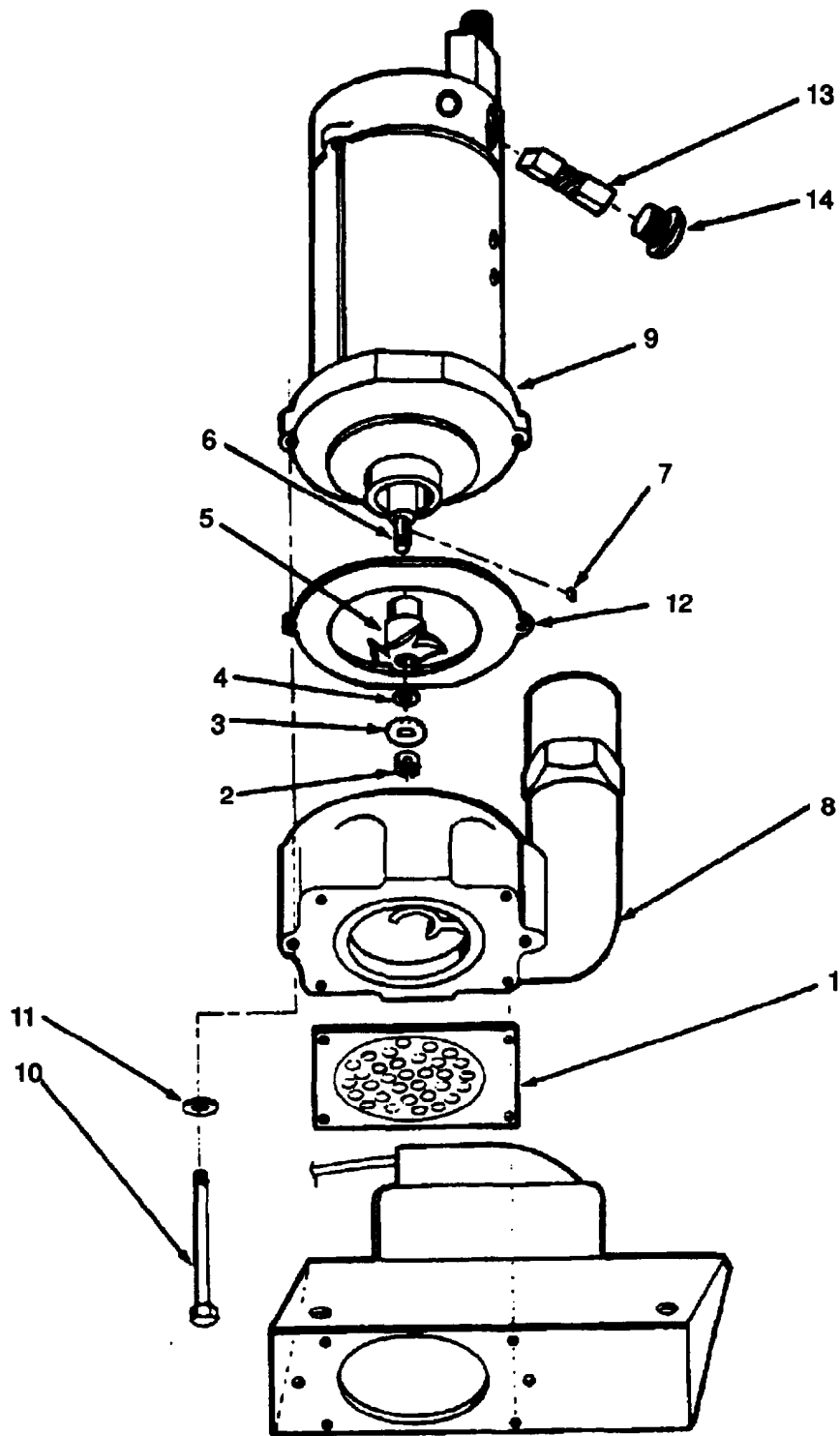

3-146. HAND BILGE PUMP ASSEMBLY REPLACEMENT INSTRUCTIONS (MK1)

TOOLS: Flat Tip Screwdriver, 4 inch
10 mm Box Wrench

PARTS/MATERIALS: Hand Bilge Pump Assembly

REMOVE:

1. Open access door (1) to stowage locker.

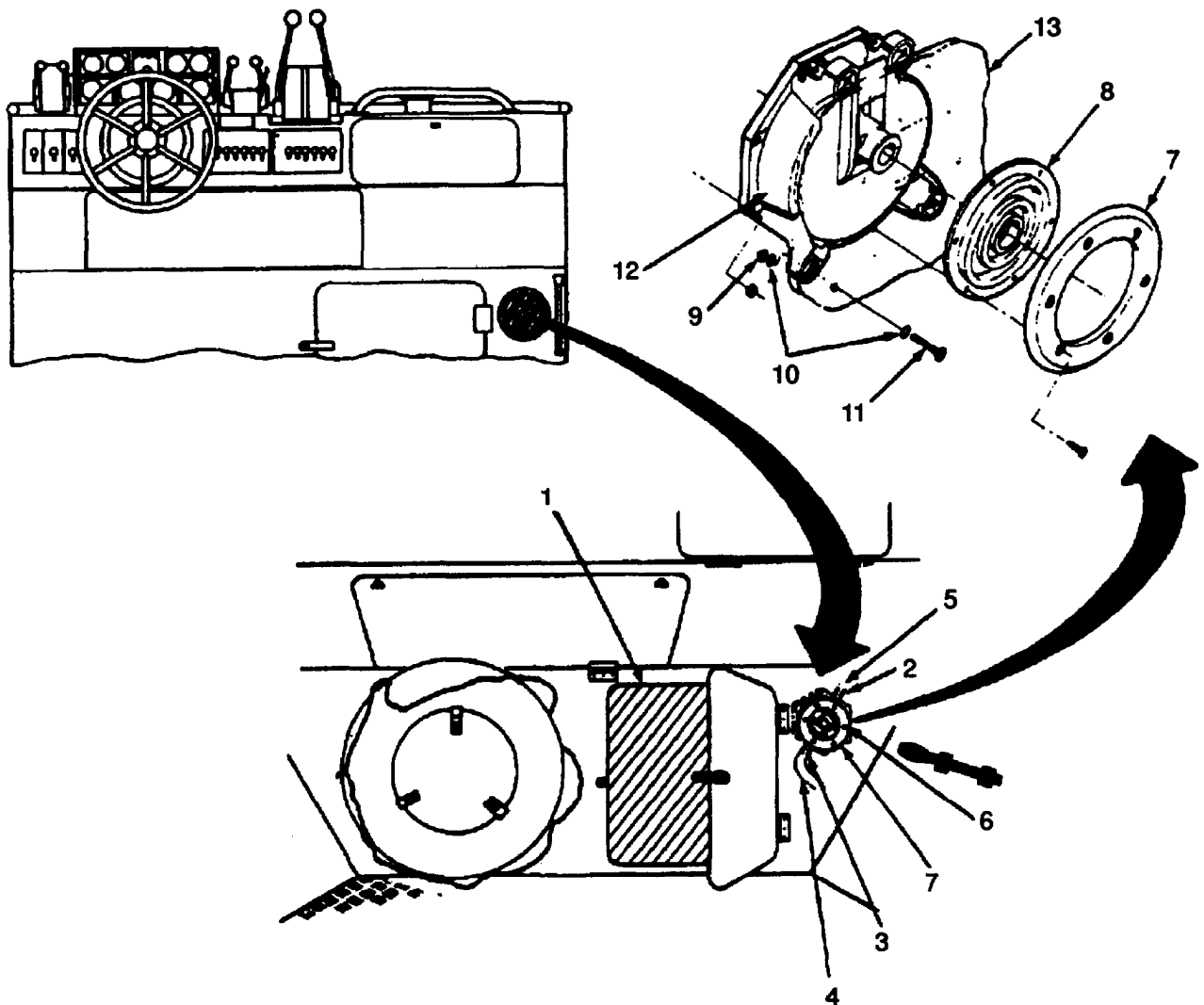

2. Using screwdriver loosen hose clamp (2) on pump inlet fitting and hose clamp (3) on pump outlet fitting.
3. Remove inlet (4) and outlet (5) hoses from fittings.
4. Using screwdriver remove six screws (6) from deck ring (7).
5. Remove deck ring (7) and deck seal (8).
6. Using screwdriver and wrench remove four nuts (9), eight washers (10) and four screws (11) which secure pump (12) to bulkhead.
7. Remove pump assembly (12) from position in stowage locker (13).

INSTALL:

1. Fit new pump assembly (12) in position.
2. Align holes in pump body and bulkhead. Install four screws (11), eight washers (10) and four nuts (9).
3. Tighten nuts (9) using screwdriver and wrench.
4. Install flex hose inlet (4) and outlet (5) to pump inlet and outlet fittings.
5. Position hose clamps [inlet (2) and outlet (3)] and tighten using screwdriver.
6. Fit deck seal (8) and deck ring (7) to pump aft of bulkhead section.
7. Align holes in deck ring, deck seal and bulkhead.
8. Install six screws (6) through deck ring (7) and deck seal (8) into bulkhead.
9. Tighten using screwdriver.
10. Close stowage locker access door (1).

3-147. HAND BILGE PUMP ASSEMBLY REPAIR INSTRUCTIONS (MK1)

TOOLS: Flat Tip Screwdriver, 4 inch
1-1/8 inch Open End Wrench

PARTS/MATERIALS: Outlet Valve
Pump Diaphragm
Inlet Valve
Cover Seal

REMOVE:

1. Remove hand bilge pump assembly (refer to paragraph 3-146).

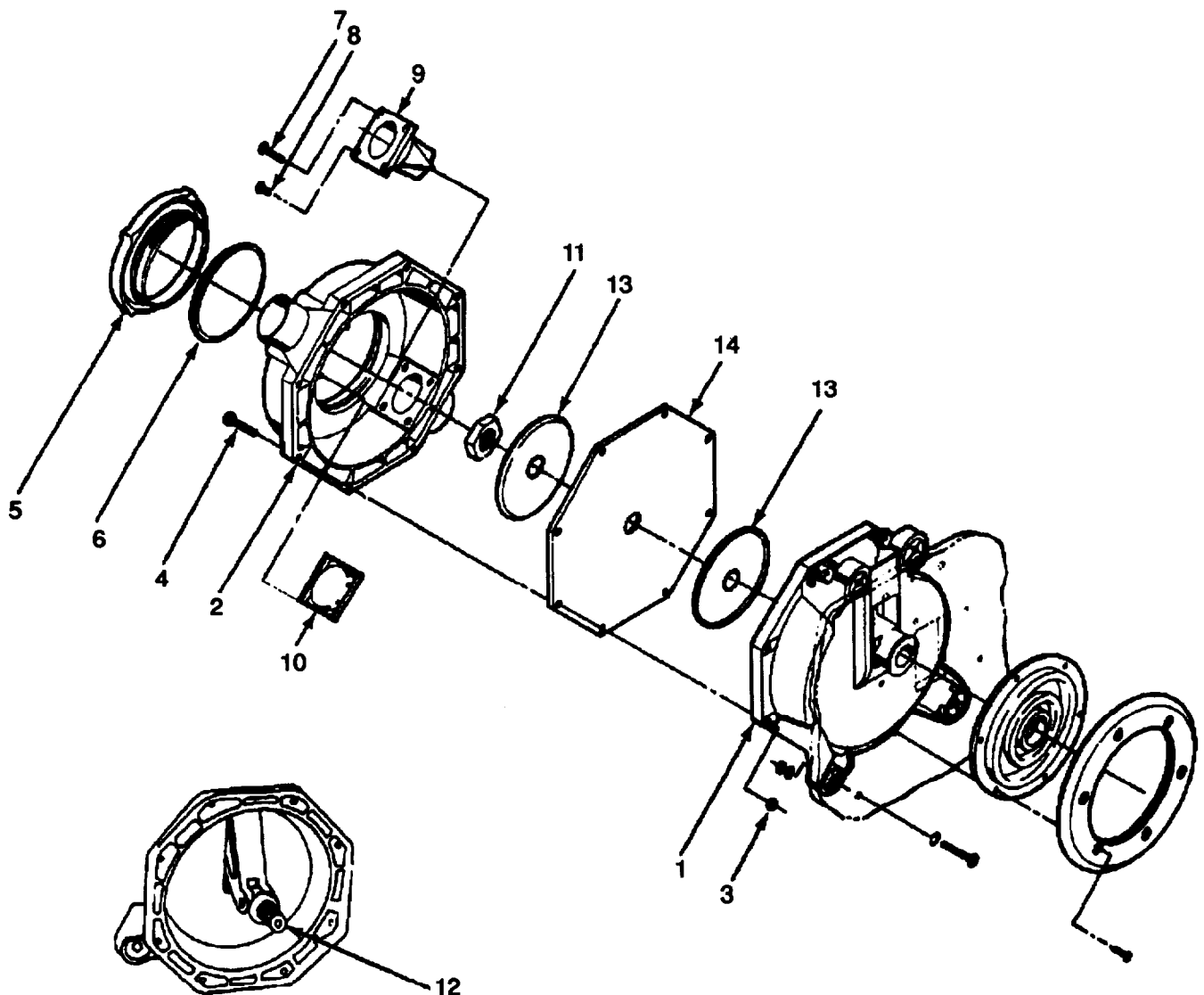

2. Using screwdriver disassemble pump rear cover (1) from pump body (2) by removing eight nuts (3) and screws (4).
3. Remove top cover (5) from pump body (2).
4. Remove cover seal (6) from top cover (5). Discard cover seal (6).
5. Using screwdriver remove four screws (7 and 8) and outlet valve (9) from pump body (2). Discard outlet valve (9).
6. Slide inlet valve (10) out of position and discard.
7. Using wrench remove rocker arm nut (11) from rocker arm (12) located on pump rear cover (1).
8. Remove diaphragm plates (13) and diaphragm (14). Discard diaphragm (14).
9. Clean and inspect rear cover (1), pump body (2) and diaphragm plates (13).

INSTALL:

1. Install diaphragm plates (13) and new diaphragm (14) on rocker arm (12).
2. Install rocker arm nut (11) on rocker arm and tighten using wrench.
3. Install new inlet valve (10).
4. Install new outlet valve (9) and four screws (7 and 8) and tighten using screwdriver.
5. Install new cover seal (6) and top cover (5) on pump body (2).
6. Assemble pump rear cover (1) and pump body (2). Insure alinement of inlet and outlet fittings.
7. Aline holes in diaphragm (14) with holes in rear cover (1) and pump body (2).
8. Insert eight screws (4) thru pump body (2), diaphragm (14) and rear cover (1).
9. Install eight nuts (3) and tighten using screwdriver.
10. Install hand bilge pump assembly (refer to paragraph 3-146).

3-148. AUTOMATIC FIRE EXTINGUISHER REPLACEMENT INSTRUCTIONS

TOOLS: Two 1/2 inch Box Wrenches

PARTS/MATERIALS: Automatic Fire Extinguisher

REMOVE:

1. Open and secure engine hatches (refer to paragraph 3-154).

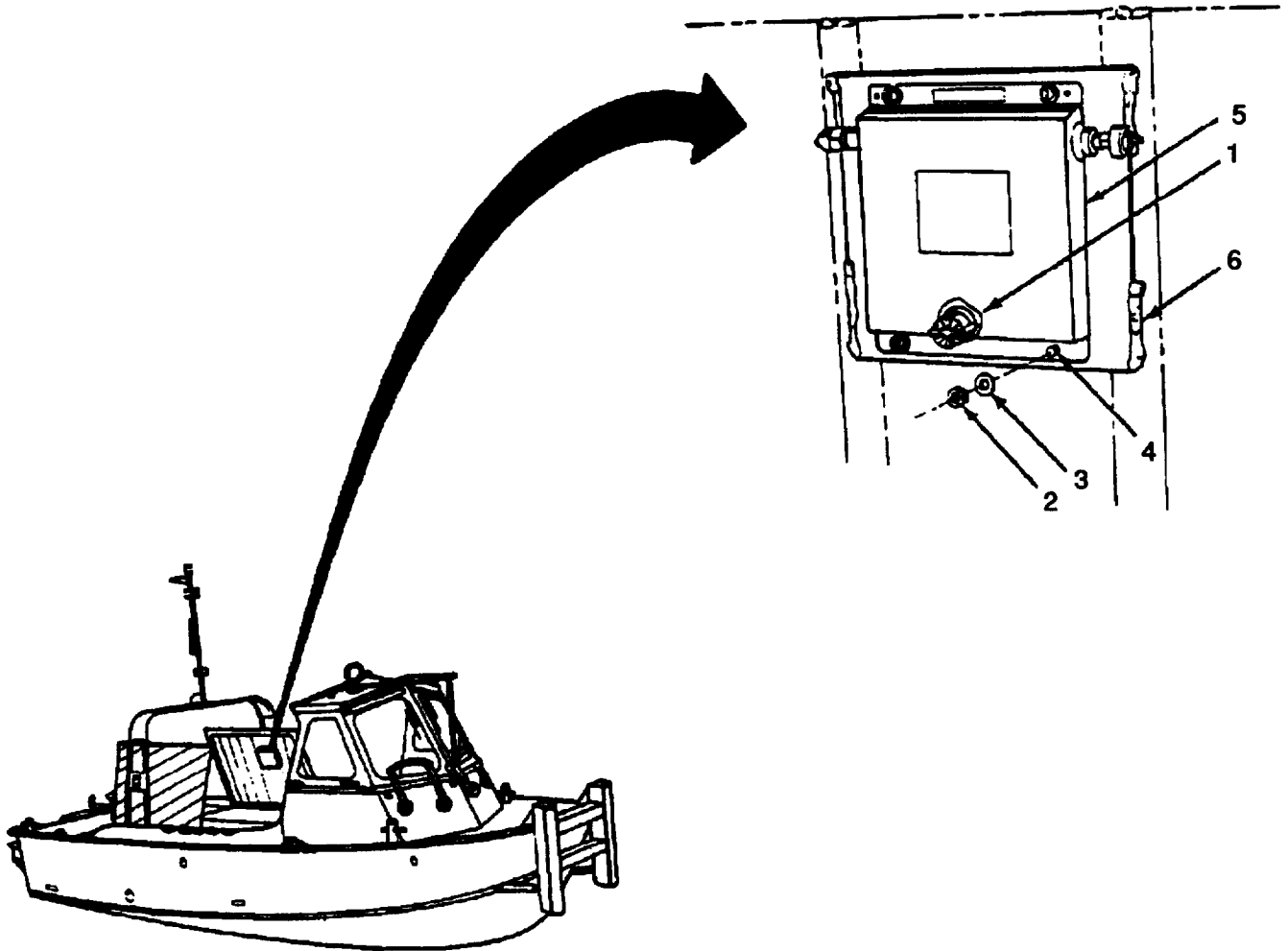

CAUTION

Heat or damage to sensor spray nozzle (1) could release any compound left in fire extinguisher.

2. Using two 1/2 inch box wrenches remove four nuts (2) and washers (3) from bolts (4) releasing fire extinguisher unit (5) from bracket (6).

INSTALL:

CAUTION

Heat or damage to sensor spray nozzle will cause fire extinguisher unit to discharge.

1. Place new fire extinguisher unit (5) on bracket (6) and align holes.
2. Install four bolts (4), washers (3) and nuts (2) in bracket (6).
3. Using two 1/2 inch box wrenches tighten bolts (4) and nuts (2) to secure fire extinguisher (5) to bracket (6).
4. Close engine hatches.

3-149. HAND FIRE EXTINGUISHER REPLACEMENT INSTRUCTIONS

TOOLS: None

PARTS/MATERIALS: Hand Fire Extinguisher

REMOVE:

CAUTION

Striking discharge nozzle on hard surface may cause fire extinguisher to discharge.

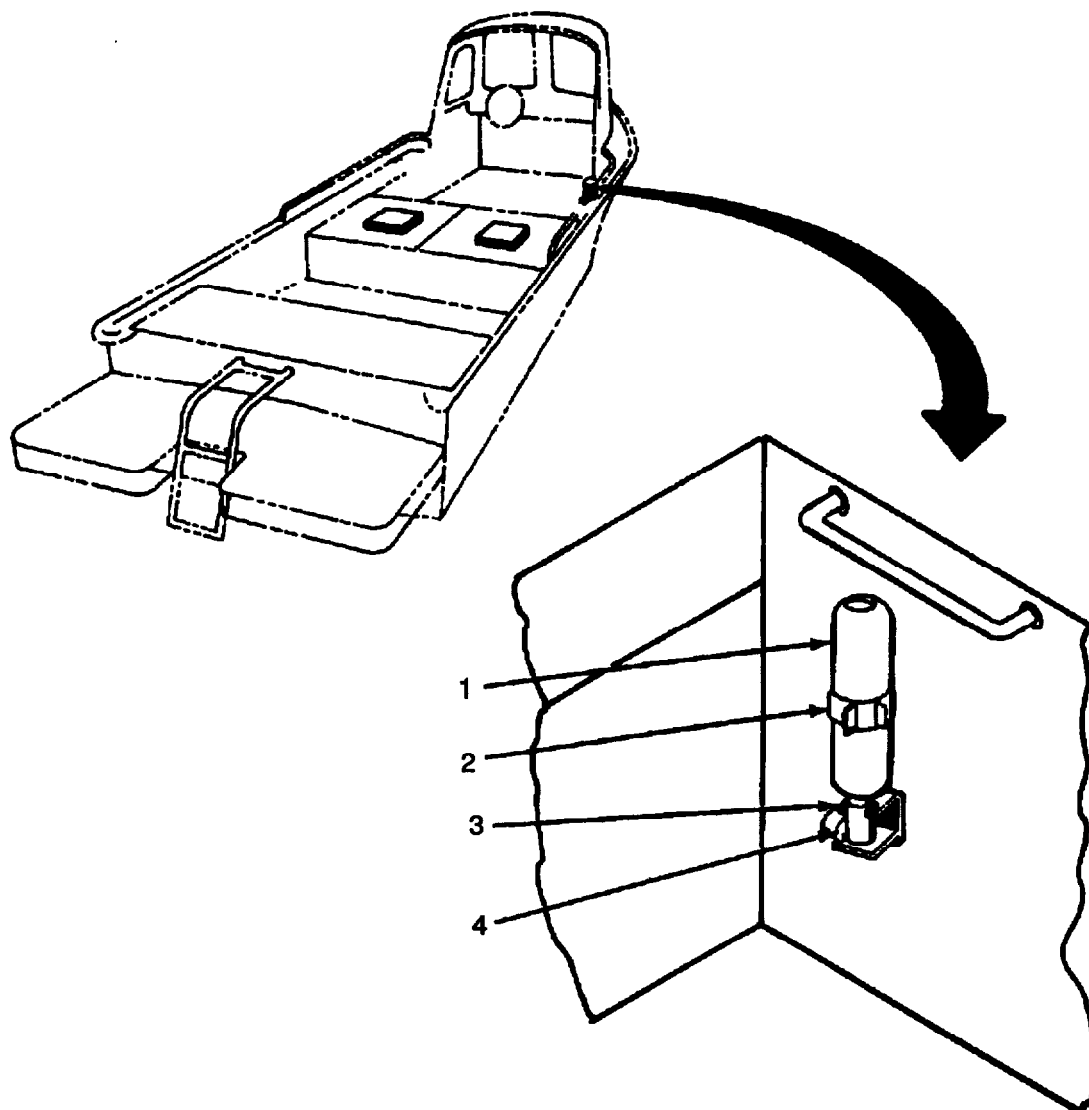

1. Hold fire extinguisher (1) firmly with one hand and release retaining strap (2) which holds fire extinguisher (1) on bracket (3).
2. Lift fire extinguisher (1) from bracket (3).
3. Discard fire extinguisher (1).

INSTALL:

1. Position replacement fire extinguisher (1) in bracket (3) with discharge nozzle (4) down and pointed toward boat hull.
2. Aline fire extinguisher (1) in mounting bracket (3), secure retaining strap (2) and lock into position.

3-150. KEEL ANODES REPLACEMENT INSTRUCTIONS

TOOLS: 17 mm Socket
17 mm Box Wrench
Ratchet

PARTS/MATERIALS: Keel Anodes
Degreasing Solvent (Item 10, Appendix C)
Steel Wool (Item 15, Appendix C)
Liquid Detergent and Water Solution (Item 5, Appendix C)

PERSONNEL REQUIRED: Two

NOTE

The boat must be out of water on cradle to perform this service.

WARNING

Replacing the two anodes (4 and 5) requires personnel to work directly under the boat. Take special precautions to ensure boat is securely supported.

REMOVE:

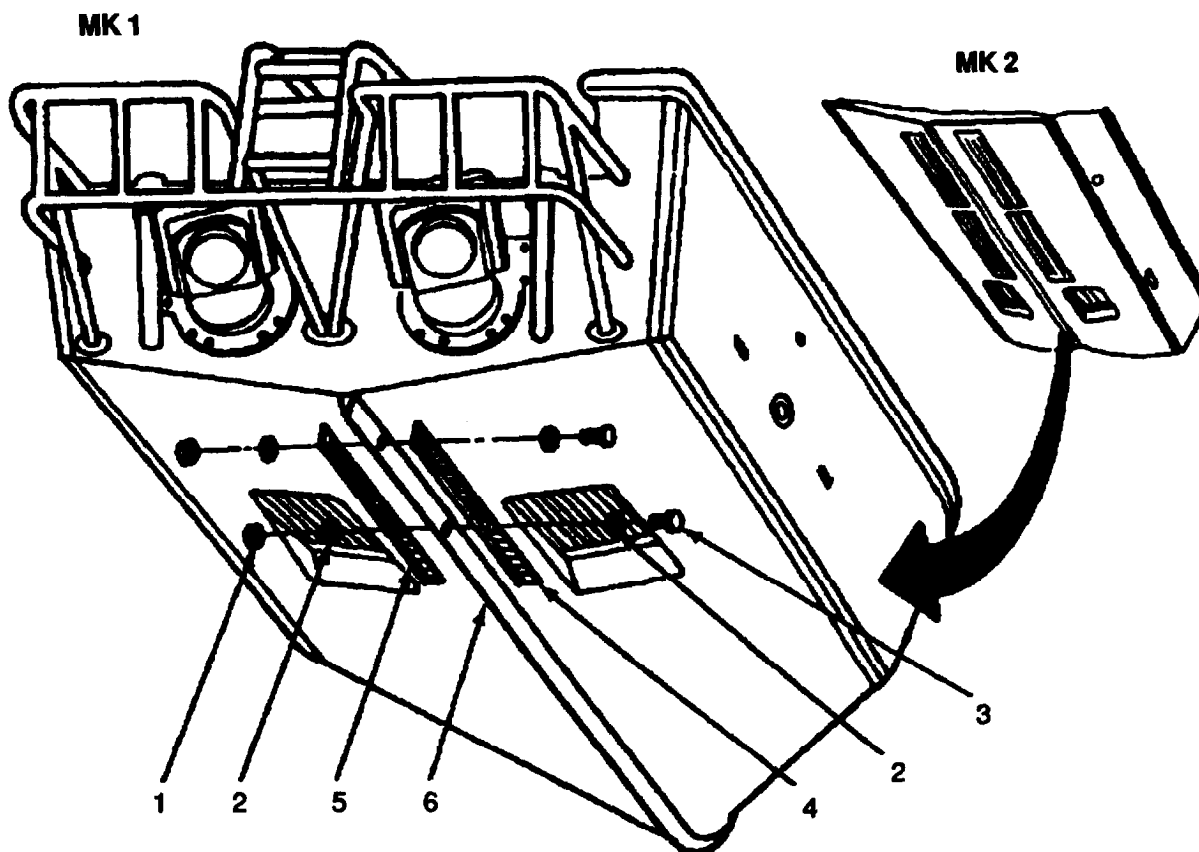

1. Using socket and wrench remove two nuts (1), four washers (2) and two bolts (3) securing starboard (4) and port (5) anodes to keel (6).
2. Discard old anodes.
3. Clean corrosion from surfaces of keel (6) to bare metal using degreasing solvent and steel wool. Wash with soap and water solution and dry.

INSTALL:

1. Place starboard anode (4) alongside keel (6) and align mounting holes.
2. Install washers (2) and two bolts (3) and insert thru starboard anode (4) and keel (6).
3. Fit port anode (5) to keel (6) and push bolts (3) thru holes.
4. Install two washers (2) and nuts (1) and tighten nuts (1) using wrench and socket.

3-151. FENDERING (RUBBER RUB RAIL) REPLACEMENT INSTRUCTIONS

TOOLS: Ratchet 3/8 in. Drive
13 mm Socket w/(3/8 in. Drive)
6 inch Extension
Electric Drill
1/2 inch Drill
1-1/4 inch Hole Cutter
13 mm Box End Wrench

PARTS/MATERIALS: Fendering (Rub Rail) Replacement Section

PERSONNEL REQUIRED: Two

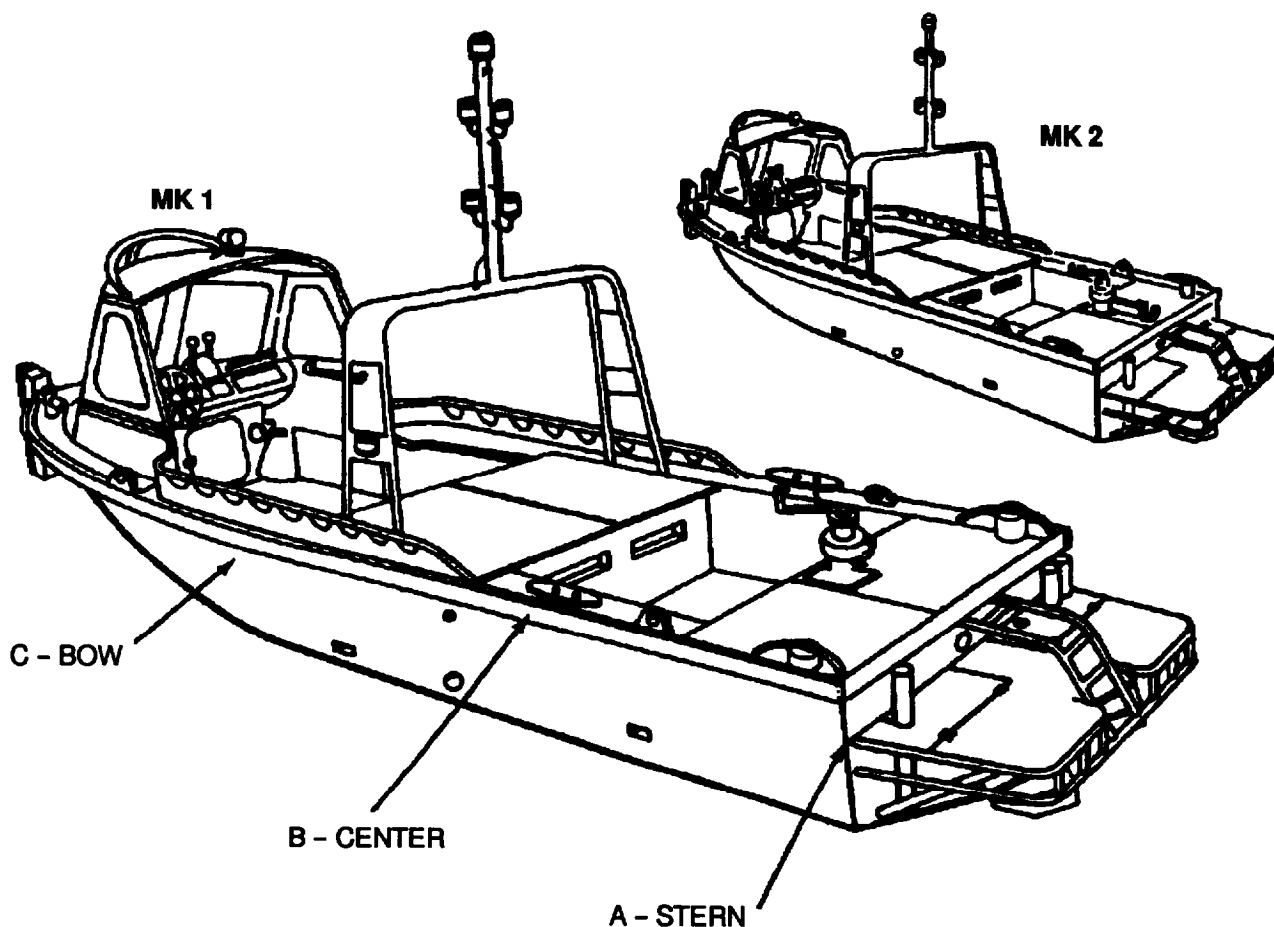

NOTE

The fendering (rubber rub rail) is fitted in three sections from stern to bow on each side (port or starboard). These fendering (rubber rub rail) sections are held in place by metal inserts extending from bow to stern. The stern section (A) must be removed to replace the center section (B). Both the stern section (A) and center section (B) must be removed to replace the bow section (C). Ensure that 1-3/4 inch bolt is installed through metal insert at second from last hole on Section A.

REMOVE:

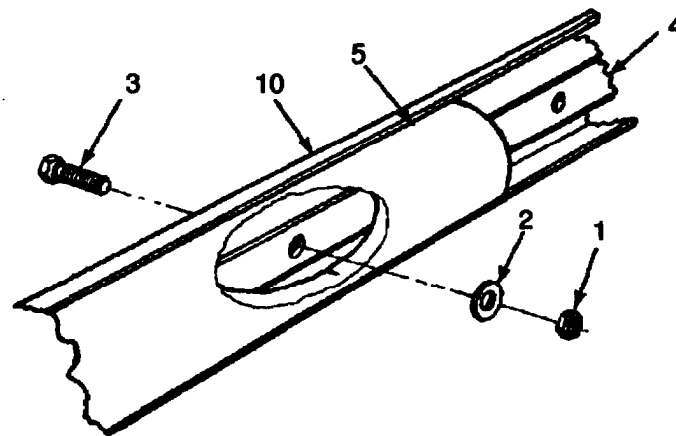

1. Using socket on extension remove nuts (1) and washers (2).
2. Remove bolts (3) by pushing inward to clear metal insert (4) and flat section of fendering (rub rail).

NOTE

Fendering (rub rail) is removed by sliding it towards the stern after bolts are removed.

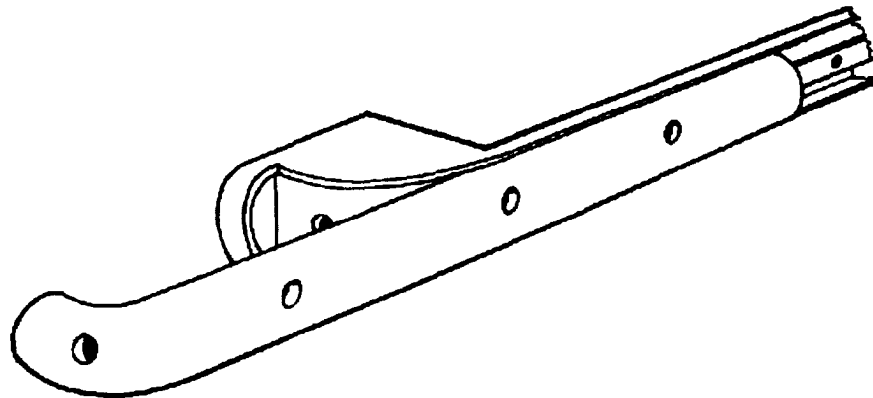

3. Remove section of fendering (rub rail) (5) from boat and lay out on flat surface.

CAUTION

Drill through fendering (rubber rub rail) at slow speed to prevent burning.

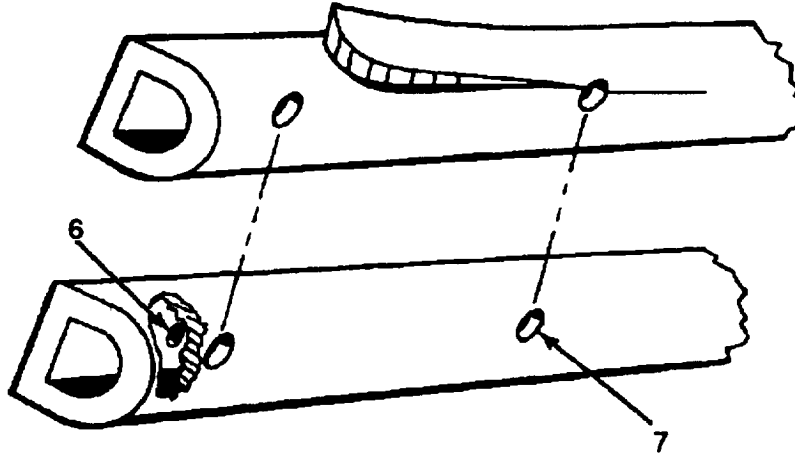

4. Using old section of fendering (rubber rub rail) as guide, locate and drill 1/2 inch holes (6) in flat side of new section of rub rail.
5. Locate and drill socket access holes (7) in curved side of fendering (rub rail) using hole cutter.
6. Discard old fendering (rub rail).

INSTALL:

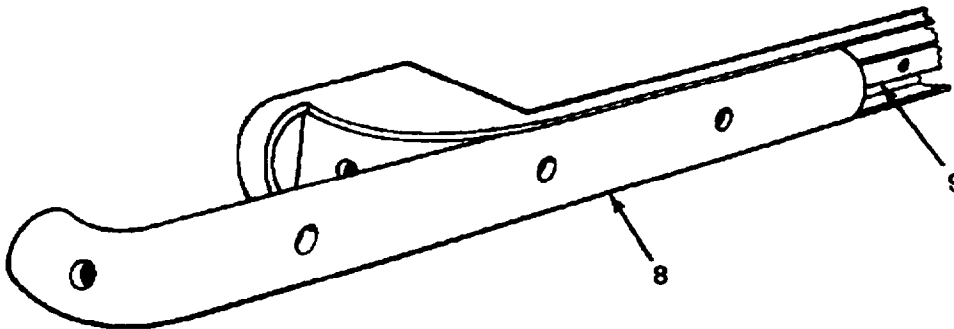

1. Slide new section (8) of fendering (rub rail) into position on metal insert (9).
2. From inside of boat insert bolts (3) through gunwale (10), fendering (rubber rub rail) (5) and metal insert (4).

NOTE

Bolt heads must be flush with flange an gunwale so that bolt will not turn when metal insert and fendering (rub rail) are installed and nut is attached.

3. Replace washers (2) and nuts (1) through fendering (rubber rub rail) and tighten using socket and extension.

3-152. BUOYANCY MATERIAL REMOVAL AND INSTALLATION INSTRUCTIONS

TOOLS: None Required

REPLACEMENT CRITERIA: Blocks will be replaced if oil or fuel soaked (not stained), if cracked through, or if large chunks broken out. Missing buoyancy material must not exceed 5% of total volume of

REMOVE: (ENGINE COMPARTMENT (Block No. 29 thru 36)

NOTE

Buoyancy blocks are numbered on the back or side and must be removed before number is visible.

REMOVE:

1. Open and secure engine hatches (refer to paragraph 3-154).

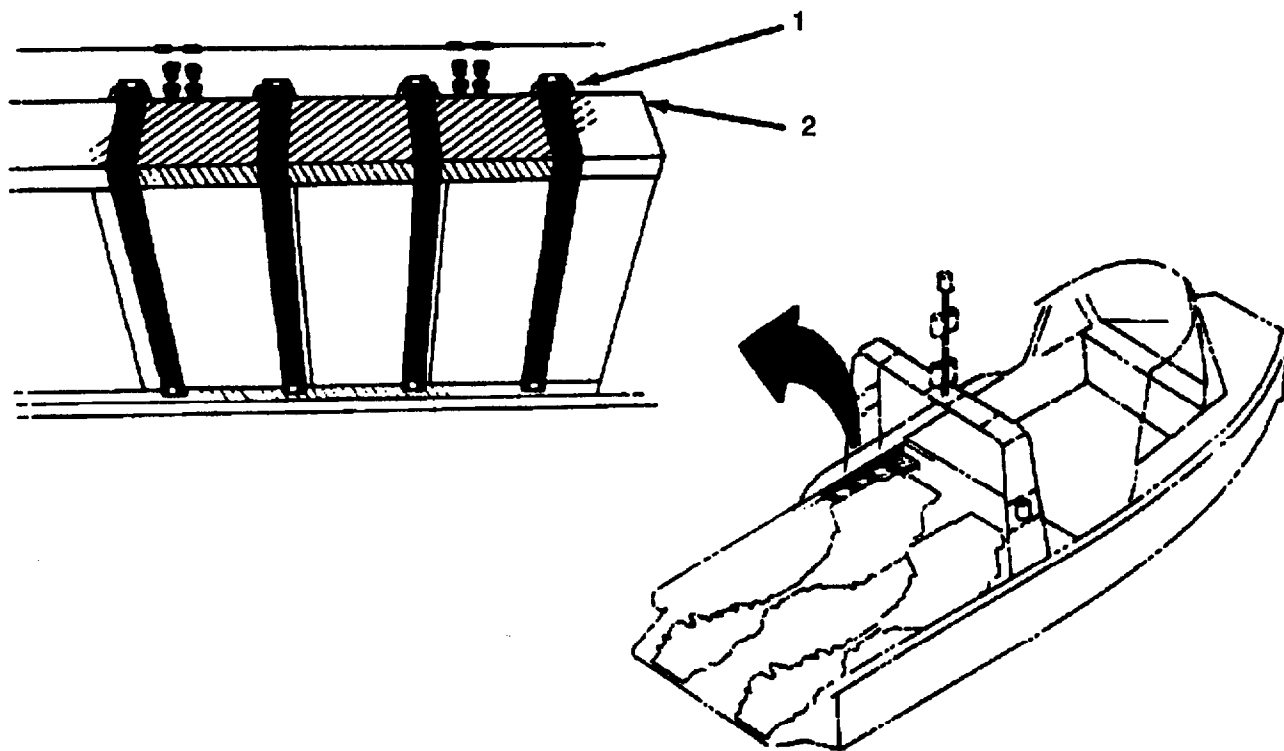

2. Unbuckle four nylon straps (1) securing holding plate (2).
3. Remove holding plate (2) and store out of work area.

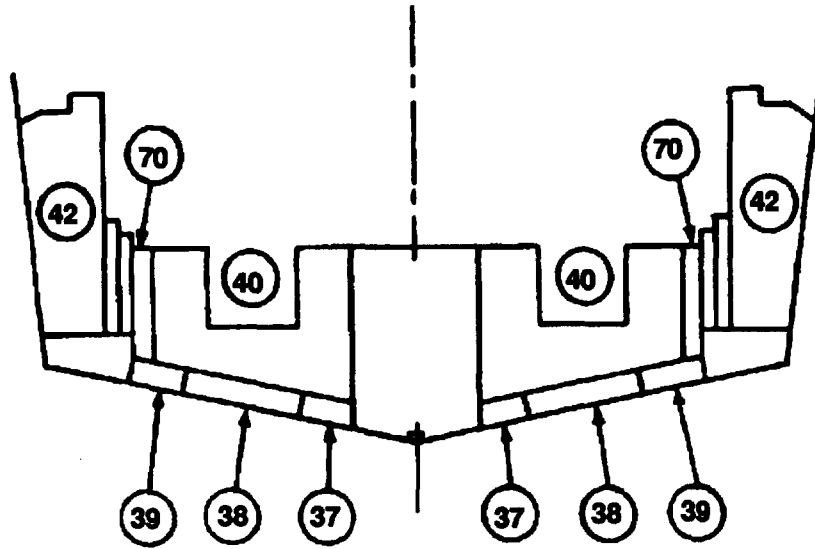

BLOCK PLACEMENT DIAGRAM CROSS-SECTION (MK 1)

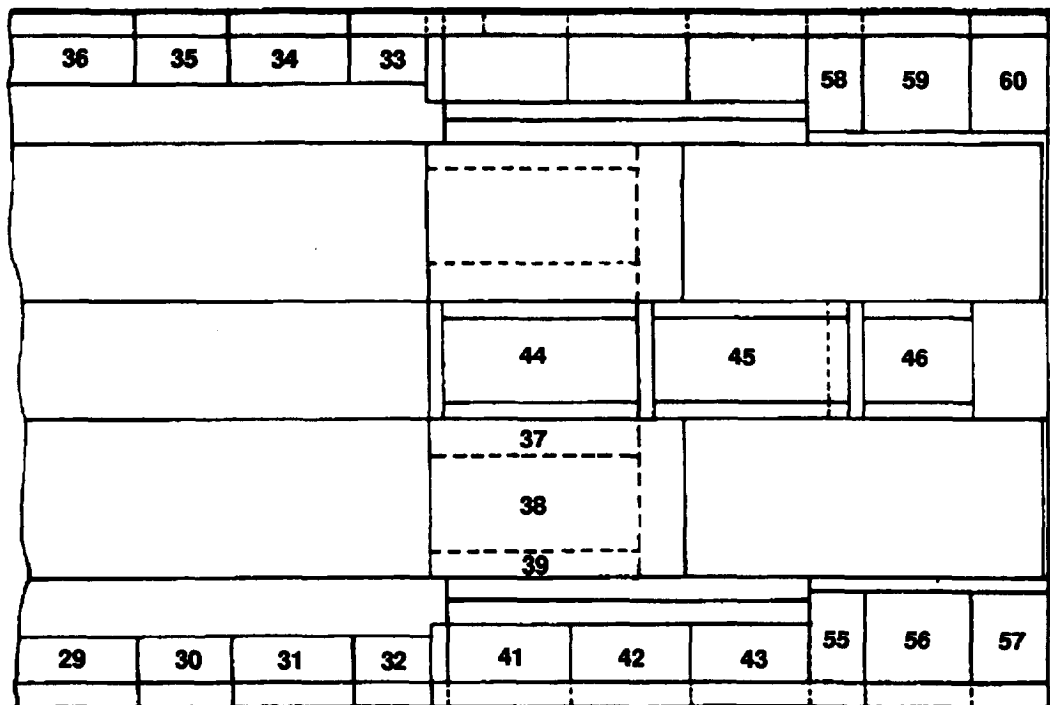

← BOW STERN →

BLOCK PLACEMENT DIAGRAM (MK 1)

NOTE

Refer to buoyancy block placement diagram for block numbers for next step.

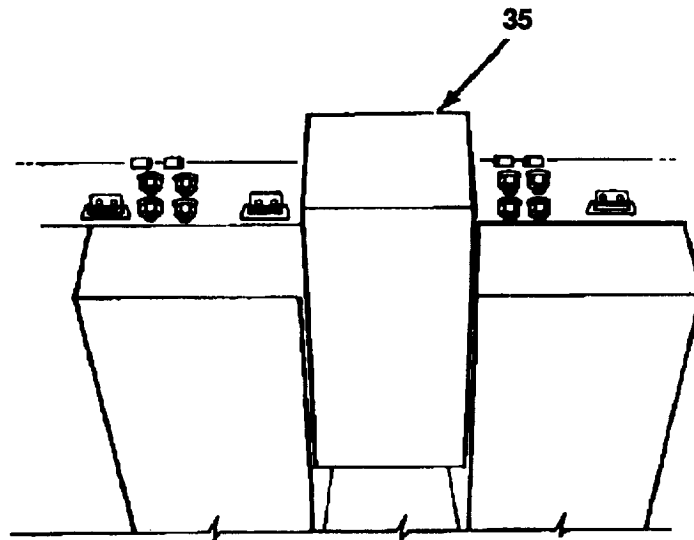

4. Remove key buoyancy block (number 35 on starboard or number 30 on port).
5. Remove remaining buoyancy blocks by sliding left or right toward the center, inward then upward and out.
6. Place blocks aside or discard as required.
7. Move nylon straps out of work area.

INSTALL: (ENGINE COMPARTMENT - Block No. 29 thru 36)

1. Clean area where buoyancy blocks are to be installed and move nylon straps into position for mounting.
2. Install outer buoyancy blocks by inserting into center of mounting area and sliding blocks left or right (refer to block placement diagram).
3. Install key block (number 35 on starboard or number 30 on port).
4. Install holding plate (2) with curved flange over inward edge of buoyancy blocks.
5. Buckle four nylon straps (1) and tighten.
6. Close engine hatches.

REMOVE: (HYDROJET COMPARTMENT (Block No. 55 thru 60)

1. Open and secure hydrojet compartment hatches (refer to paragraph 3-154).

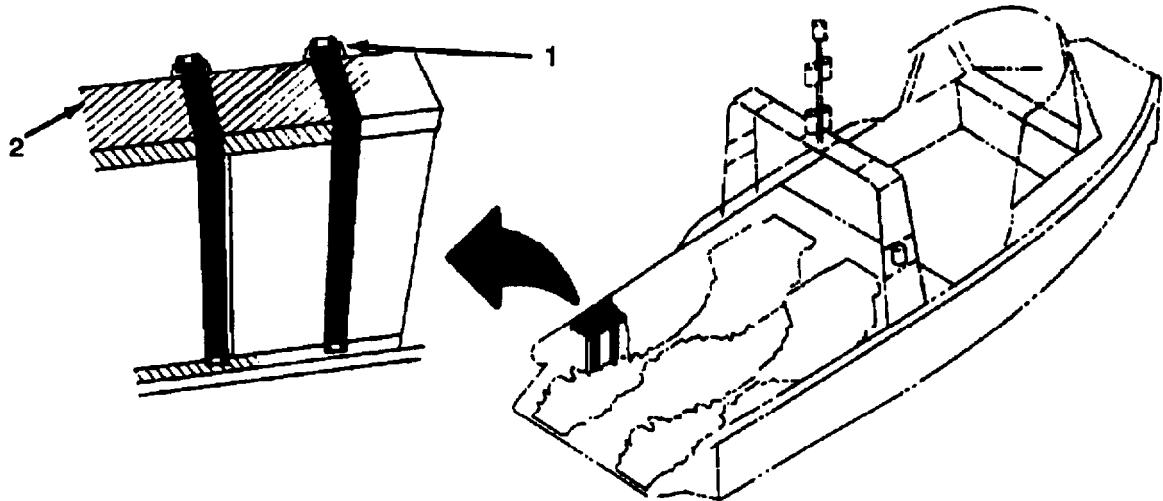

2. Unbuckle two nylon straps (1) securing holding plate (2).
3. Remove holding plate (2) and store out of work area.

NOTE

Refer to buoyancy block placement diagram for block numbers for next step.

4. Remove key buoyancy block (number 59 on starboard or number 56 on port) and place aside or discard as required.
5. Remove remaining buoyancy blocks by sliding left or right toward center, inward then upward and out and place aside or discard as required.
6. Move nylon strap out of work area.

INSTALL: (HYDROJET COMPARTMENT (Block No. 55 thru 60)

1. Clean area where buoyancy blocks are to be installed and move nylon straps into position for mounting.
2. Install outer buoyancy blocks by inserting into center of mounting area and sliding blocks left or right (refer to block placement diagram).
3. Install key block (number 59 on starboard or number 56 on port).
4. Install holding plate (2) with curved flange over inward edge of buoyancy blocks.
5. Buckle two nylon straps (1) and tighten.
6. Close hydrojet compartment hatches.

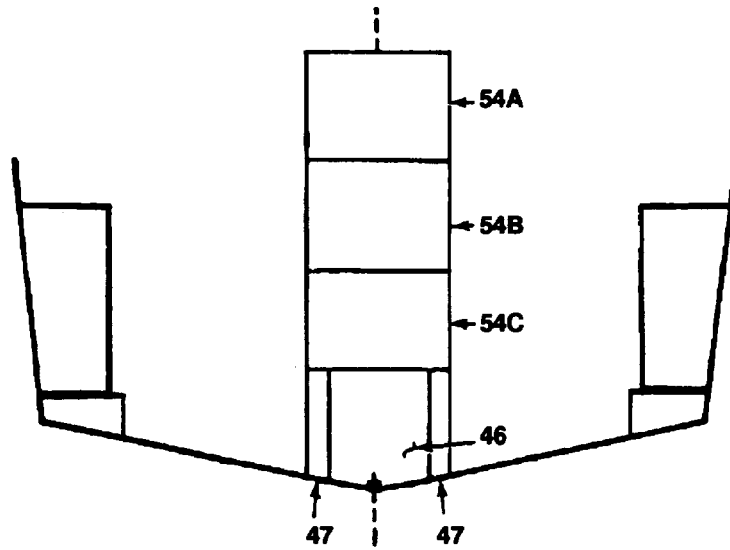

BLOCK PLACEMENT DIAGRAM CROSS-SECTION (MK-2)

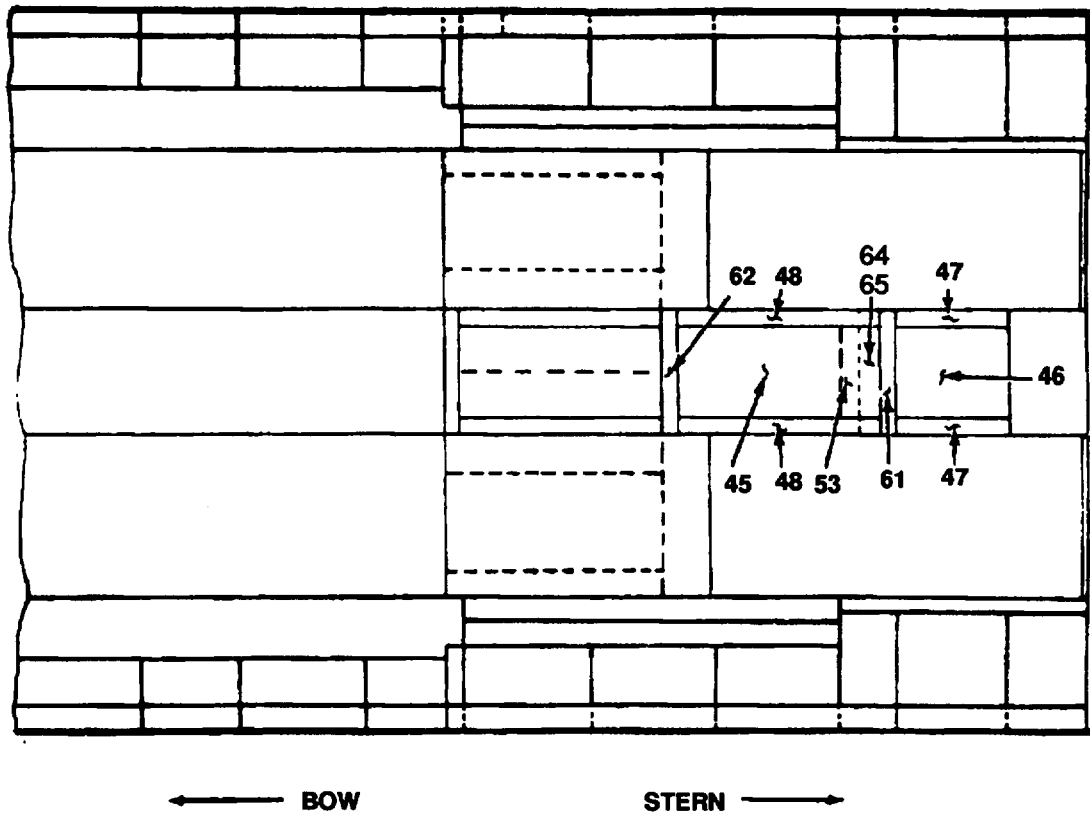

BLOCK PLACEMENT DIAGRAM (MK 2)

REMOVE: (MK2 HYDROJET COMPARTMENT - Block No. 45 through 48, 53, 54A through 54D, 61, 62, 64, and 65)

1. Open and secure hydrojet compartment hatches (refer to paragraph 3-154).
2. Remove aft cockpit (refer to paragraph 3-27).
3. Unbuckle two nylon straps (1) securing buoyancy blocks (2) from steering jet linkage and secure straps away from work area.

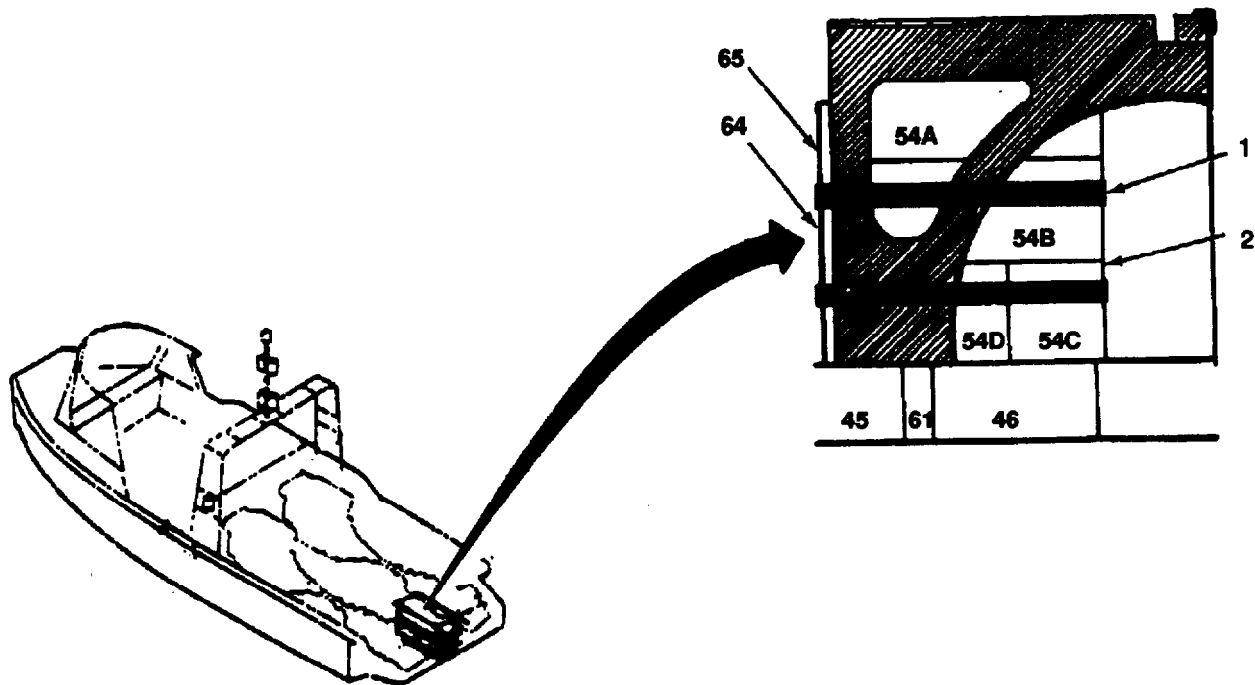

NOTE

Buoyancy blocks number (46) and (54A) through (54D) may have been separated into two or more smaller sections.

4. Remove blocks number (54A) through (54D), and (46) and place aside or discard as required.
5. Lift out blocks number (47) and (61), and place aside or discard as required.
6. Remove block number (53) and place aside or discard as required.
7. Remove blocks number (64) and (65) by tilting forward and lifting out from recessed area. Place aside or discard as required.

NOTE

Refer to buoyancy block placement diagram for block numbers for next step.

8. Lift out block number (45) (48) and (62). Place blocks aside or discard as required.

INSTALL: (MK2 HYDROJET COMPARTMENT - Block No. 45 through 48, 53, 54A through 54D, 61, 62, 64, and 65)

1. Clean area where buoyancy blocks are to be installed.

NOTE

For steps 2 through 8, refer to buoyancy block placement diagram located in the preceding pages of this paragraph.

2. Install block number (62).
3. Install blocks number (48) and (45).
4. Install block number (64) into slot in block number (65) and install in recessed seat on hull.
5. Install block number (53).
6. Install blocks number (61) and (47).

NOTE

Buoyancy blocks number (46) and (54A) through (54D) may have to be separated into two or more smaller sections before installation into confined area can be achieved.

7. Install block number (46).
8. Install blocks number (54A) through (54D).
9. Buckle two nylon straps (1) and tighten.
10. Install aft cockpit (refer to paragraph 3-27).
11. Close hydrojet hatches (refer to paragraph 3-154).

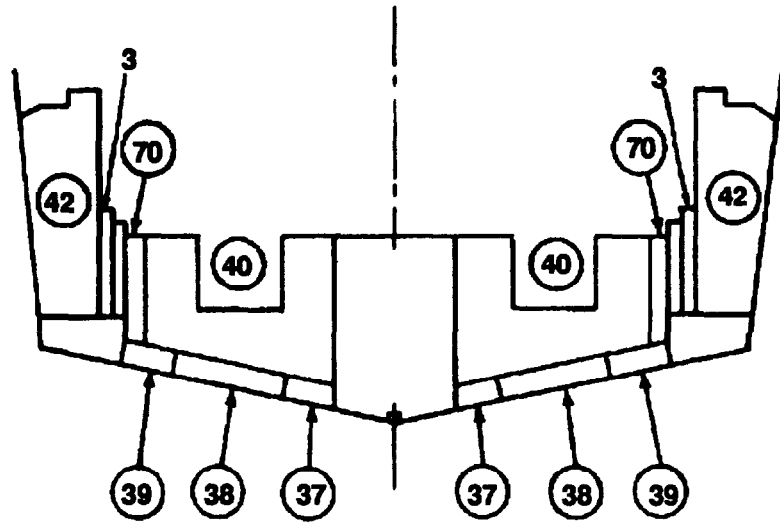

BLOCK PLACEMENT DIAGRAM CROSS-SECTION (MK 1)

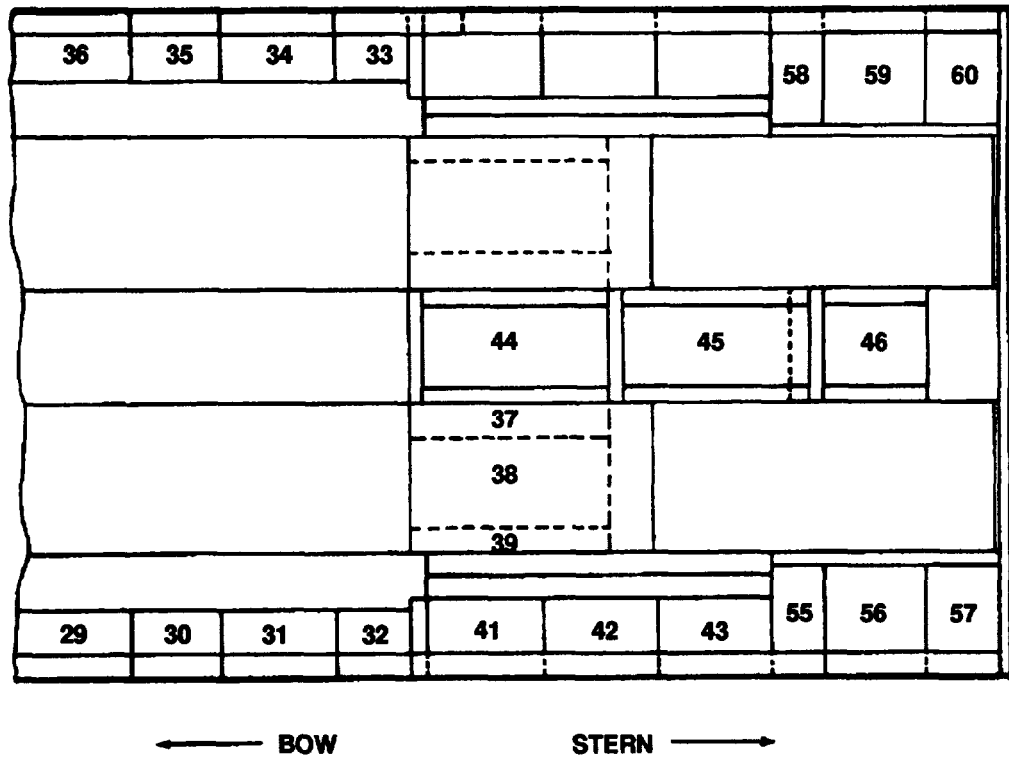

BLOCK PLACEMENT DIAGRAM (MK 1)

REMOVE: (MK1 AFT COCKPIT AND DRIVE SHAFT COMPARTMENT SIDE - Block No. 41 thru 43)

1. Remove aft cockpit (refer to paragraph 3-27).
2. Lift two wedge blocks (3) out of position (refer to block placement diagram and to block placement cross-section diagram) and place aside or discard as required.
3. Tilt block number (42) toward boat centerline and lift out and place aside or discard as required.
4. Slide remaining blocks either left or right, tilt toward centerline and lift out and set aside or discard as required.

INSTALL: (MK1 AFT COCKPIT AND DRIVE SHAFT COMPARTMENT SIDE - Block No. 41 thru 43)

1. Clean area where blocks are to be installed.
2. Install end blocks by inserting into center of mounting area and sliding blocks left or right (refer to block placement diagram).
3. Install key block (number 42).
4. Install wedge blocks (3) (refer to block placement diagram cross-section).
5. Install aft cockpit (refer to paragraph 3-27).

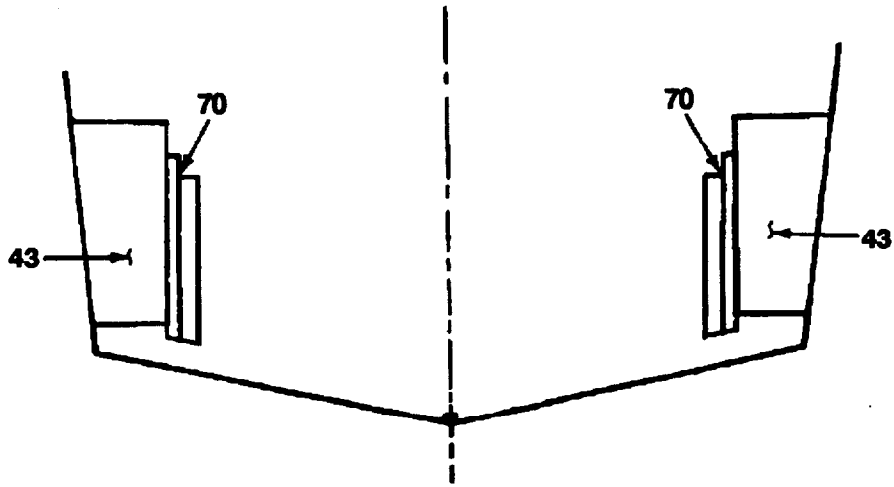

BLOCK PLACEMENT CROSS-SECTION (MK 2)

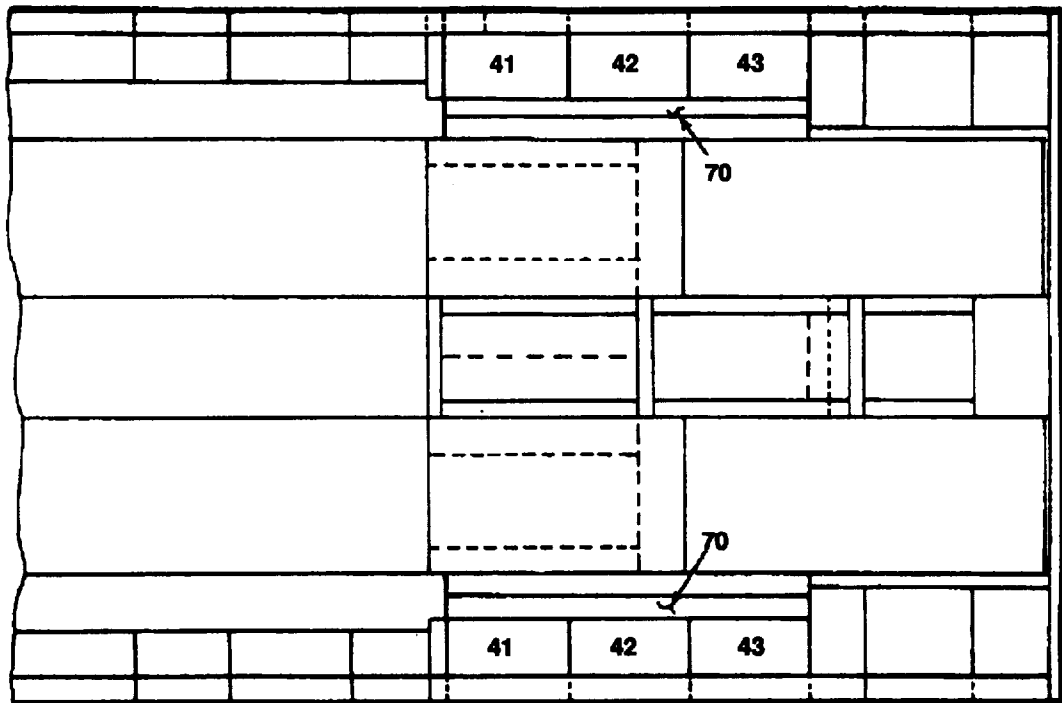

← BOW STERN →

BLOCK PLACEMENT DIAGRAM (MK 2)

REMOVE: (MK2 AFT COCKPIT AND DRIVE SHAFT COMPARTMENT SIDE - Block No. 41 thru 43 and 70)

1. Remove aft cockpit (refer to paragraph 3-27).

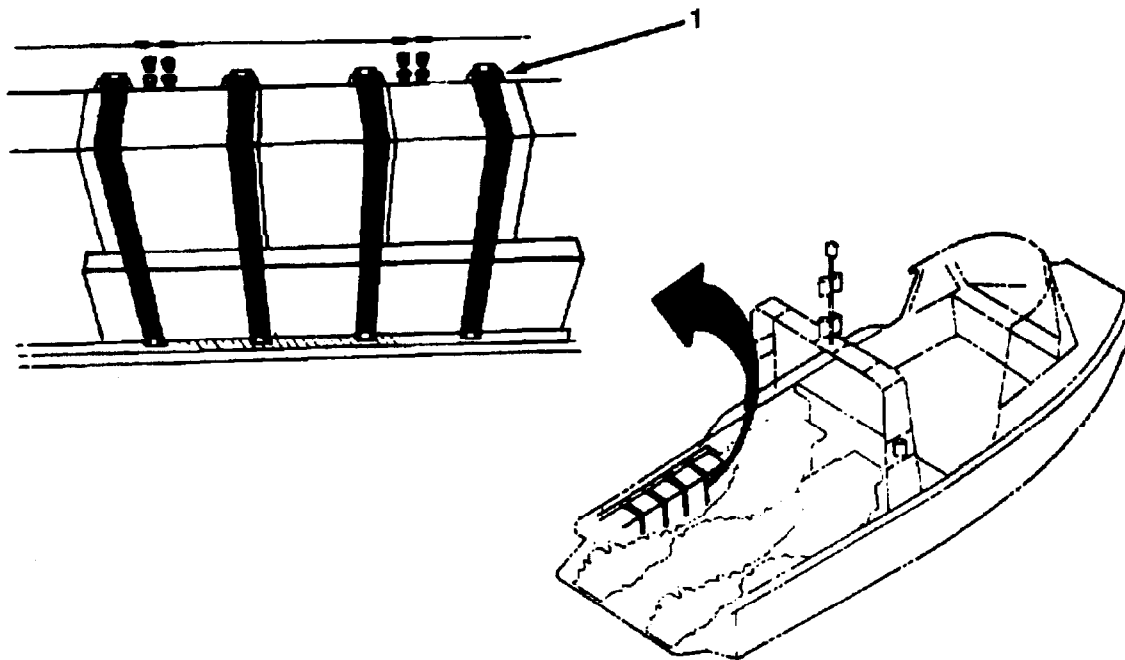

2. Unbuckle four nylon straps (1) securing block (41), (42), (43), and (70).
3. Lift out block (70) and place aside or discard as required.
4. Tilt block number (42) toward boat centerline and lift out and place aside or discard as required.
5. Slide remaining blocks either left or right, tilt toward centerline and lift out and set aside or discard as required

INSTALL: (MK2 AFT COCKPIT AND DRIVE SHAFT COMPARTMENT SIDE - Block No. 41 thru 43 and 70)

1. Clean area where blocks are to be installed.

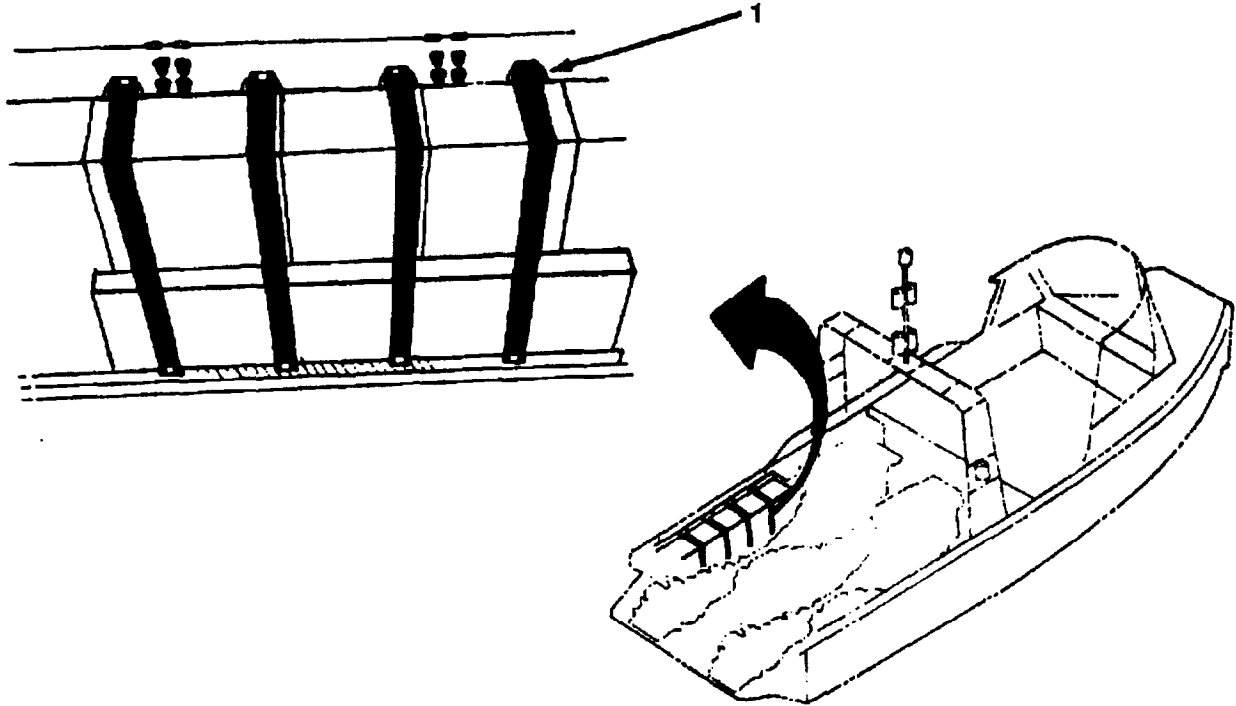

2. Install end Mocks by inserting into center of mounting area and sliding blocks left or right (refer to block placement diagram).
3. Install key block (number 42).
4. Install block (70) (refer to block placement diagram cross-section), and buckle four straps (1).
5. Install aft cockpit (refer to paragraph 3-27).

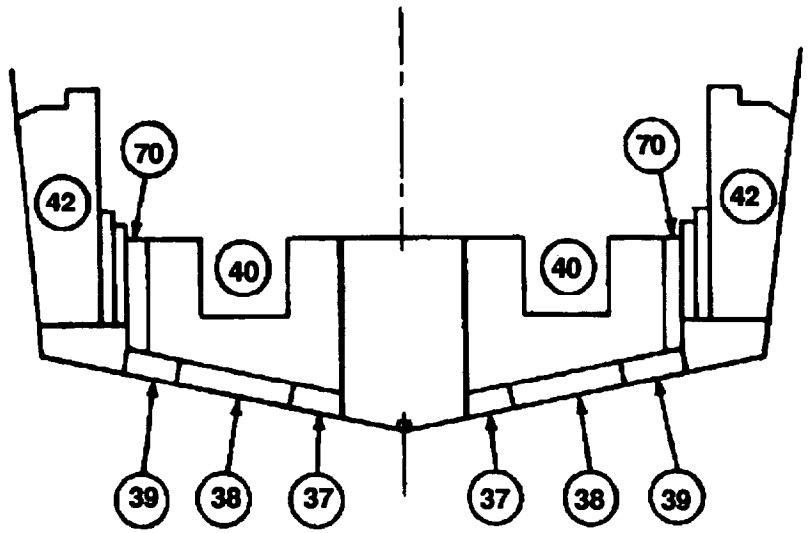

BLOCK PLACEMENT DIAGRAM CROSS-SECTION (MK 1)

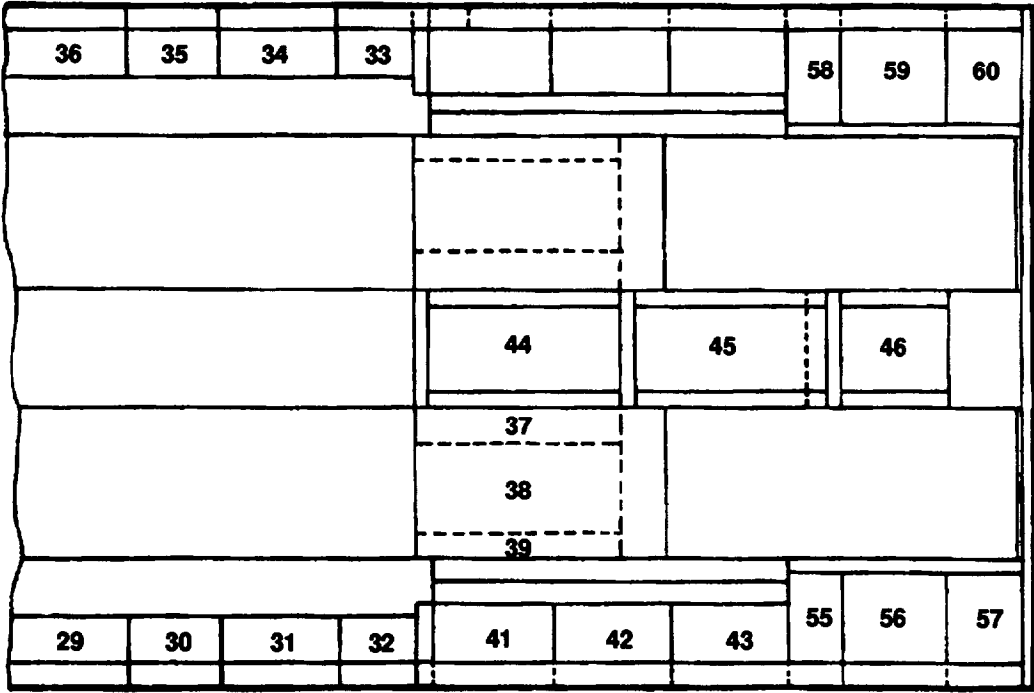

← BOW STERN →

BLOCK PLACEMENT DIAGRAM (MK 1)

REMOVE: (MK1 AFT COCKPIT AND DRIVE SHAFT COMPARTMENT BOTTOM - Block No. 37 thru 40, 49, 52 and 70)

1. Remove aft cockpit (refer to paragraph 3-27).
2. Remove drive shaft (refer to paragraph 3-141).

NOTE

Refer to block placement diagram and to block placement diagram cross-section for next steps.

3. Lift block number (40) out of position and set aside or discard as required.
4. Lift blocks number (52), (49) and (70) out of position and set aside or discard as required.
5. Lift blocks number (37), (38) and (39) out of position and set aside or discard as required.

INSTALL: (MK1 AFT COCKPIT AND DRIVE SHAFT COMPARTMENT BOTTOM - Block No. 37 thru 40, 49, 52 and 70)

NOTE

Refer to block placement diagram and to block placement diagram cross-section for steps 1 thru 3.

1. Install blocks number (37), (38) and (39).
2. Install block numbers (49), (52) and (70).
3. Install block number (40).
4. Install drive shaft (refer to paragraph 3-141).
5. Install aft cockpit (refer to paragraph 3-27).

REMOVE: (MK2 AFT COCKPIT AND DRIVE SHAFT COMPARTMENT BOTTOM - Blocks No. 49, 51, 52 and 71 through 78)

1. Remove aft cockpit (refer to paragraph 3-27).
2. Lift block number (51) out of position and place aside or discard as required.
3. Lift Mocks number (78), (71), and (72) out of position and place aside or discard as required.
4. Lift block number (77) out of position and place aside or discard as required.
5. Remove drive shaft (refer to paragraph 3-141).
6. Lift blocks number (76), (73), (49), (74), (75), and (52) out of position and place aside or discard as required.

INSTALL: (MK2 AFT COCKPIT AND DRIVE SHAFT COMPARTMENT BOTTOM - Blocks No. 49, 51, 52 and 71 through 78)

1. Install blocks number (52), (75), (74), (49), (73), and (76).
2. Install drive shaft (refer to paragraph 3-141).
3. Install blocks number (77).
4. Install blocks number (72), (71), (78), and (51).
5. Install aft cockpit (refer to paragraph 3-27).

3-153. MULTIMETER - SET-UP AND USE TO TEST ELECTRICAL SYSTEM

TOOLS: Small Flat Tip Screwdriver

PART/MATERIALS: Multimeter with probe wires

REFERENCE: TM 11-6625-203-12 (Army only), Operation and Maintenance of Multimeter AN/URM-105

NOTE

Each time a multimeter is used it must be checked for operation. All multimeters are tested and "zeroed" the same way.

In unit maintenance the prime use of multimeter is to test continuity or voltage.

TO "ZERO" MULTIMETER:

1. Selector switch off.
2. Check that needle is directly over zero on left side of scale.
3. Use mechanical adjusting screw to position needle over zero.

NOTE

One half of the multimeter has now been "zeroed" for correct scale readings.

4. Set selector switch on X1 OHMS.
5. Cross ends of probes.
6. Turn ohm adjustment knob until needle is over zero on right side of scale.

NOTE

- If any OHMS times (X) other than one is to be used, that section should be "zeroed" before using.

NOTE

- The multimeter scale is now adjusted for correct voltage and continuity reading.

USING MULTIMETER TO TEST ELECTRICAL SYSTEM:

CAUTION

- Multimeter can be damaged if the voltage scale is set too low for voltage being tested. Needle will indicate off scale to the left if black probe is connected to the positive (+) terminal.
 - To test for continuity, battery must be disconnected.
 - If you are not sure that no voltage is in a circuit, test for voltage first.
7. To test for continuity, set selector switch to OHMS.

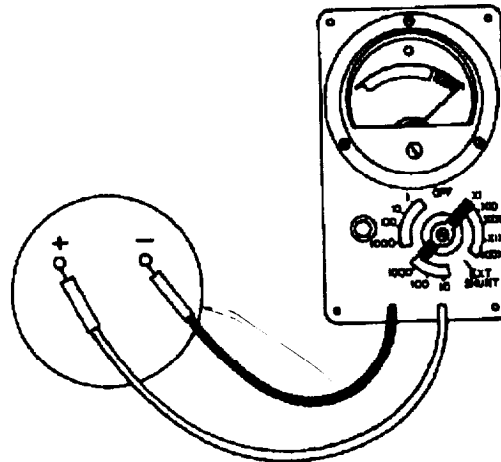

8. Put one probe on plus (+) terminal/contact and one on the negative (-)
9. Needle full right on scale, continuity through item is good.
10. Needle jumps back and forth, connection is bad or there is a short.
11. Needle does not move from left position on scale, item has an open circuit (no continuity).
12. To test electrical item or circuit for voltage, set multimeter to AC or DC volts position. (Set to a voltage higher than operating voltage.)
13. Connect batteries or source of voltage to the electrical system.

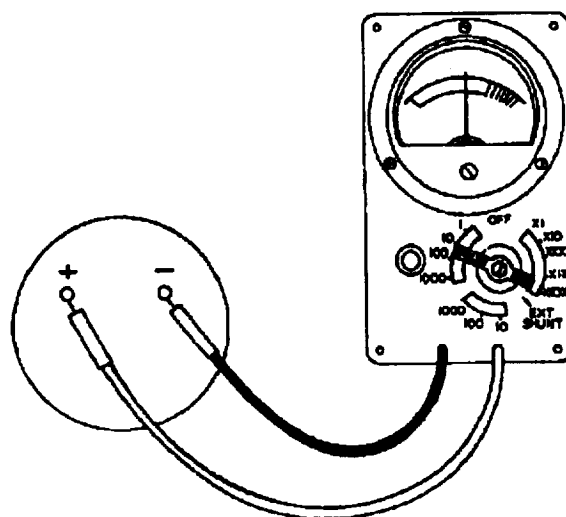

14. Connect black probe to negative (-) terminal and red probe to positive (+) terminal.
15. Read voltage on scale.

3-154. ACCESS HATCHES OPENING AND SECURING INSTRUCTIONS

Battery Hatch

Engine Hatch (Port and Starboard)

Hydrojet Hatch (Port and Starboard)

Control Console Access Hatch

BATTERY HATCH

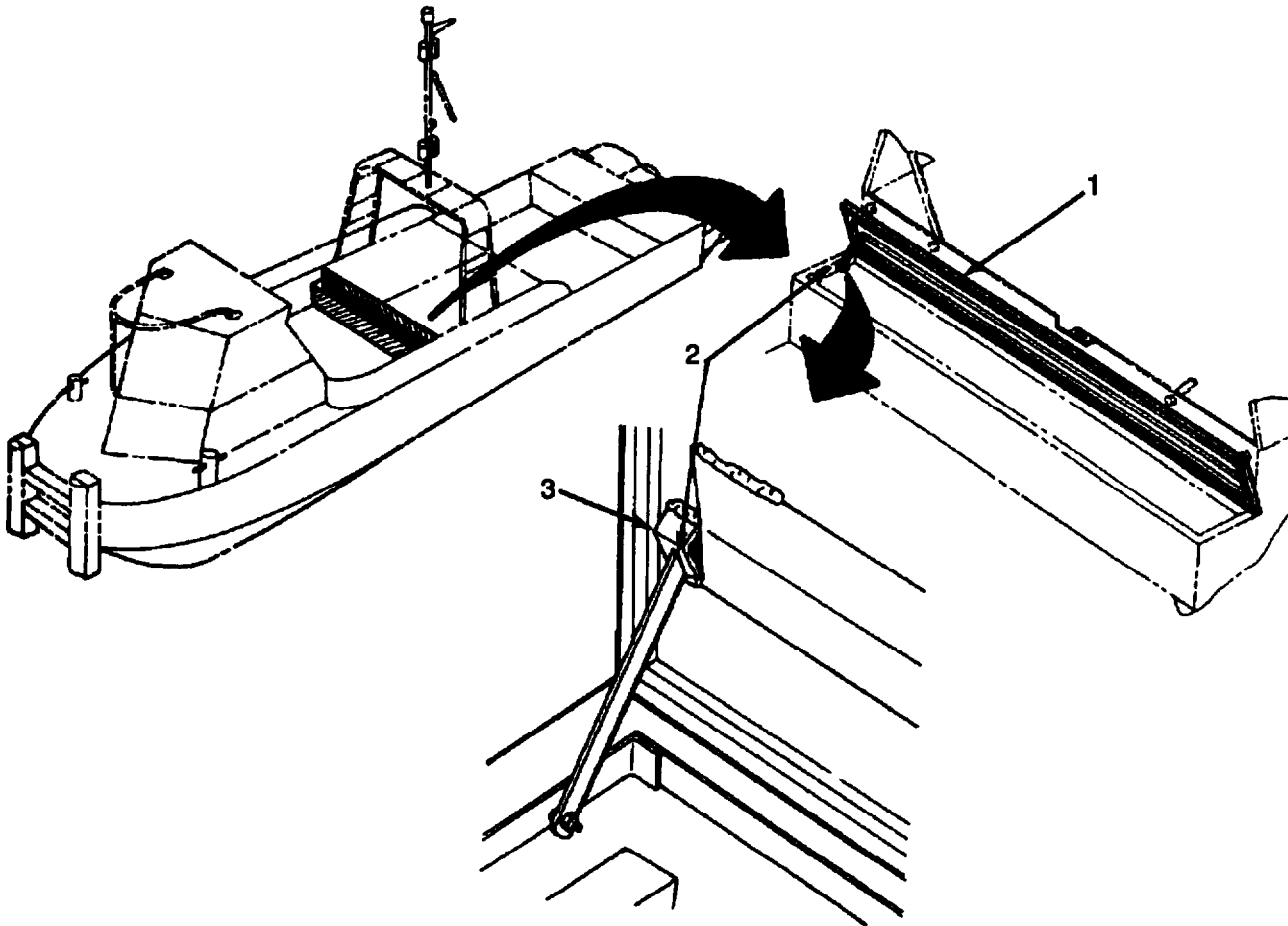

Opening and Securing:

1. Lift up front edge of battery hatch (1).
2. Swing securing brace (2) into grooved slot (3) on hatch (located on starboard side).

Closing:

1. Grasp front edge of battery hatch (1) and lift to open position to clear brace (2).
2. Remove securing brace (2) from grooved slot (3) and lower into stored position.
3. Close battery hatch by lowering to closed position.

ENGINE HATCHES (Port and Starboard)

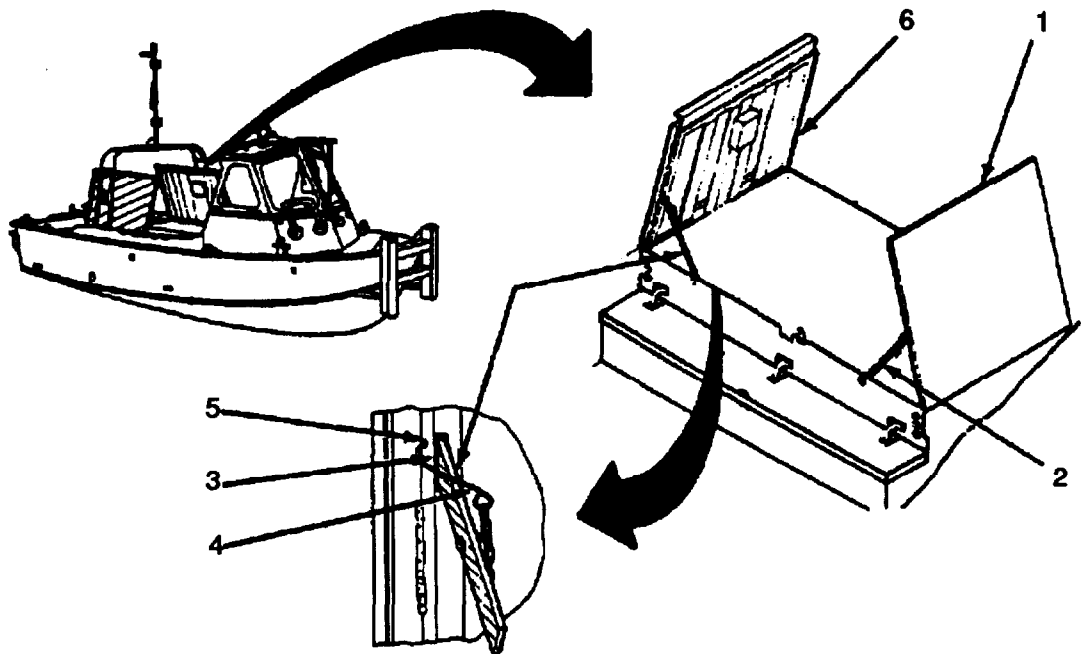

Opening and Securing:

1. Open port engine hatch (1).
2. Swing securing brace (2) upward into grooved slot (3) on hatch.
3. Place pin (4) through retaining hole (5).
4. Open starboard engine hatch (6).
5. Swing securing brace (2) upward into grooved slot (3) on hatch.
6. Place pin (4) thru retaining hole (5).

NOTE

When both engine hatches are open the starboard hatch must be closed first.

Closing:

1. Grasp edge of engine hatch [starboard (6) or port. (1)].
2. Remove pin (4) from retaining bolt (5) and securing brace (2). Push hatch (6 or 1) open to clear brace (2).
3. Remove securing brace (2) from grooved slot (3).
4. Swing securing brace (2) down into stored position.
5. Close engine hatch by lowering to closed position.

HYDROJET HATCH (Port and Starboard)

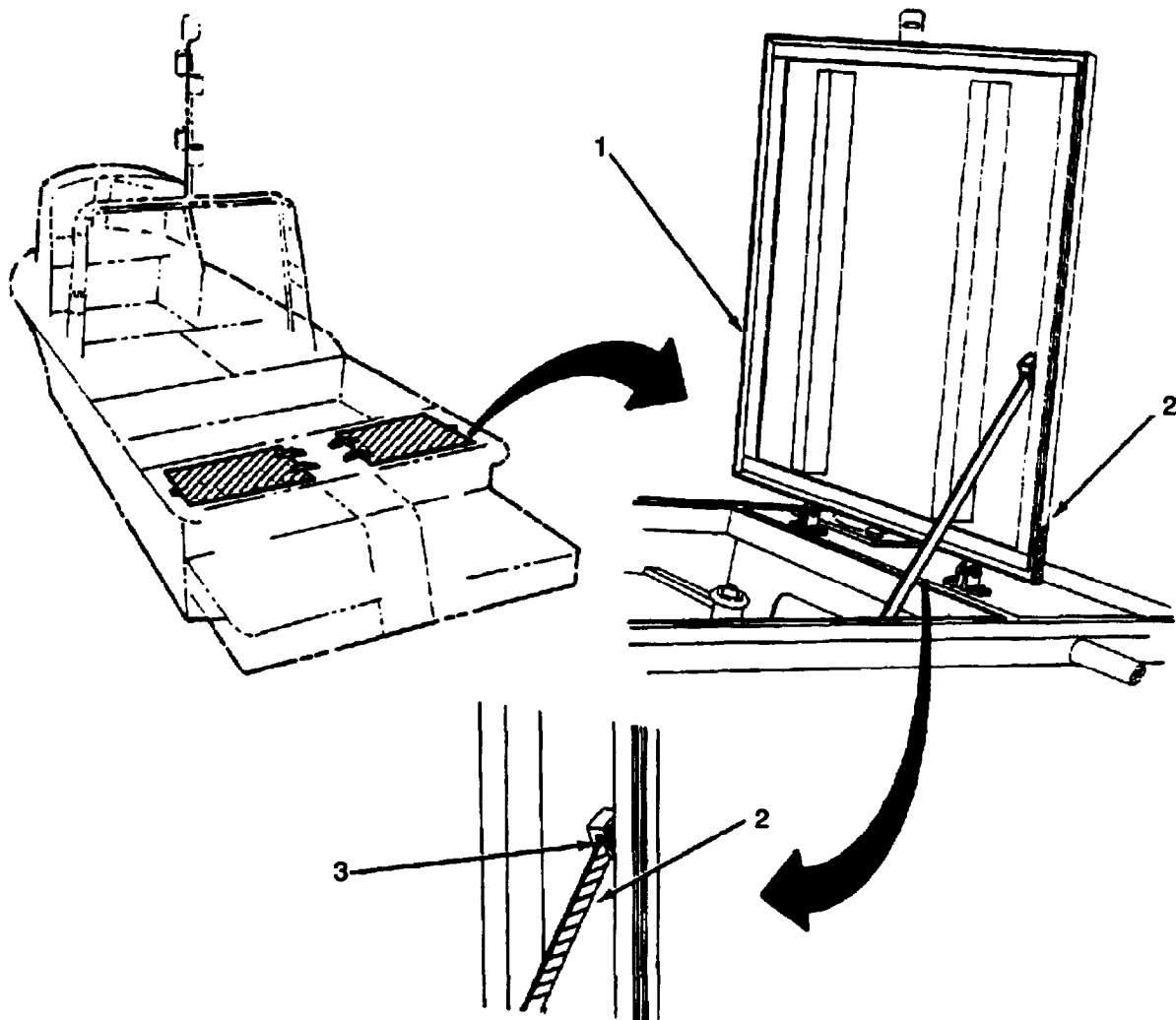

Opening and Securing:

1. Open hydrojet hatch (1) (port or starboard).
2. Swing securing brace (2) upward into grooved slot (3) on hatch.

Closing:

1. Grasp edge of hydrojet hatch (1) (port or starboard) and push open to clear securing brace (2).
2. Remove securing brace (2) from grooved slot (3) on hatch (1).
3. Swing securing brace (2) down into stored position.
4. Close hydrojet hatch (1) by lowering to closed position.

CONTROL CONSOLE ACCESS HATCH

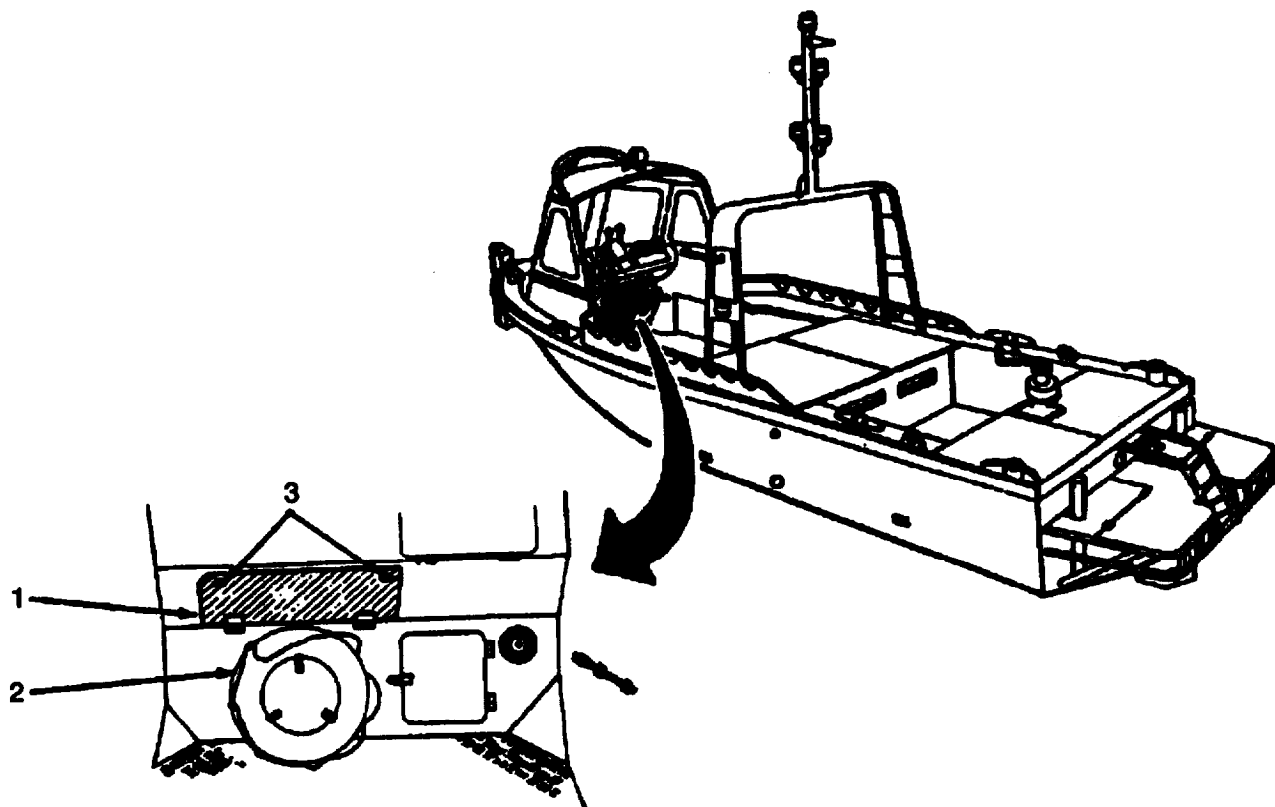

Opening:

1. Remove life ring (1) from mounting brackets and set aside.
2. Open access hatch (2) under control console by removing two wing nuts (3) and swinging hatch (2) down.

Closing:

1. Close access panel (2) and install two wing nuts (3). Tighten finger tight.
2. Remount life ring (1) in mounting brackets under control console.

3-155. OUT OF WATER ENGINE OPERATION

TOOLS: Flat Tip Screwdriver

MATERIALS: Engine Cooling Rose Assembly

NOTE

Procedure is same for both engines.

1. Open engine compartment hatch covers (refer to TM 5-1940-277-10) for MK1 or hydrojet compartment hatch covers for MK1.
2. Using screwdriver, loosen damp (1) on raw water intake hose (2) of strainer housing (3).
3. Pull raw water intake hose (2) loose from strainer housing (3).
4. Slip hose adapter (4) into raw water intake hose (2).
5. Using screwdriver, tighten damp (1).
6. Connect hose (5) to water supply.

NOTE

Next two steps must be performed together. Two persons required.

7. Start engine (refer to TM 5-1940-277-10).
8. Start flow of water through hose (5) and adapter (4) assembly.

NOTE

Continue to run water until engine is stopped.

9. Observe water temperature gage to make sure overheating does not occur.
10. Stop engine when check completed (refer to TM 5-1940-277-10).
11. Using screwdriver, loosen hose damp (1).
12. Disconnect raw water intake hose (2) from adapter (4).
13. Connect raw water intake hose (2) to strainer housing (4).
14. Using screwdriver, tighten hose damp (1).

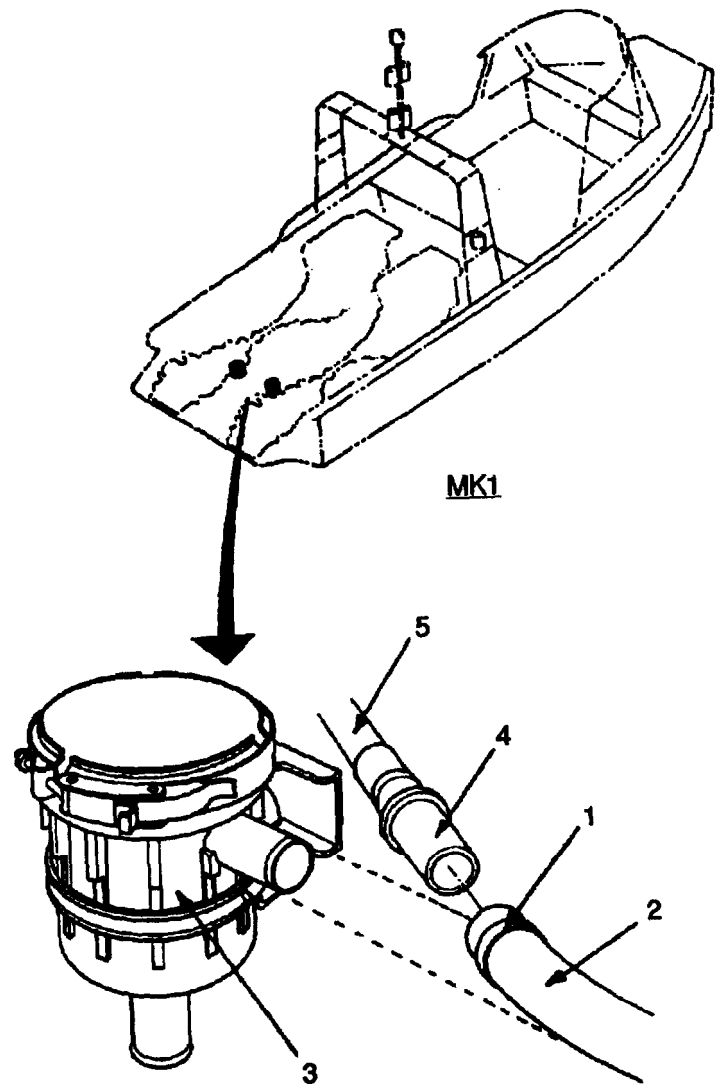

3-156. OUT OF WATER ENGINE OPERATION (MK2)

TOOLS: None

PARTS/MATERIALS: Water Hose Assembly

PERSONNEL: Two to three (one to operate engines and one to cool each engine from beneath boat).



Cooling engine during out of water operation requires personnel to work directly under boat. Take special precautions to ensure boat is securely supported.

NOTE

Procedure is same for both engines.

1. Start engine (refer to TM 5-1940-277-10).
2. Spray water on front and rear keel coolers (1) from beneath boat. Make sure spray hits both keel coolers.

NOTE

Continue to spray water until engine is stopped.

3. Observe water temperature gage to make sure overheating does not occur.
4. Stop engine when check is completed.

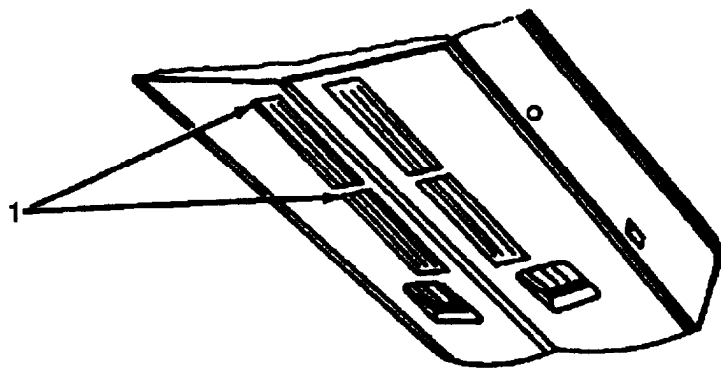
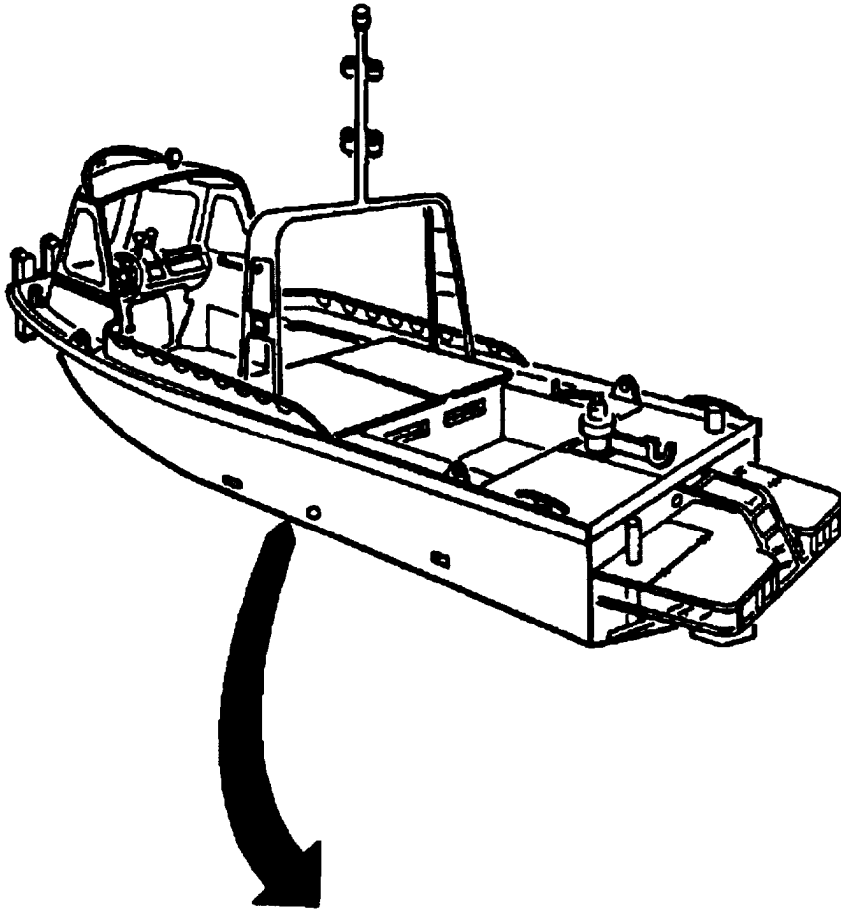

3-157. AFT CLEAT REPLACEMENT

TOOLS: 13/16 inch Socket
Ratchet

PARTS/MATERIALS: Aft Cleats

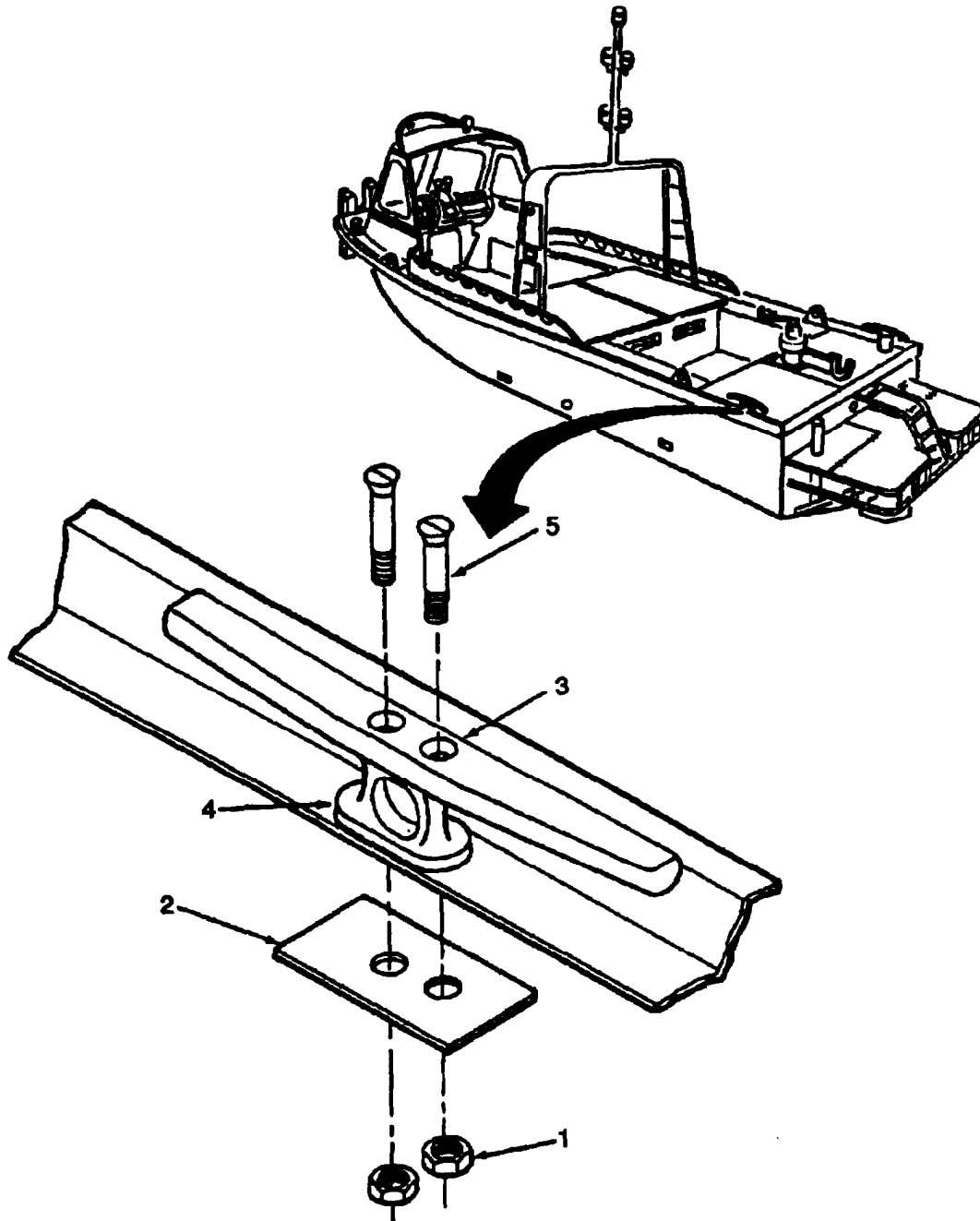

REMOVE:

NOTE

Procedure for replacement of both starboard and port aft cleats are the same.

1. Remove aft cockpit (refer to paragraph 3-27).
2. Lift two wedge blocks out of position and place aside (refer to paragraph 3-152).
3. Tilt blocks (55) and (56) toward boat centerline, lift out, and place aside (refer to paragraph 3-152).

NOTE

Buoyancy blocks (58) and (59) are removed for starboard aft cleat.

4. Using 13/16 inch socket and ratchet, remove two nuts (1), two washers (2), and metal plate (3) from under aft cleat (4).
5. Remove two screws (6) from top of aft cleat (4).
6. Lift aft cleat (4) from gunwale (5).

INSTALL:

1. Insert aft cleat (4) into gunwale (5).
2. Install two screws (6) in top of aft cleat.
3. Install metal plate (3), two washers (2), and two nuts (1) and tighten using 13/16 inch socket and ratchet.
4. Replace buoyancy blocks and wedge blocks (refer to paragraph 3-152).
5. Install aft cockpit (refer to paragraph 3-27).

3-158. BOAT HOOK HOLDER REPLACEMENT INSTRUCTIONS.

TOOLS: Flat Tip Screwdriver
Adjustable Wrench

PARTS/MATERIALS: Boat Hook Holders

NOTE

Procedure for replacement of both boat hook holders are the same.

REMOVE:

1. Open battery hatch (refer to paragraph 3-154).
2. Remove nuts (1), washers (2) and screws (3) to remove boat hook holder (4).

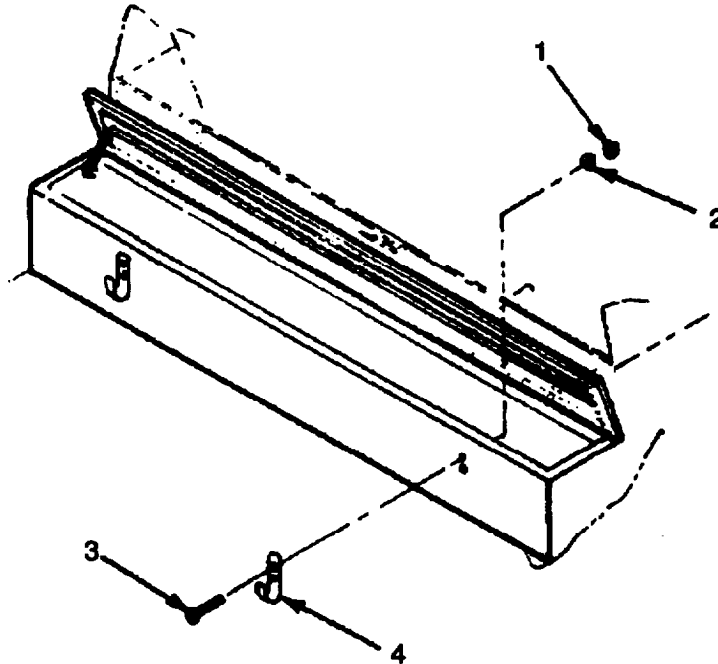

INSTALL:

1. Install screws (3) into boat hook holder (4).
2. Insert screws into mounting holes inside of battery box
3. Install washers (2) and nuts (1).
4. Close battery hatch (refer to paragraph 3-154).

APPENDIX A

REFERENCES

A-1. LUBRICATION.

C9100-IL Identification List for Fuels, Lubricants, Oils and Waxes
LO 5-1940-277-12/ Lubrication Order
LI 1940-12

A-2. MAINTENANCE.

TB 750-651 K Use of Antifreeze Solutions and Cleaning Compounds in Cooling System
DA Pam 738-750 The Army Maintenance Management System (TAMMS)
TM 5-1940-277-10 Operator's Manual for Boat, Bridge Erection, Twin Jet, Aluminum Hull, Models USCSBMK1 and USCSBMK2
TM 5-1940-277-20P Organizational Repair Parts and Special Tools List for Boat, Bridge Erection, Twin Jet, Aluminum Hull, Models USCSBMK1 and USCSBMK2
TM 5-6140-200-14 Operation and Organizational, Field, and Depot Maintenance: Storage Batteries, Lead-Acid Type
TM 5-5420-209-12 Operator and Organizational Maintenance Manual for Ribbon Bridge
TM 9-247 Materials Used for Cleaning, Preserving, Abrading and Cementing Ordnance Material
TM 9-237 Operator's Manual for Welding Theory and Application
TM 9-214 Inspection, Care, and Maintenance of Anti-friction Bearings

A-3. SHIPMENT AND STORAGE.

TM 740-90-1 Administrative Storage of Equipment
TB 55-46-1 Standard Characteristics (Dimensions, Weight, and Cube) for Transportability of Military Vehicles and Other Outsize/Overweight Equipment

A-4. DESTRUCTION TO PREVENT ENEMY USE.

TM 750-244-3 Procedures for Destruction of Equipment to Prevent Enemy Use

A-5. Forms

DA Form 2028 Recommended Changes to Publications and Blank Forms
DA Form 2028-2 Recommended Changes to Equipment Technical Publications
DA Form 2408-S Equipment Control Record
MCO 1650.17 Marine Corps Military Incentive Awards Program
MCO 4855.10 Quality Deficiency Report for MC Users
NAVMC Form 10772 Recommended Changes to Technical Publications
SF368 Quality Deficiency Report

A-6. MISCELLANEOUS.

FM 21-11 First Aid for Soldiers
TM 4700-15/1 Equipment Record Procedures

APPENDIX B

MAINTENANCE ALLOCATION CHART (MAC)

Section I. INTRODUCTION

B-1. GENERAL.

- a. This section provides a general explanation of all maintenance and repair functions authorized at various maintenance categories.
- b. The Maintenance Allocation Chart (MAC) in Section II designates overall authority and responsibility for the performance of maintenance functions on the identified end item or component. The application of the maintenance functions to the end item or component will be consistent with the capacities and capabilities of the designated maintenance categories.
- c. Section III lists the tools and test equipment (both special tools and common tool sets) required for each maintenance function as referenced from Section II.
- d. Section IV contains supplemental instructions and explanatory notes for a particular maintenance function.

B-2. MAINTENANCE FUNCTIONS. Maintenance functions will be limited to and defined as follows:

- a. **Inspect.** To determine the serviceability of an item by comparing its physical, mechanical, and/or electrical characteristics with established standards through examination (e.g., by sight, sound, or feel).
- b. **Test.** To verify serviceability by measuring the mechanical, pneumatic, hydraulic, or electrical characteristics of an item and comparing those characteristics with prescribed standards.
- c. **Service.** Operations required periodically to keep an item in proper operating condition, i.e., to dean (includes decontaminate, when required), to preserve, to drain, to paint, or to replenish fuel, lubricants, chemical fluids, or gases.
- d. **Adjust.** To maintain or regulate, within prescribed limits, by bringing into proper or exact position, or by setting the operating characteristics to specified parameters.
- e. **Aline.** To adjust specified variable elements of an item to bring about optimum or desired performance.
- f. **Calibrate.** To determine and cause corrections to be made or to be adjusted on instruments or test, measuring, and diagnostic equipments used in precision measurement. Consists of comparisons of two instruments, one of which is a certified standard of known accuracy, to detect and adjust any discrepancy in the accuracy of the instrument being compared.
- g. **Remove/Install.** To remove and install the same item when required to perform service or other maintenance functions. Install may be the act of emplacing, seating, or fixing into position a spare, repair part, or module (component or assembly) in a manner to allow the proper functioning of an equipment or system.
- h. **Replace.** To remove an unserviceable item and install a serviceable counterpart in its place. "Replace" is authorized by the MAC and is shown as the third position code of the SMR code.

i. Repair. The application of maintenance services¹ including fault location/troubleshooting², removal/installation, end disassembly/assembly³ procedures, and maintenance actions⁴ to identify troubles and restore serviceability to an item by correcting specific damage, fault, malfunction, or failure in a part, subassembly, module (component or assembly), end item, or system.

j. Overhaul. That maintenance effort (service/action) prescribed to restore an item to a completely serviceable/operational condition as required by maintenance standards in appropriate technical publications (i.e., DMWR). Overhaul is normally the highest degree of maintenance performed by the Army. Overhaul does not normally return an item to like new condition.

k. Rebuild. Consists of those services/actions necessary for the restoration of unserviceable equipment to a like new condition in accordance with original manufacturing standards. Rebuild is the highest degree of materiel maintenance applied to Army equipment. The rebuild operation includes the act of returning to zero those age measurements (hours/miles, etc.) considered in classifying Army equipment/components.

B-3. EXPLANATION OF COLUMNS IN THE MAC, Section II.

a. Column 1, Group Number. Column 1 lists functional group code numbers, the purpose of which is to identify maintenance significant components, assemblies, subassemblies, and modules with the next higher assembly. End item group number shall be "00".

b. Column 2, Component/Assembly. Column 2 contains the names of components, assemblies, subassemblies, and modules for which maintenance is authorized.

c. Column 3, Maintenance Function. Column 3 lists the functions to be performed on the item listed in Column 2. (For detailed explanation of these functions, see paragraph B-2.)

d. Column 4, Maintenance Category. Column 4 specifies, by the listing of a work time figure in the appropriate s&column(s), the category of maintenance authorized to perform the function listed in Column 3. This figure represents the active time required to perform that maintenance function at the indicated category of maintenance. If the number or complexity of the tasks within the listed maintenance function vary at different maintenance categories, appropriate work time figures will be shown for each category. The work time figure represents the average time required to restore an item (assembly, subassembly, component, module, end item, or system) to a serviceable condition under typical field operating conditions. This time includes preparation time (including any necessary disassembly/assembly time), troubleshooting/fault location time, and quality assurance/quality control time in addition to the time required to perform the specific tasks identified for the maintenance functions authorized in the maintenance allocation chart. The symbol designations for the various maintenance categories are as follows:

C Operator or crew maintenance
O Unit maintenance
F Direct support maintenance
H General support maintenance
D Depot maintenance

e. Column 5, Tools and Equipment. Column 5 specifies, by code, those common tool sets (not individual tools) and special tools, TMDE, and support equipment required to perform the designated function.

f. Column 6, Remarks. This column shall, when applicable, contain a letter code, in alphabetic order, which shall be keyed to the remarks contained in Section IV.

¹Services - Inspect, test, service, adjust, align, calibrate, and/or replace.

²Fault location/troubleshooting - The process of investigating and detecting the cause of equipment malfunctioning; the act of isolating a fault within a system or unit under test (UUT).

³Disassembly/assembly - The step-by-step breakdown (taking apart) of a spare/functional group coded item to the level of its least component, that is assigned an SMR code for the level of maintenance under consideration (i.e., identified as maintenance significant-)

⁴Actions - Welding, grinding, riveting, straightening, facing, machining, and/or resurfacing.

B-4. EXPLANATION OF COLUMNS IN TOOL AND TEST EQUIPMENT REQUIREMENTS, Section III.

- a. Column 1, Reference Code. The tool and test equipment reference code correlates with a code used in the MAC, Section II, Column 5.
- b. Column 2, Maintenance Category. The lowest category of maintenance authorized to use the tool or test equipment.
- c. Column 3, Nomenclature. Name or identification of the tool or test equipment.
- d. Column 4, National Stock Number. The national stock number of the tool or test equipment.
- e. Column 5, Tool Number. The manufacturer's part number.

B-S. EXPLANATION OF COLUMNS IN REMARKS, Section IV.

- a. Column 1, Reference Code. The code recoded in Section II Column 6.
- b. Column 2, Remarks. This column lists information pertinent to the maintenance function being performed as indicated in the MAC, Section II.

**Section II. MAINTENANCE ALLOCATION CHART
 FOR
 BOAT, BRIDGE ERECTION, TWIN JET, ALUMINUM HULL,**

(1) Group Number	(2) Component/Assembly	(3) Maintenance Function	(4) Maintenance Level					(5) Tools and Equipment	(6) Remarks
			C	O	F	H	D		
01	MAST	Inspect Replace	0 . 1	0.2				1,2	
0 2	CAB Cab Assembly	Inspect Repair Replace	0.1	2.0 0.2				1,2	A
	Windshield Wipers	Inspect Replace	0.1	0.1				2	
	Windshield Wiper Motor	Inspect Repair Replace	0.1		1.0			1,2 1,2	
	Windshield Wiper Drive Unit	Inspect Repair Replace	0.1	0.5 1.5				2,6 2,6	
03	TOWING ATTACH- MENTS AND ACCES- SORY ITEMS								
	Capstan	Inspect Service Replace	0.1	0.5 0.2				2,36 2,36	
	Tow Hook Assembly	Inspect Service Repair Replace	0.1	0.5 1.0 0.2				1 1 1	
	Pushknees	Inspect Repair Replace	0.1	1.0 0.4				2,4 2	A I
04	HATCHES, HINGES, AND SUPPORT BRACES								
	Battery Hatch Cover, Hinges, and Support Brace	Inspect Replace	0.1	0.8				1	
	Engine Hatch Cover, Hinges, Support Brace, Foam Backing and Support Caps	Inspect Replace Repair	0.1	0.8 1.0				1	
	Hydrojet Hatch Cover, Hinges, and Support Brace	Inspect Replace	0.1	0.8				1	

**Section II. MAINTENANCE ALLOCATION CHART
FOR
BOAT, BRIDGE ERECTION, TWIN JET, ALUMINUM HULL,
MODELS USCSBMK1 AND USCSBMK2**

(1) Group Number	(2) Component/Assembly	(3) Maintenance Function	(4) Maintenance Level					(5) Tools and Equipment	(6) Remarks	
			C	O	F	H	D			
0 4 (cont)	Aft Cockpit	Inspect Replace	0.1	0.4				1		
	Steering Unit Hatch Cover and Hinges	Inspect Replace	0.1	0.8				1		
0 5	SCUPPER DRAINS	Inspect Service Replace	0.1	0.3 0.4				1,2,13 1,2,13		
0 6	CONTROLS									
	Control Head Assemblies									
	Scoop	Inspect Repair Replace	0.1	0.5 1.6				2,5 2,5		
	Engine & Transmission	Inspect Repair Replace	0.1	0.5 0.8				2 2		
	Control Cables and Linkages (Scoop, Transmission, & Engine)	Inspect Adjust Replace	0.1	0.2 0.5				2 2,5		
	Steering Cable	Inspect Replace	0.1	0.5				1,2		
	Steering Wheel Assembly	Inspect Repair Replace	0.1	1.0 0.5				1,2 1,2		
	Tie Rod	Inspect Adjust Replace		0.1 0.3 0.5				1,2 1,2		
	0 7	INSTRUMENT PANEL								
		Gage Lights	Inspect Replace	0.1	0.1				1,2,6	
Gages		Inspect Replace	0.1	0.7				1,2,6		
Warning Lights		Inspect Replace	0.1	0.1				1,2,6		
Gage Light Dimmer Switch		Inspect Replace	0.1	0.7						
Switches		Inspect Test Replace	0.1	0.1 0.7				2 1,2		

**Section II. MAINTENANCE ALLOCATION CHART
 FOR
 BOAT, BRIDGE ERECTION, TWIN JET, ALUMINUM HULL,
 MODELS USCSBMK1 AND USCSBMK2**

(1) Group Number	(2) Component/Assembly	(3) Maintenance Function	(4) Maintenance Level					(5) Tools and Equipment	(6) Remarks
			C	O	F	H	D		
07 (cont)	Switches Panels, Circuit Breaker, and Junction Boxes	Inspect Replace	0.1	1.5				1,2,6	
	Engine Alarm Mute Switch	Inspect Replace	0.1	0.2					
	Horn	Inspect Replace	0.1	0.2				1,5	
	Engine Audible Alarm	Inspect Replace	0.1	0.5					
08	FUEL SYSTEM								
	Fuel Tank	Inspect Replace	0.1		5.0			12	
	Fuel Tubing, Engine shutoff valves	Inspect Replace	0.1	0.2				2	
	Engine Shutoff Valve Diaphragm	Replace		0.6				2	B
	Fuel Master Shutoff Valve	Inspect Replace	0.1	1.0				1,2,5	
	Fuel Sedimenter (Fuel -Water Separator)	Inspect Service Replace	0.1 0.1 0.2					1 2,6	
	Fuel Fitter	Inspect Replace	0.1	0.2				2	
	Fuel Lift Pump Assembly	Inspect Replace	0.1	1.0				2	
	09	EXHAUST SYSTEM							
Exhaust Pipes & Flex- ible Bellows		Inspect Replace	0.1	2.0				1	
10	COOLING SYSTEM								
	Piping, Hoses, and Fittings	Inspect Replace	0.1	0.2				2	
	Primary Cooling Sys- tem Water Pump	Inspect Replace	0.1	0.4				2	
	Header Tank/Heat Exchanger	Inspect Repair Replace	0.1	0.5 1.0				1,2 1,2	I
	Thermostat	Replace		0.4				2,5	

Section II. MAINTENANCE ALLOCATION CHART

BOAT, BRIDGE ERECTION, TWIN JET, ALUMINUM HULL,
MODELS USCSBMK1 AND USCSBMK2

(1) Group Number	(2) Component/Assembly	(3) Maintenance Function	(4) Maintenance Level					(5) Tools and Equipment	(6) Remarks
			C	O	F	H	D		
10 (cont)	Engine Oil Cooler	Inspect	0.1						
		Replace		1.0				2,5	
		Repair		0.5				2,5	
	Oil Filter Element	Inspect	0.1						
		Replace		0.3				2	
	Keel Coolers (MK2)	Inspect	0.1						J
		Repair		0.5				5,35	J,K
		Replace		1.0				2,5,35	J
	Remote Coolers (MK1)	Inspect	0.1						I
		Repair		0.5				2,5	I
Replace			0.3				2,5	I	
Secondary Cooling System Water Pump	Inspect		0.1						
	Repair		0.5				1,2		
	Replace		1.0				1,2		
Intercooler	Inspect	0.1							
	Repair		0.5				2		
	Replace		1.0				2		
Transmission Oil Cooler	Inspect		0.1					J	
	Repair		0.5				2	J	
	Replace		1.0				2	J	
Intake Strainer (MK1)	Inspect	0.1						I	
	Replace		0.1					I	
Drain Down Valve	Inspect	0.1						I	
	Replace				0.7		2	I	
11	ELECTRICAL SYSTEM								
Batteries and Cables	Inspect	0.2							
	Test		0.2				2,6		
	Service Replace	0.5	0.5				2,6		
Alternator	Test		0.5						
	Replace		1.0				2		
	Repair			1.5			12		
Voltage Regular	Test		0.5						
	Replace			1.5					
Anchor Light Assembly	Inspect	0.1							
	Replace		0.5				1		
Towing, Steaming, and Navigation Light Assembly	Inspect	0.1							
	Replace		0.5				1		
	Repair		0.1					L	

**Section II. MAINTENANCE ALLOCATION CHART
 FOR
 BOAT, BRIDGE ERECTION, TWIN JET, ALUMINUM HULL,
 MODELS USCSBMK1 AND USCSBMK2**

(1) Group Number	(2) Component/Assembly	(3) Maintenance Function	(4) Maintenance Level					(5) Tools and Equipment	(6) Remarks
			C	O	F	H	D		
11 (cont)	Searchlight	Inspect Replace	0.1	0.1				5,6	
	Inspection Light	Inspect Replace	0.1	0.2				1	
	Map Light	Inspect Replace	0.1	0.2				1	
	Master Switch	Replace		1.0				2,4	
	Sending Units (Water Temperature and Oil Pressure)	Replace		0.3				2,5,6	
	Fuel Level Sending Unit	Replace		1.0				2,5,6	
	Tachometer Sending Unit Assembly	Inspect		0.2					
		Replace		0.3				2,6	
		Repair		0.4				2,6	
	Interconnection Loom (Engine Wiring	Inspect		0.2		2.5			
		Replace				0.5		2,5	
		Repair						2,5,12	
	Engine Wiring Interconnect Harness	Replace				6.0		2	
		Repair				0.5			
	Mast Loom (Mast Wiring Harness)	Inspect		0.1					
		Repair			0.4			2	
		Replace				1.5		2	
	Emergency Link solenoid, switches	Test			0.5			2	
		Replace			0.6			2,4,6	
					0.5			1	
Thermostat Unit	Inspect			0.6			2		
	Test			0.6			2		
	Replace			0.6			2		
Electrical Leads and Cables	Inspect			0.5					
	Replace			1.5			2		
Connectors	Inspect			0.1					
	Replace			1.0			2		
	Repair				4.0			L	
Blocking Diode	Test			0.2			2,4,5,33,34		
	Replace			0.3			2,4		
Control Box	Test			1.0			2,4,6		
	Replace				2.0		2,4,6		
	Repair				4.0			L	
Fast Fuse	Replace		0.5				2		

**Section II. MAINTENANCE ALLOCATION CHART
FOR
BOAT, BRIDGE ERECTION, TWIN JET, ALUMINUM HULL,
MODELS USCSBMK1 AND USCSBMK2**

(1) Group Number	(2) Component/Assembly	(3) Maintenance Function	(4) Maintenance Level					(5) Tools and Equipment	(6) Remarks
			C	O	F	H	D		
11 (cont)	Hour Meter	Test Replace	0.1	0.3					
12	ENGINE								
	Mounts and Brackets	Inspect Replace	0.1		0.5			2,4,6,12	
	Engine Assembly	Inspect Test Service Replace Repair Overhaul	0.1	*	1.5 6.5	*		2,31 2,4,6,12 4,5,6,7,8, 10,11,12	C D E
	V-Belt	Inspect Adjust Replace	0.1 0.1	0.2					
	Starter Motor	Test Replace Repair		0.5 0.8	2.0			2 2 12	
	Exhaust Manifold	Inspect Replace	0.1	3.0				2,6	
	Turbocharger	Inspect Replace Repair	0.1	1.0	2.0			2,5 5,15	F
	Injector Pump	Inspect Replace Repair	0.1		1.5		*	2 22 thru 30	
	Boost Control Unit, Injector Pump	Replace Service Repair		0.5			*		
	Injector Lines and Fittings	Inspect Replace	0.1	1.0				2	
	Rocker Arms, Shaft and Push Rods	Inspect Replace		0.2 1.5				1 2	
	Cam Follower	Inspect Replace				0.5 3.0		12 12	
	Injectors	Test Replace Repair		1.0	0.2 2.5			8 2 8,12,18	F F
	Cylinders Head Assembly	Inspect Repair Replace			0.5 8.5 5.0			12 12 12	

**Section II. MAINTENANCE ALLOCATION CHART
 FOR
 BOAT, BRIDGE ERECTION, TWIN JET, ALUMINUM HULL,
 MODELS USCSBMK1 AND USCSBMK2**

(1) Group Number	(2) Component/Assembly	(3) Maintenance Function	(4) Maintenance Level					(5) Tools and Equipment	(6) Remarks
			C	O	F	H	D		
12 (cont)	Valves	Adjust		1.0				2	
	Valve Springs	Replace			2.0			12	
	Crankshaft Pulley	Inspect Replace	0.1	1.0				2	
	Oil Pump	Replace				4.0		12	
	Piston and Connect- ing Rod Assembly	Inspect				0.5		12	F
		Repair				14.0		12	
		Replace				8.0		12	
	Cylinder Liner	Inspect				1.5			
		Replace				12.0		12,10	
	Main Bearings	Inspect				1.0			
		Replace				8.0		12	
	Crankshaft	Inspect				1.5			
		Replace				6.0		12,21	
	Camshaft	Inspect				1.0			
		Replace				6.0		12	
	Camshaft Bearings	Inspect				1.0			
		Replace				8.0		12,19,20	
	Engine Block	Inspect				1.0			
		Replace				8.0		12	
	Oil Sump (Pan)	Inspect			0.5				
Replace				7.0			12		
Flywheel and Housing	Inspect		0.5						
	Replace			3.0			1		
Sump Pump Assembly	Inspect	0.1							
	Replace		0.4				1		
Engine Breather Water Trap Assembly	Inspect	0.1							
	Service Replace	0.1	0.3				2		
Air filter Assembly, Cover, Filter Element, and Silencer	Inspect	0.1					1		
	Service Replace		0.5 0.2				1		
13	TRANSMISSION								
	Oil Strainer Assembly	Inspect		0.1				2	G
		Service		1.0				2	
		Replace		1.0				2	
Lines and Fittings	Inspect	0.1	1.2					G	
	Replace		0.4				1		

**Section II. MAINTENANCE ALLOCATION CHART
FOR
BOAT, BRIDGE ERECTION, TWIN JET, ALUMINUM HULL,
MODELS USCSBMK1 AND USCSBMK2**

(1) Group Number	(2) Component/Assembly	(3) Maintenance Function	(4) Maintenance Level					(5) Tools and Equipment	(6) Remarks	
			C	O	F	H	D			
13 (cont)	Valve and Spring Assembly	Replace			3.0			12		
	Oil Pump	Replace			2.0			12		
	Transmission	Inspect	0.4			1.0	4.0		12	9,12,15,16 17
		Replace Repair								
	Overhaul					*				
14	HYDROJET UNIT									
	Hydrojet Assembly, Two-Stage	Inspect	0.1 0.2			10.0	2.0	*	4,5,6,7,11	4,5,6,7,11
		Service								
		Replace								
		Repair								
	Steering Assembly (Scoop Assemblies)	Overhaul								
		Inspect	0.1			2.0		*	2,6	4,5,6,7,12
		Adjust								
	Replace Overhaul									
	Brush	Replace		0.5					5,6	
	Reverse Balance Lever	Replace			0.5				5,6	
	Scoop Control Rods	Replace			0.8				5,6	
	Scoop	Replace			2.0				4,5,6,11	
Rotary Control Assembly	Inspect	0.1			2.0			1,4,5,6,7	1,4,5	
	Repair									
	Replace									
Anode	Inspect		0.1							
	Replace		0.3					2,4		
15	DRIVE SHAFT ASSEMBLY									
	Drive Shaft Assembly	Inspect	0.1						2,6,33	
		Service		0.5				2		
		Repair		3.5				2,5,6		
		Replace		2.0				2,5,6		
16	BILGE PUMP									
	Electric Pump Assembly	Inspect	0.1						2,5,6	
		Replace		1.0				2,5,6,14		
Repair		1.5								

**Section II. MAINTENANCE ALLOCATION CHART
 FOR
 BOAT, BRIDGE ERECTION, TWIN JET, ALUMINUM HULL,
 MODELS USCSBMK1 AND USCSBMK2**

(1) Group Number	(2) Component/Assembly	(3) Maintenance Function	(4) Maintenance Level					(5) Tools and Equipment	(6) Remarks
			C	O	F	H	D		
16 (cont)	Hand Pump Assembly	Inspect Replace Repair	0.1	1.0 1.5				2,6 2,6	
17	FIRE EXTINGUISHER								
	Automatic Fire Extinguisher	Inspect Replace	0.3	0.5				1	
	Hand-portable Fire Extinguisher	Inspect Replace	0.1	0.1					
18	HULL								
	Anodes	Inspect Replace		0.1 0.5				4,6	H
	Fendering (Rubber Rub Rail)	Inspect Replace		0.1 2.0				2	
	Buoyancy Blocks	Inspect Replace		0.2 0.3					
	Hull Assembly	Inspect Repair Overhaul	0.2		4.0		*	3,11	A
	Aft Cleats	Inspect Replace	0.1	0.8				1,6	
	Boat Hook Holder	Inspect Replace	0.1	0.8				1,6	
*DENOTES: O,H - Operational General Support Maintenance time for individual functions are as noted under maintenance time for the individual subassembly. D - Depot Support Maintenance time to perform overhaul will be shown in the - Depot Maintenance Work Requirements (DMWR).									

**Section III. TOOL AND TEST EQUIPMENT REQUIREMENTS
FOR
BOAT, BRIDGE ERECTION, TWIN JET, ALUMINUM HULL,
MODELS USCSBMK1 AND USCSBMK2**

TOOL OR EQUIPMENT REF CODE	MAINTENANCE CATEGORY	NOMENCLATURE	NATIONAL/ NATO STOCK NUMBER	TOOL NUMBER
1	O	Toot Kit, General Mechanic's Automotive	5180-00-177-7033	
2	O	Shop Equipment Contract Maint. Trk. Mtd	4940-01-016-2216	
3	F	Welding Set Arc, Inert Gas Shielded	3431-00-079-0483	AIRCO Inc. FSCM 00741 PN 235-0685
4	O	Socket Set, Socket Wrench, 23 piece set 10 to 32 mm, 1/2" sq drive, 12 pt. standard reach, mtd. on socket rail	5120-01-116-6047	FSCM 55719 PN323SWMY
5	O	Wrench Set, Open End, Fixed, dble-hd type 15 deg. angle, 11 pc. set w/kit bag	5120-01-115-1148	FSCM 55719 ON VOM811K
6	O	Wrench Set, Combination Box/Open 19 PC, 10 to 32 mm	5120-01-119-0010	FSCM 55719 PN OEXM 719K
7	O	Key Set, Socket Head Screw hex, 14 keys hex type, L-shaped 2 to 19 mm w/bag	5120-01-046-5979	FSCM 55719 PN AWM 140CK
8	F	Test Set, Diesel Injector	4910-00-31 7-8265	
9	H	Stand, Maintenance Automotive Engine (MIL-S-45004)	4910-00-529-8387	
10	H	Remover and Installer; Engine Cylinder Liner	4910-01-134-7323	FA 067 FSCM U3120
11	F	Shop Equipment, Automotive Maintenance and Repair, Field Maintenance, Basic Less Power	4910-00-754-0705	
12	F	Shop Equipment, Fuel and Electrical System Engine, Field Maintenance, Basic Less Power	4910-00-754-0714	
13	O	Scupper Drain Tool		Local Fabrication.
14	O	Bilge Pump Impeller Tool		Local Fabrication
15	H	Cluth and Planetary Assembly Fixture		Local Fabrication
16	H	Pump Oil Seal Sleeve		Local Fabrication
17	H	Rearing Assembly Tool		Local Fabrication
18	F	Socket, Nossle Nut; injector	5120-01-046-7300	FSCM 55719 PN SM19
19	H	Remove and Installer Camshaft Bearing Main Tool	5120-01-122-2954	FSCM K0598 PN 21-022

**Section III. TOOL AND TEST EQUIPMENT REQUIREMENTS
FOR
BOAT, BRIDGE ERECTION, TWIN JET, ALUMINUM HULL,
MODELS USCSBMK1 AND USCSBMK2 - Continued**

TOOL OR TEST EQUIPMENT REF CODE	MAINTENANCE CATEGORY	NOMENCLATURE	NATIONAL NATO STOCK NUMBER	TOOL NUMBER
20	H	Adapter, Camshaft Bearing Remove and Installer	5120-01-122-2953	FSCM K0598 PN 21-022-51
21	H	Installer, Oil Seat; Crankshaft Rear	5120-01-123-0132	FSCM K0598 PN 21-506
22	D	Remover, Valve Guide Delivery; Injection Pump	5120-00-089-7384	FSCM K0598 PN CT9022
23	D	Remover, Bearing; Injection Pump	5120-01-122-2952	FSCM K0598 PN CT9056
24	D	Installer, Bearing Injection Pump	5120-01-122-2951	FSCM K0598 PN CT9051
25	D	Gauge, Camshaft End Float; Injection Pump	5120-01-123-2543	FSCM K0598 PN CT9917
26	D	Adapter, Camshaft End Float; Injection Pump	5120-01-122-2959	FSCM K0598 PN CT901 7-1
27	D	Extractor, Less Jaws: Injection Pump	5120-01-133-4333	FSCM 31147 PN ST 190
28	D	Jaws, Jet; Extractor	5120-01-133-4334	FSCM 31147 PN ST 191
29	D	Jaws, Jet; Extractor	5120-01-133-4335	FSCM 31147 PN ST 192
30	D	Tester, Fuel Injector Pump	2090-01-154-7083	FSCM 31147 PN HA 1130
31	F	Tester, Compression Diesel Engine	4910-01-131-7773	FSCM 31147 PN 99-800
32	O	Shop Equipment, Organization Repair, Light Truck Mtd.	4940-01-928-2672	FSCM PN T 13132
33	O	Socket 7 mm 3/8" Drive	5120-01-112-8311	FSCM 55719 PN FSM71
34	O	Wrench Combination 7 mm	5120-01-112-286	FSCM 55719 PN OXIM7
35	O	Wrench, Open End 2-1/2"		FSCM 03914 PN 28-080
38	O	Wrench, Drum Nut		FSCM 63437 PN CPD

**Section IV. REMARKS
FOR
BOAT, BRIDGE ERECTION, TWIN JET, ALUMINUM HULL,
MODELS USCSBMK1 AND USCSBMK2**

REFERENCE CODE	REMARKS
A	Repair by straightening and welding.
B	Replace only the diaphragm inside valve.
C	Compression test only.
D	See individual component service time to perform maintenance function.
E	See individual component repair time to perform maintenance function.
F	Per one item removed from engine.
G	Requires oil to be drained.
H	Unit removed from boat.
I	MK1 only.
J	MK2 only.
K	Replace anode.
L	Repair by replacement of defective parts.

APPENDIX C

EXPENDABLE SUPPLIES AND MATERIALS LIST

Section I. INTRODUCTION

C-1. SCOPE

This appendix lists expendable supplies and materials you will need to operate and maintain the boat. These items are authorized to you by CTA 50-970, Expendable Items (Except Medical, Class V, Repair Parts, and Heraldic Items).

C-2. EXPLANATION OF COLUMNS

a. Column (1) - Item Number. This number is assigned to the entry in the listing and is referenced in the narrative instructions to identify the material (e.g., 'Use cleaning compound, item 5, App. C").

b. Column (2) - Level. This column identifies the lowest level of maintenance that requires the listed item. (enter as applicable)

C - Operator/Crew

O - Unit Maintenance

F - Direct Support Maintenance

H - General Support Maintenance

c. Column (3) - National Stock Number. This is the National stock number assigned to the item; use it to request or requisition the item.

d. Column (4) - Description. Indicates the Federal item name and, if required, a description to identify the item. The last line for each item indicates the Commercial and Government Entity Code (CAGEC) in parentheses followed by the part number.

e. Column (5) - Unit of Measure (U/M). Indicates the measure used in performing the actual maintenance function. This measure is expressed by a two-character alphabetical abbreviation (e.g., ea, in, pr). If the unit of measure differs from the unit of issue, requisition the lowest unit of issue that will satisfy your requirements.

Section II. EXPENDABLE SUPPLIES AND MATERIALS LIST

(1) ITEM NUMBER	(2) ITEM	(3) NATIONAL STOCK NUMBER	(4) DESCRIPTION	(5) (U/M)
1	C	9150-00-190-0907	GREASE, AUTOMOTIVE AND ARTILLERY (GAA), (81349) MIL-G-10924	CN
2	O	8030-00-889-3535	TAPE, ANTISEIZE, SIZE 1/2' X 260" (18876) 11072502	RO
3	O	8330-00-538-5212	SEALANT, SILICONE (71964) 732 RTV	TB
4	O	8305-00-267-3015	CLOTH, COTTON, CHEESE (81348) CCCC40	YD
5	O	7930-00-249-8036	DETERGENT, GENERAL PURPOSE (81348) P-D-220	
6	C	9150-00-186-6681	OIL, ENGINE, OE/HDO-30 MIL-L-2104	QT
7	C	9150-00-177-3988	OIL, ENGINE, OE/HDO-10 MIL-L-2104	QT
8	C	9140-00-286-5296	FUEL, DIESEL, DF-2, VV-F-800 (81348) 5 GALLON DRUM	GA
9	O		ANTIFREEZE, ETHYLENE GLYCOL INHIBITED, HEAVY DUTY, SINGLE PACKAGE, MIL-A-46153	GA
10	O	6850-00-274-5421	DRY CLEANING SOLVENT, P-D-680, TYPE II (81346) 5 GALLON DRUM	GA
11	O	7510-00-285-6403	TAPE, PSA, CELLULOSE, BLACK (81349) MIL-T-40620	RO
12	O		WIRE TIES	EA
13	O		INSULATING PLASTIC SPRAY PAINT	CN
14	O		ZINC CHROMATE PASTE	CN
15	O	5350-00-271-5946	STEEL WOOL, FF-VV-1825	RO
16	O		BAKING SODA (SODIUM BICARBONATE)	BX
17	O	4010-01-206-8627	WIRE, SAFETY, 0.032 NOM WIRE DIA CRES (84256)	LB
18	O	8030-00-543-4384	COMPOUND, SEALING, THREAD AND GASKET (61349) MIL-S-7916	LB
19	O	5940-00-143-4794	LUG CRIMP TYPE TERMINAL MS 25036-112	EA
20	O	9320-01-165-0861	RUBBER, SHEET, .062 STK ASTM D2000 1.00 in. wide M3BC617A14C12E034	RO
21	O	8040-00-221-3811	ADHESIVE, RUBBER BASE, GENERAL PURPOSE, TYPE II, MMM-A-1617	CN
22	O		SEALANT, COMPOUND, MIL-S-45180D	TB

APPENDIX D

ILLUSTRATED LIST OF MANUFACTURED ITEMS

INTRODUCTION

This appendix includes complete instructions for making items authorized to be manufactured or fabricated at organizational maintenance level.

A part number index in alphanumeric order is provided for cross-referencing the part number of the item to be manufactured to the figure which covers fabrication criteria.

All bulk materials needed for manufacture of an item are listed in tabular form for each illustration.

MANUFACTURE ITEMS PART NUMBER INDEX

D-1 Bilge Pump Nut Removal Tool

D-2 Scupper Drain Removal Tool

MANUFACTURED ITEMS ILLUSTRATIONS

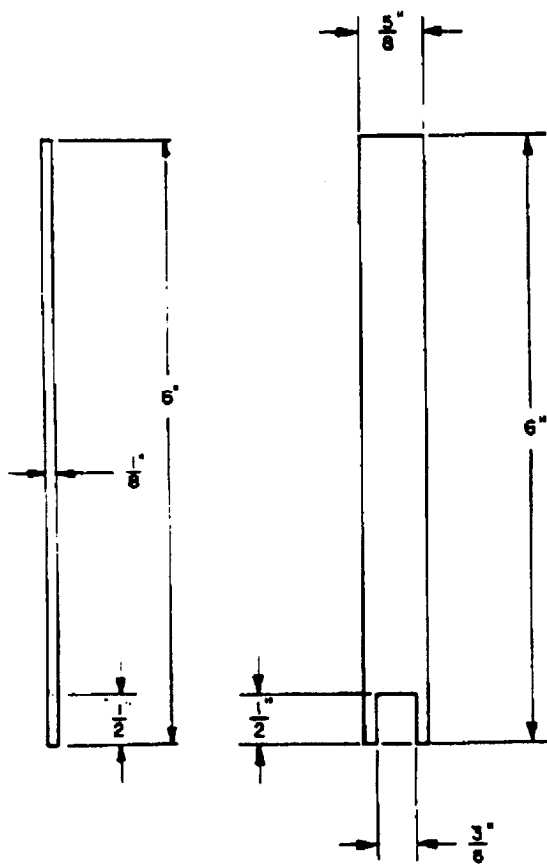

Bilge Pump Nut Removal Tool

Figure D-1

Low Carbon Steel Flat Bar
5/8" wide x 6" long x 1/8" thick

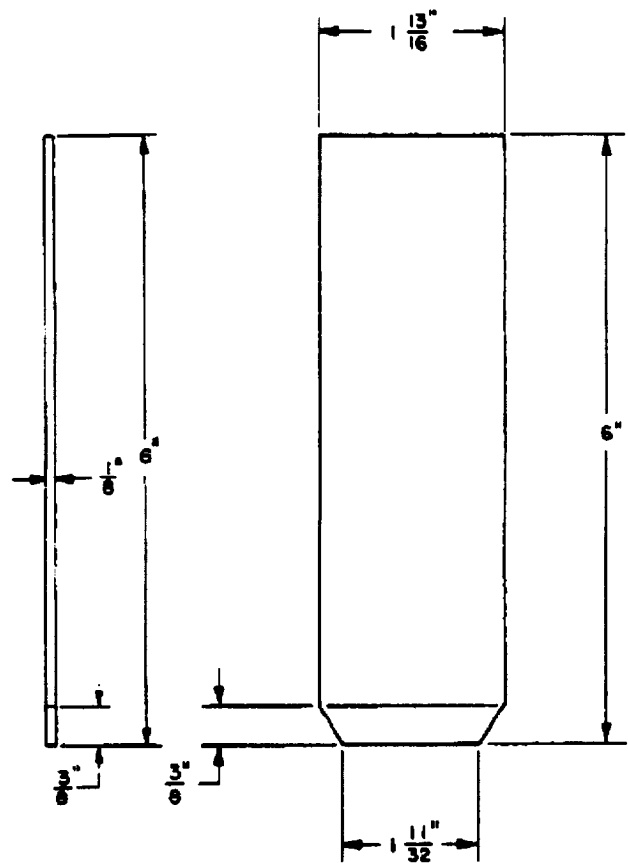

Scupper Drain Removal Tool

Figure D-2

Low Carbon Steel Flat Bar
2" wide x 6" long x 1/8" thick

GLOSSARY

Section I. ABBREVIATIONS

cc cubic centimeters
d c direct current
rpm revolutions per minute

Section II. DEFINITION OF UNUSUAL TERMS

Aft - At, near or toward rear of boat.

Berth - Place at dock where boat is tied up or anchored.

Bow - Front of boat.

Capstan - Manually rotated vertical cylinder for winding rope or cable.

Forward - At or toward front of boat.

Gearbox - Transmission.

Hydrojet - Water jet propulsion system.

NATO - North Atlantic Treaty Organization

Port - Left side of boat looking toward bow.

Raw Water - River water.

Rub Rail - Rubber bumper strip around boat hull.

Scoop - Moveable metal cover that directs water stream that comes from jets.

Sedimenter - Fuel strainer and water collector.

Starboard - Right side of boat looking toward bow.

Stem - Rear of boat.

Tachgenerator - Low voltage generator whose output indicates engine rpm.

Thermostart Unit - A combined fuel jet and glow plug used to pre-heat air going into intake manifold.

Transom - Stem structural member of boat.

Vdc - Volts direct current.

ALPHABETICAL INDEX

Subject, Page

A

Access Hatches Opening and Securing, 3-340
 Aft Cleat Replacement, 3-348
 Aft Cockpit Replacement, 3-48
 Air Filter and Silencer Service/Replacement, 3-282
 Air-Exhaust System, 1-23
 Alternator and Voltage Regulator Test, 3-198
 Alternator Replacement, 3-200
 Anchor Light Assembly Replacement (MK2), 3-206
 Automatic Fire Extinguisher Replacement, 3-313

B

Battery Cables Replacement, 3-194
 Battery Hatch, Hinges, and Support Brace Replacement,
 3-41
 Battery Replacement, 3-192
 Battery Testing, 3-189
 Blocking Diode Replacement, 3-235
 Blocking Diode Test, 3-233
 Boat Hook Holder Replacement, 3-350
 Buoyancy Material Removal and Installation, 3-321

C

Cab Assembly Repair, 3-11
 Cab Assembly Replacement, 3-13
 Capabilities and Features, 1-1
 Capstan Assembly Replacement, 3-25
 Capstan Assembly Replacement (MK2 and Retrofitted

 Capstan Assembly Servicing 3-23
 Capstan Assembly Servicing (MK2 and Retrofitted MK1),

 Common Tools and Equipment, 2-1
 Component Maintenance Instructions, 3-1
 Cooling System 3-1
 Electrical System, 3-2

Subject, Page

Engine Lubrication, 3-2
 Engines, 3-1
 Fuel System, 3-2
 Other Major Items, 3-2
 Control Box Cover Removal/Installation, 3-237
 Control Box Test, 3-239
 Control Cable and Linkage Adjustment (Transmission and
 Engine), 3-76
 Crankshaft Pulley Replacement, 3-274

D

Detailed Procedure General Information, 2-35
 Difference Between Models, 1-12
 Drain and Refill Fresh Water Cooling System (MK1),

 Drain and Refill Primary and Secondary Cooling Systems
 (MK2), 3-149
 Drive Shaft Assembly Repair, 3-301
 Drive Shaft Replacement, 3-299

E

Electric Bilge Pump Assembly Repair, 3-306
 Electric Bilge Pumps Replacement, 3-302
 Electric System, 1-25
 Electrical Leads, Cable and Connectors Inspection,
 Repair and Replacement, 3-227
 Emergency Link Solenoid Test and Replacement, 3-229
 Engine Alarm Mute Switch Replacement, 3-105
 Engine Audible Alarm Replacement, 3-127
 Engine Breather Water Trap Assembly Replacement,
 3-280
 Engine Breathing System, 1-28
 Engine Circuit Fuse Test, 3-248
 Engine Fuel Shutoff Valve and Diaphragm Replacement,
 3-131
 Engine Hatch Cover, Hinges, and Support Brace
 Replacement, 3-43
 Engine Hour Meter Replacement, 3-242
 Engine Hour Meter Test, 3-241
 Engine Oil Cooler Repair, 3-162

ALPHABETICAL INDEX - Continued

Subject, Page

E (con't)

Engine Oil Cooler Replacement (Port or Starboard),
3-160

Engine Oil Filter Replacement, 3-164

Engine Oil Replacement, 3-284

Engine or Transmission Control Head Assembly Repair,
3-62

Engine or Transmission Control Head Assembly
Replacement, 3-64

Engine Thermostat Replacement (Port or Starboard),
3-158

Engine Throttle Cable Replacement, 3-80

Engine V-Belt Replacement, 3-250

Engine Valve Cover Removal/Installation, 3-262

Engine Valve Tappets Adjustment, 3-272

Equipment Data, 1-7

Equipment Description, 1-1

Exhaust Flexible Bellows Replacement (MK1) - Port and
Starboard, 3-143

Exhaust Flexible Bellows Replacement (MK2) - Port and
Starboard, 3-145

Exhaust Manifold Replacement, 3-255

Expendable Supplies and Materials, C-1

F

Fast Fuse Replacement, 3-249

Fast Fuse Test, 3-247

Fendering (Rubber Rub Rail) Replacement, 3-318

Fire Extinguishing System, 1-23

Flywheel and Starter Ring Gear Inspection, 3-276

Forward Cockpit and Control Console, Location and
Description, 1-5

Forward Electric Bilge Pump Replacement (MK2 ONLY),

Fresh (MK1) or Primary (MK2) Water Pump
Replacement (Port and Standard), 3-151

Fuel Filters Replacement, 3-138

Fuel Level Sending Unit Replacement, 3-222

Index 2

Subject, Page

Fuel Lift Pump Assembly Replacement, 3-140

Fuel Master Shutoff Valve Replacement, 3-133

Fuel System, 1-20

Fuel System Bleeding, 3-142

Fuel Tubing Replacement, 3-129

Fuel Water Separator Replacement, 3-136

Fuel Water Separator Servicing, 3-135

G

Glossary, Glossary-1

H

Hand Bilge Pump Assembly Repair (MK1), 3-311

Hand Bilge Pump Assembly Replacement (MK1), 3-309

Hand Fire Extinguisher Replacement, 3-315

Header Tank Replacement (MK1 and MK2), 3-156

Header Tank/Heat Exchanger Repair (MK1), 3-154

Heat/Start and Toggle Switch Test, 3-102

Horn Replacement, 3-125

Hydrojet Hatch Cover, Hinges, and Support Brace
Replacement, 3-46

Hydrojet Tail Cone Anodes Replacement, 3-296

I

Illustrated List of Manufactured Items, D-1

Index, Maintenance Procedure Instructions,
Organizational, 3-3

Injector Line and Fitting Replacement, 3-260

Injector Replacement, 3-268

Inspection Light Replacement, 3-214

Intake Strainer (MK1) Replacement, 3-185

Intercooler Repair (Port and Starboard), 3-177

Intercooler Replacement (Port and Starboard), 3-179

J

Junction Box Unit X1 Replacement, 3-115

ALPHABETICAL INDEX - Continued

Subject, Page

Subject, Page

J (con't)

Junction Box Unit #2 Replacement (MK2 and MK1),
3-119

K

Keel Anodes Replacement, 3-316

Keel Cooler (Front and Rear) Replacement (MK2),
3-166

L

Linkage Scoop Control Assembly Adjustment, 3-68

Location and Description of Major Components, 1-3

Location and Description of Forward Cockpit and Control
Console, 1-5

M

Maintenance Allocation Chart, B-1

Maintenance Forms and Records, 1-1

Maintenance Procedure Instructions Index, Unit, 3-3

Maintenance Procedures

Assembly, 2-34

Cleaning, 2-34

Disassembly, 2-34

Inspection, 2-34

Repair, 2-34

Major Components, Location and Description, 1-3

Map Light Replacement (MK1 only), 3-215

Mast Repair, 3-7

Mast Replacement, 3-9

Master Switch Replacement, 3-217

MK1 Engine Cooling System, 1-17

MK2 Engine Cooling System, 1-17

Multimeter - Set Up and Use to Test Electrical System,
3-338

O

Oil and Water Sending Units Replacement, 3-219

Oil Reservoir Repair, 3-298

Out of Water Engine Operation (MK1), 3-344

Out of Water Engine Operation (MK2), 3-346

P

Piping, Hoses, and Fittings Replacement (Cooling
System), 3-147

Preventive Maintenance Checks and Services (PMCS),

Propulsion System, 1-14

Purpose of Bridge Erection Boat, 1-1

Pushknees Repair (MK1), 3-35

Pushknees Repair (MK2), 3-39

Pushknees Replacement (MK1), 3-37

R

References, A-1

Remote Cooler Inspection and Replacement (MK1 -
Port and Starboard), 3-168

Repair Parts 2-1

Reporting Equipment Improvement Recommendations,
1-1

Rocker Arms, Shaft and Push Rods Inspection and
Replacement, 3-264

S

Scoop Control Head Assembly Repair, 3-56

Scoop Control Head Assembly Replacement, 3-58

Scoop Control Replacement (Port and Starboard), 3-71

Scupper Drains (Aft Cockpit) Servicing and Replacement,
3-54

Scupper Drains (Forward Cockpit) Servicing and
Replacement, 3-52

Searchlight Replacement, 3-212

ALPHABETICAL INDEX - Continued

Subject, Page

S (con't)

Service Upon Receipt, 2-1
Slave Starting, 3-186
Solenoid Test, 3-245
Special Tools, TMDE and Support Equipment, 2-1
Starter Replacement (Port or Starboard), 3-253
Starter Test, 3-252
Steering Assembly Brush Replacement, 3-294
Steering Unit Hatch Cover and Hinges Replacement, 3-50
Sump Pump Replacement, 3-278
Surge Protection Unit Test, 3-243
Switch Panel Unit #1 Replacement (MK2 and MK1), 3-107
Switch Panel Unit #1 to Junction Box Unit #1 Wiring Harness (MK2 and MK1), 3-123
Switch Panel Unit #2 Replacement (MK2 and MK1), 3-111

T

Tachometer Sending Unit Assembly Inspection and Repair, 3-226
Tachometer Sending Unit Assembly Replacement, 3-224
Technical Principles of Operation, 1-14
Thermostat Unit Replacement, 3-231
Tow Hook (MK2) Replacement, 3-31
Tow Hook Assembly Repair (Spring and Lanyard Replacement - MK2 and Retrofitted MK1), 3-33
Towing, Steaming, and Navigation Light Assembly Replacement (MK1), 3-208

Subject, Page

Towing, Steaming, and Navigation Light Assembly Replacement (MK2), 3-210
Transmission Cable Replacement, 3-78
Transmission Inspection, 3-292
Transmission Oil Cooler Inspection and Repair - MK1 and MK2, 3-181
Transmission Oil Cooler Replacement - MK1 and MK2, 3-183
Transmission Oil Hoses and Fittings Replacement, 3-288
Transmission Oil Starter Inspection, Servicing and Replacement, 3-286
Troubleshooting, Unit, 2-17
Turbocharger Replacement, 3-257

W

Warranty Information, 1-1
Water Pump Inspection (Port or Starboard Engine)
MK1 - cooling system Pump, 3-170
MK1 - Raw Water Pump, 3-170
MK2 - Secondary Water Pump, 3-170
Water Pump Repair
MK1 - Cooling System Pump, 3-173
MK1 - Raw Water Pump, 3-173
MK2 - Secondary Water Pump, 3-173
Water Pump Replacement (Port or Starboard Engine)
MK1 - Cooling System Pump, 3-175
MK1 - Raw Water Pump, 3-175
MK2 - Secondary Water Pump, 3-175
Windshield Wiper Blade Replacement, 3-15
Windshield Wiper Drive Unit Repair, 3-19
Windshield Wiper Drive Unit Replacement, 3-21
Windshield Wiper Motor Replacement, 3-17

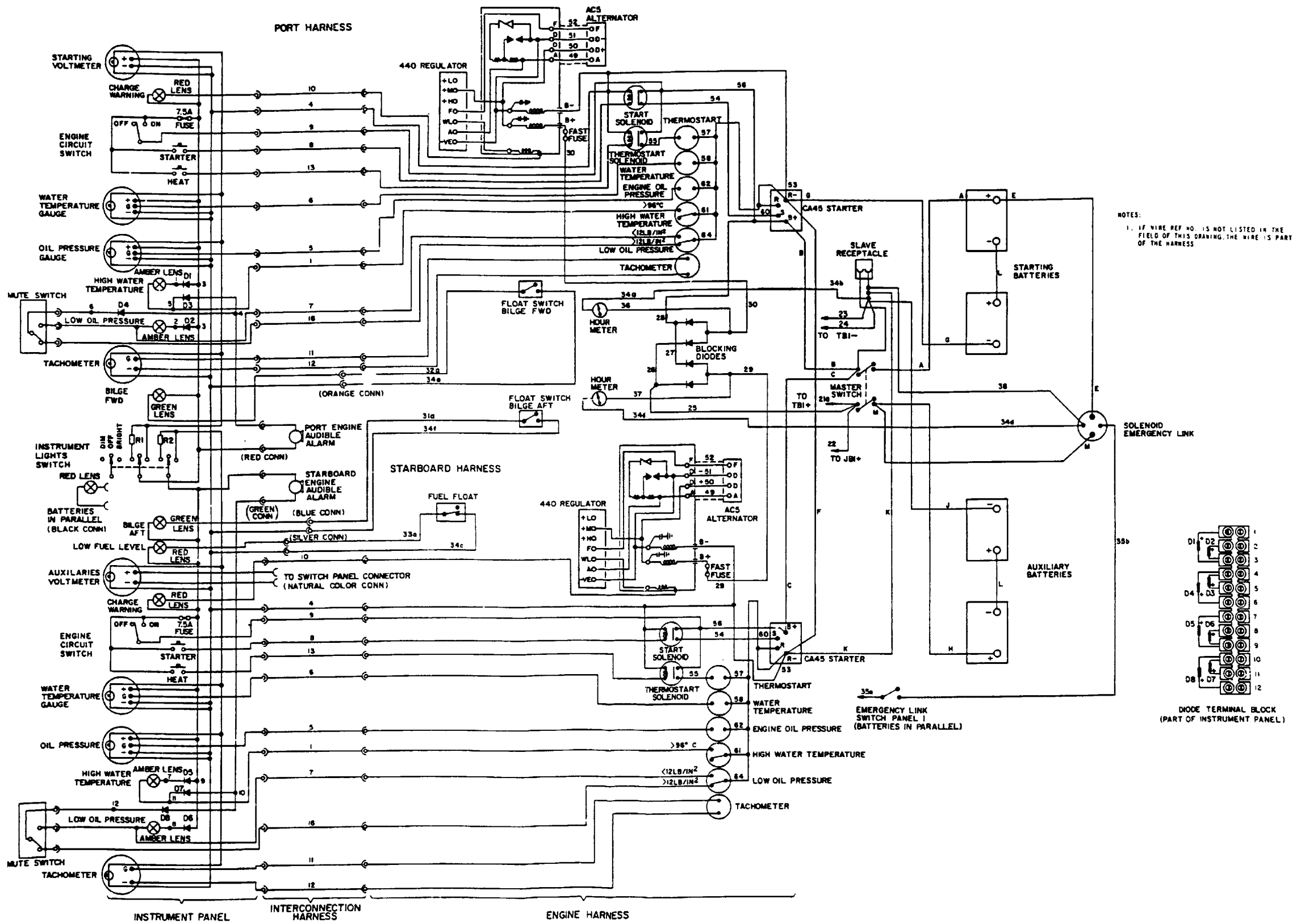

NOTES:
 1. IF WIRE REF. NO. IS NOT LISTED IN THE FIELD OF THIS DRAWING, THE WIRE IS PART OF THE HARNESS.

WIRE INDEX 1

REF NO.	COLOR	FUNCTION	WIRE SIZE (AWG)
1	YELLOW/BLUE	HIGH WATER TEMP LIGHT	16
2	WHITE/VIOLET	SPARE	16
3	RED/WHITE	SPARE	14
4	BLACK	NEGATIVE	14
5	YELLOW	ENG OIL PRESSURE	16
6	WHITE/BLUE	WATER TEMP	16
7	YELLOW/RED	LOW OIL PRESSURE LIGHT	16
8	GREEN	START	14
9	RED	POSITIVE	14
10	VIOLET	CHARGE WARNING LIGHT	16
11	BLACK/BROWN	TACHOMETER	16
12	BLACK/BLUE	TACHOMETER	16
13	WHITE	THERMO START	14
14	RED/BLACK	SPARE	14
15	BLACK/WHITE	SPARE	16
16	BLACK/YELLOW	LOW OPRS/WATER HTM ALARM	16
25	RED	CHARGING CIRCUITS	10
26	BROWN/WHITE	CHARGING CIRCUITS	10
27	YELLOW	CHARGING CIRCUITS	10
28	BROWN/YELLOW	CHARGING CIRCUITS	10
29	WHITE/RED	CHARGING CIRCUITS	10
30	WHITE/RED	CHARGING CIRCUITS	10
31	PINK	AFT BILGE FLOAT LIGHT	16
32	WHITE	AMID BILGE FLOAT LIGHT	16
33	PURPLE/RED	FUEL LEVEL FLOAT LIGHT	16
35	BROWN	+ VE EMERGENCY LINK	14

INTERCONNECTION HARNESS
AND ENGINE HARNESS

WIRE INDEX 1 (CONTINUED)

REF NO.	COLOR	FUNCTION	WIRE SIZE (AWG)
36	PURPLE/WHITE	HOUR METER	16
37	BLUE/GREEN	HOUR METER	16
38	BLACK	- VE EMERGENCY LINK	14
49	BLUE	ALTERNATOR	16
50	BROWN	ALTERNATOR + OUT	12
51	BLACK	ALTERNATOR - OUT	12
52	GREEN	ALTERNATOR	16
53	BLACK	STARTER NEGATIVE STUD	12
54	GREEN/BROWN	STARTER ENERGIZE	14
55	WHITE	THERMAL START + POSITIVE	14
56	RED	STARTER + POSITIVE	12
57	BLACK	THERMAL START NEGATIVE	16
58	BLACK	NEGATIVE	16
59	BLACK	SPARE NEGATIVE	16
60	BLACK	STARTER NEGATIVE	16
61	BLACK	HIGH WATER TEMP. WARN	14
		NEGATIVE	
62	BLACK	OIL PRESSURE SENSOR	16
		NEGATIVE	
63	BLACK	SPARE NEGATIVE	16
64	BLACK	LOW OIL PRESSURE	16
		WARNING NEGATIVE	
68	RED	AUX VOLTMETER	16

WIRE INDEX 2

REF NO.	COLOR	FUNCTION	WIRE SIZE (AWG)
17	YELLOW/BROWN	WIPER PORT	16
18	GREEN/RED	WIPER STBD	16
19	GREEN	AFT BILGE PUMP	12
20	WHITE	FWD BILGE PUMP	12
21	RED	+ VE AUX CIRCUITS	8
22	RED	+ VE AUX CIRCUITS	8
23	BLACK	- VE AUX CIRCUITS	8
24	BLACK	- VE AUX CIRCUITS	8
34	BLACK	NEGATIVE	16
35	BROWN	+ VE EMERGENCY LINK	14
39	BLUE	NAV. LIGHTS	16
40	BROWN	TOWING LIGHTS	16
41	GREEN	ANCHOR LIGHT	16
42	GREEN/BROWN	SEARCH LIGHT	16
43	RED	INSPECTION LIGHT	16
44	BLACK	NEGATIVE	14
46	GREEN/YELLOW	HORN	16
47	BLACK	NEGATIVE	12
67	BLACK	JUMBER	8

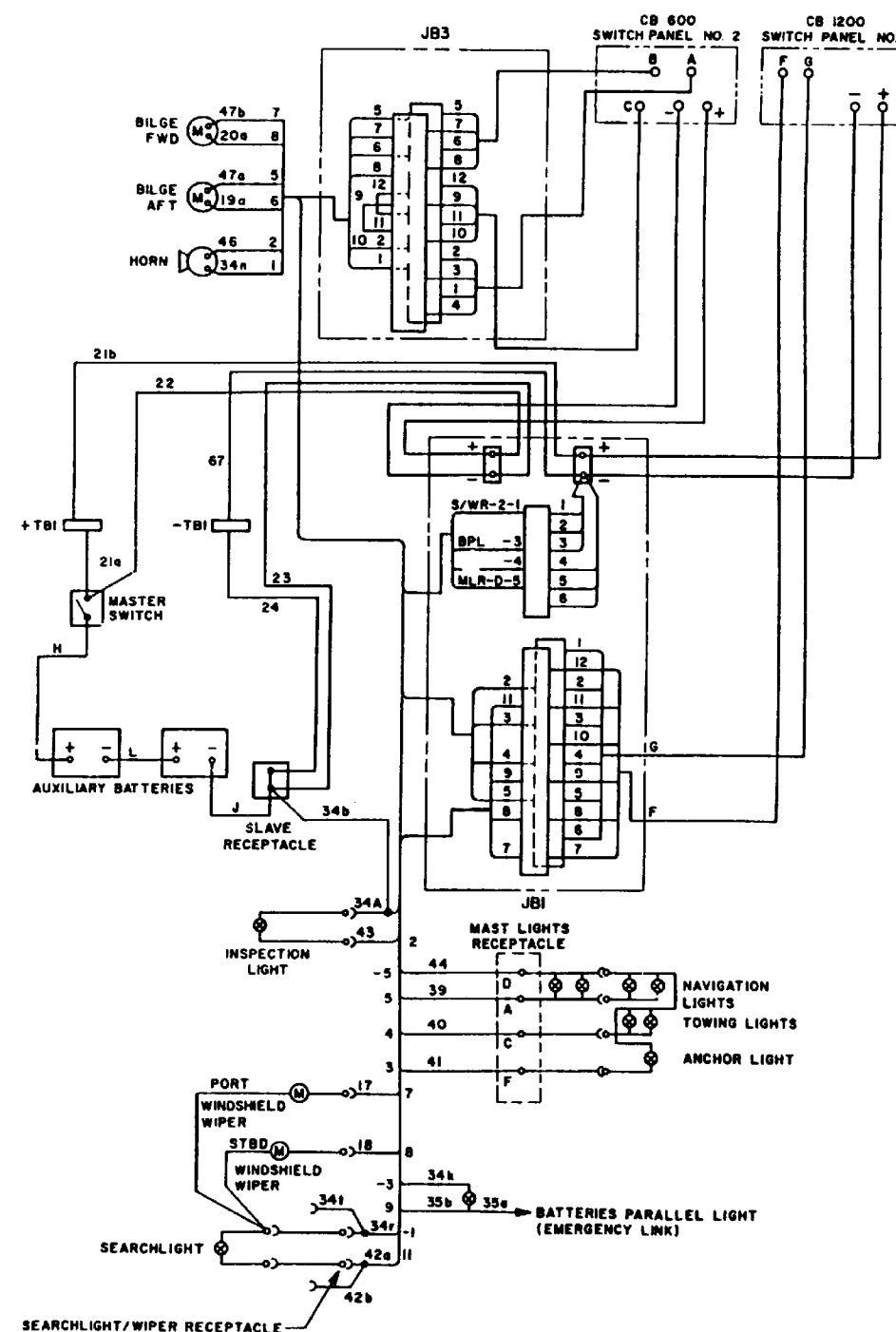

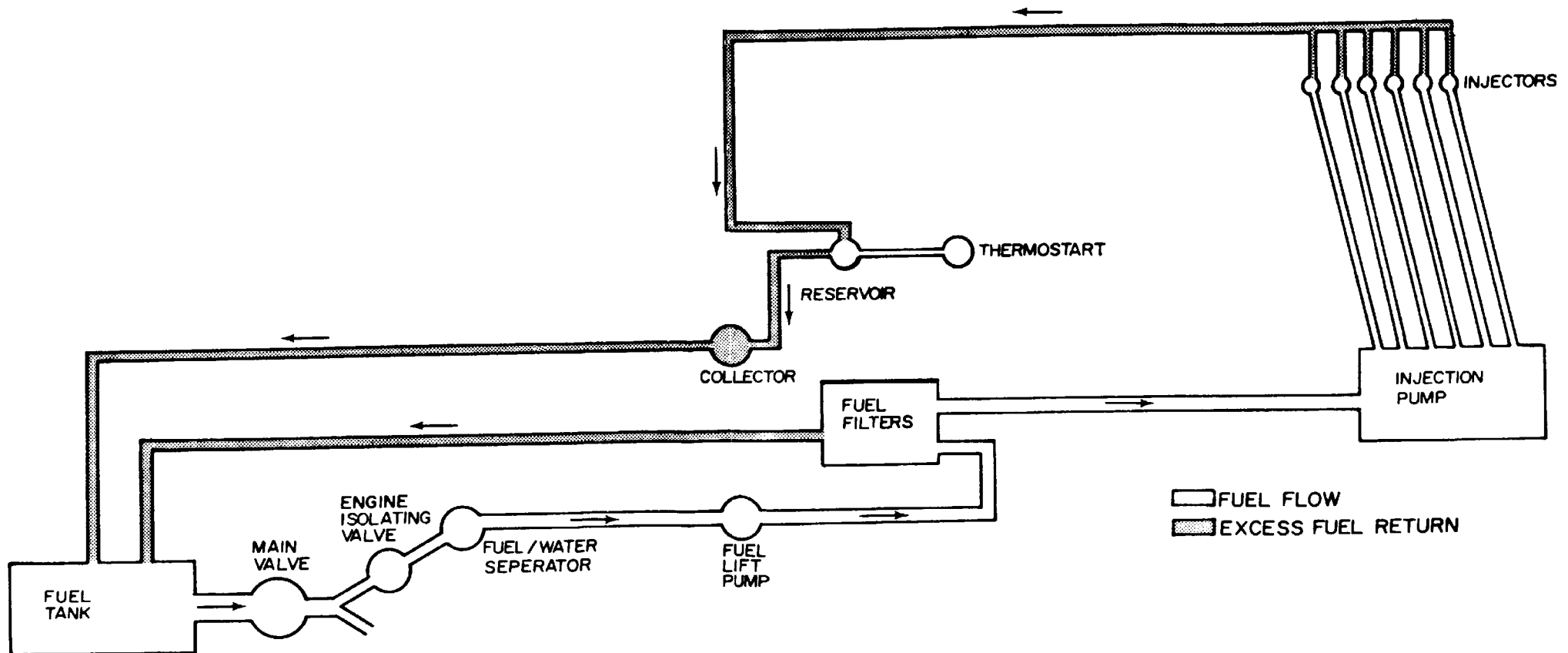

FO 2. FUEL SYSTEM DIAGRAM FP-7/(FP-8 blank)

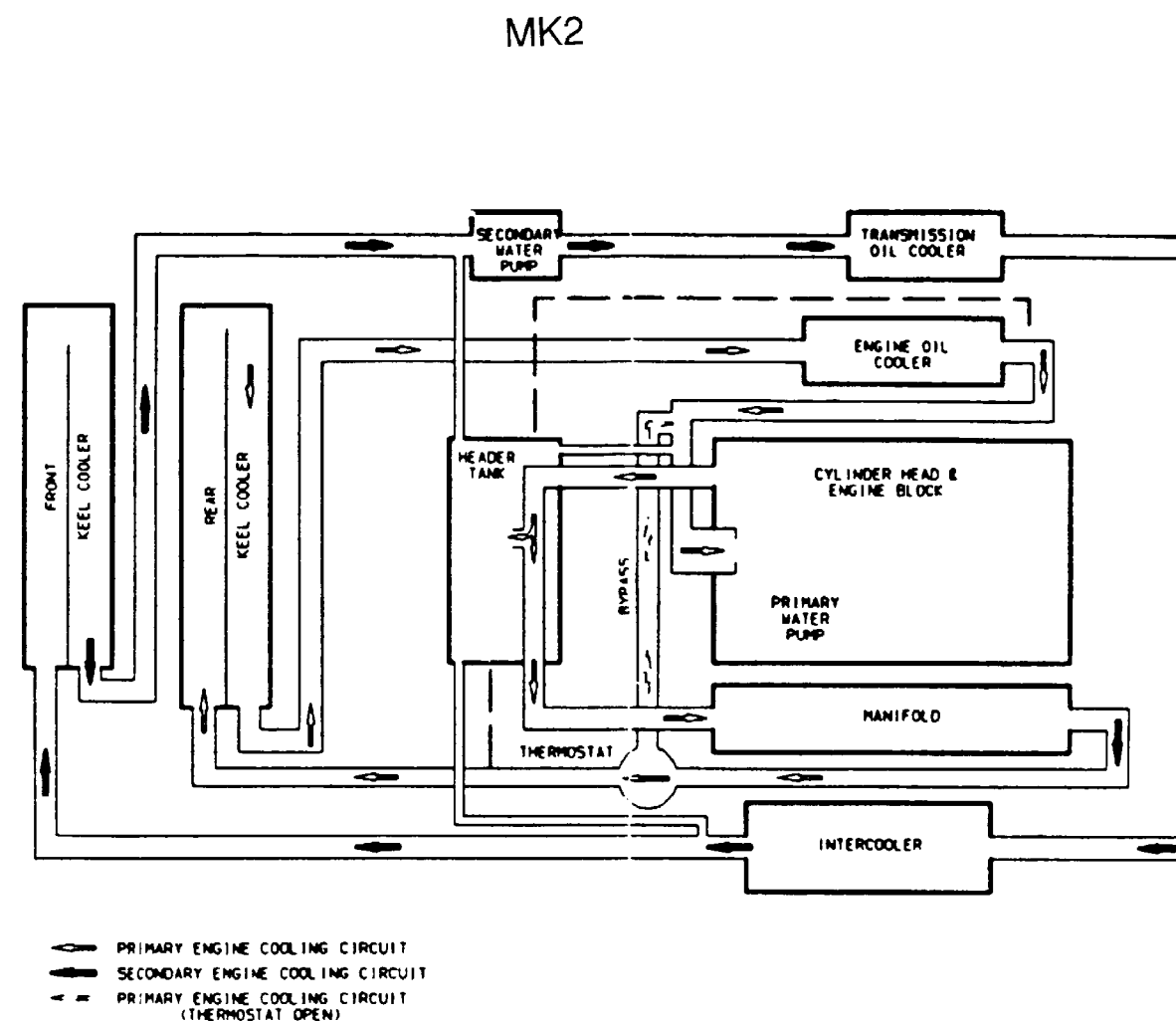
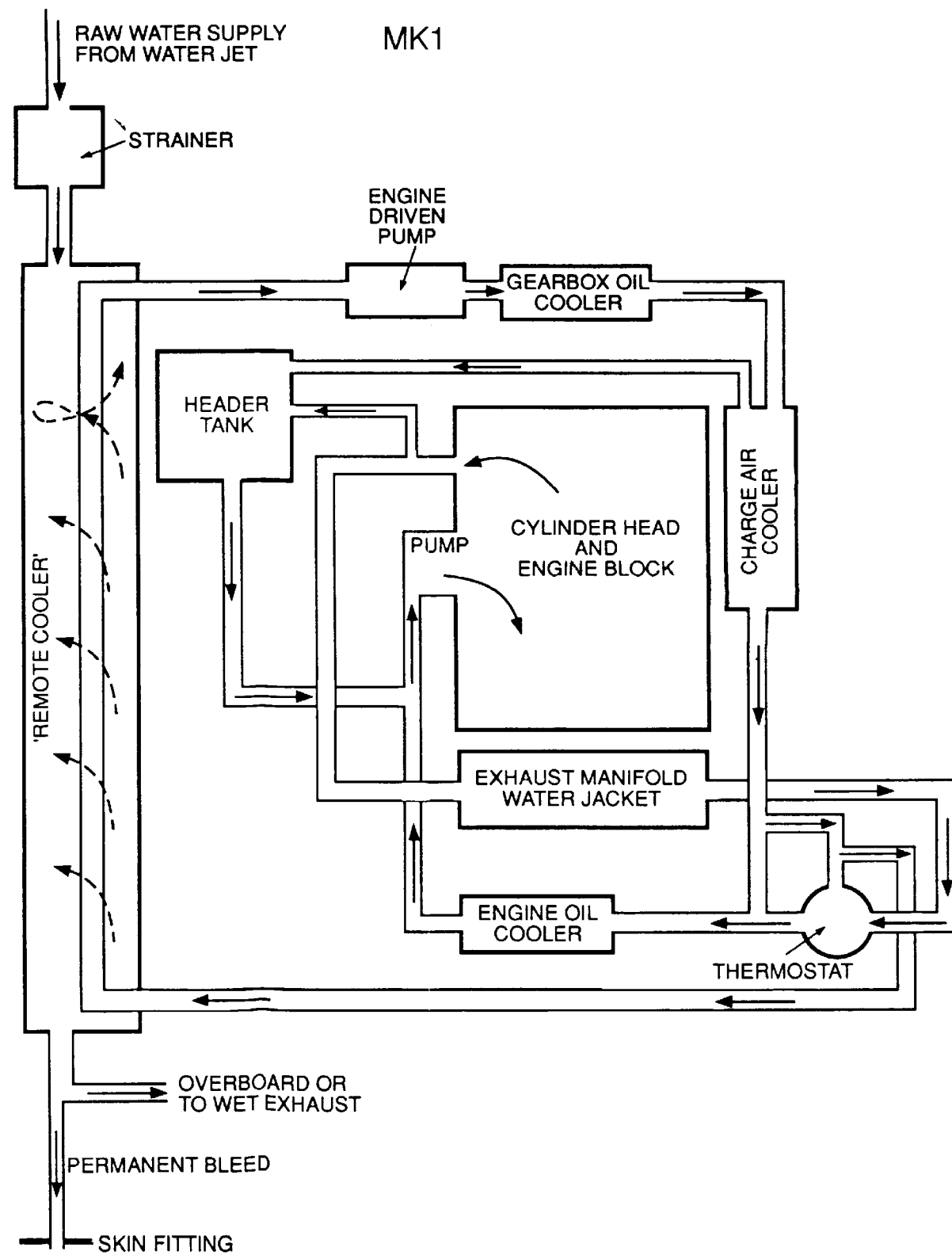

By Order of the Secretaries of the Army and Navy (Including the Marine Corps):

Official:

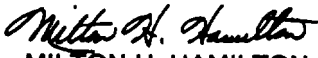
MILTON H. HAMILTON
Administrative Assistant to the
Secretary of the Army
06688

GORDON R. SULLIVAN
General, United States Army
Chief of Staff

DAVID E. BOTTORFF
Rear Admiral, CEC, US Navy
Commander
Navy Facilities Engineering
Command

D. R. BLOOMER
Colonel, USMC
Director, Program Support
Marine Corps Systems Command

DISTRIBUTION:

To be distributed in accordance with DA Form 12-25-E, block no. 0263, requirements for
TM 5-1940-277-20.

These are the instructions for sending an electronic 2028

The following format must be used if submitting an electronic 2028. The subject line must be exactly the same and all fields must be included; however only the following fields are mandatory: 1, 3, 4, 5, 6, 7, 8, 9, 10, 13, 15, 16, 17, and 27.

From: "Whomever" <whomever@avma27.army.mil>
To: mpmt%avma28@st-louis-emh7.army.mil

Subject: DA Form 2028

1. **From:** Joe Smith
2. Unit: home
3. **Address:** 4300 Park
4. **City:** Hometown
5. **St:** MO
6. **Zip:** 77777
7. **Date Sent:** 19-OCT-93
8. **Pub no:** 55-2840-229-23
9. **Pub Title:** TM
10. **Publication Date:** 04-JUL-85
11. Change Number: 7
12. Submitter Rank: MSG
13. **Submitter FName:** Joe
14. Submitter MName: T
15. **Submitter LName:** Smith
16. **Submitter Phone:** 123-123-1234
17. **Problem:** 1
18. Page: 2
19. Paragraph: 3
20. Line: 4
21. NSN: 5
22. Reference: 6
23. Figure: 7
24. Table: 8
25. Item: 9
26. Total: 123
27. **Text:**

This is the text for the problem below line 27.

SOMETHING WRONG WITH THIS PUBLICATION?



THEN... JOT DOWN THE DOPE ABOUT IT ON THIS FORM. CAREFULLY TEAR IT OUT. FOLD IT AND DROP IT IN THE MAIL!

FROM (PRINT YOUR UNIT'S COMPLETE ADDRESS)
 CDR, 1st Br, 65th ADA
 ATTN: SP4 J. Brown
 Key West, FL 33040

DATE SENT
 10 Jun 79

PUBLICATION NUMBER
 TM 9-1430-550-34-1

PUBLICATION DATE
 7 Sep 72 .

PUBLICATION TITLE Unit of Radar Set
 AN/MPQ-50 Tested at the HFC

BE EXACT PIN-POINT WHERE IT IS

PAGE NO	PARA-GRAPH	FIGURE NO	TABLE NO
9-19		9-5	
21-2	step 1C	21-2	

IN THIS SPACE TELL WHAT IS WRONG AND WHAT SHOULD BE DONE ABOUT IT:

"B" Ready Relay K11 is shown with two #9 contacts. That contact which is wired to pin 8 of relay K16 should be changed to contact #10.

Reads: Multimeter B indicates 600 K ohms to 9000 K ohms.

Change to read: Multimeter B indicates 600 K ohms minimum.

Reason: Circuit being checked could measure infinity. Multimeter can read above 9000 K ohms and still be correct.

SAMPLE

PRINTED NAME GRADE OR TITLE AND TELEPHONE NUMBER

SP4 J.T. Brown, Jr.

SIGN HERE

SP4 James Brown, Jr.

TEAR ALONG PRIORITIZED LINE

RECOMMENDED CHANGES TO EQUIPMENT TECHNICAL PUBLICATIONS



THEN... JOT DOWN THE DOPE ABOUT IT ON THIS FORM. CAREFULLY TEAR IT OUT. FOLD IT AND DROP IT IN THE MAIL!

SOMETHING WRONG WITH THIS PUBLICATION?

FROM: (PRINT YOUR UNIT'S COMPLETE ADDRESS)

DATE SENT

PUBLICATION NUMBER

TM 5-1940-277-20

PUBLICATION DATE

29 APRIL 1994

PUBLICATION TITLE

BOAT, BRIDGE ERECTION, TWIN JET, ALUMINUM HULL

BE EXACT PIN-POINT WHERE IT IS

PAGE NO

PARA-GRAPH

FIGURE NO

TABLE NO

IN THIS SPACE TELL WHAT IS WRONG AND WHAT SHOULD BE DONE ABOUT IT:

PRINTED NAME GRADE OR TITLE AND TELEPHONE NUMBER

SIGN HERE

1 Nov 80

FILL IN YOUR
UNITS ADDRESS



FOLD BACK

DEPARTMENT OF THE ARMY

OFFICIAL BUSINESS

COMMANDER
U.S. ARMY AVIATION AND TROOP COMMAND
ATTN: AMSAT-I-MP
4300 GOODFELLOW BOULEVARD
ST. LOUIS, MO 63120-1798

TEAR ALONG PERFORATED LINE

The Metric System and Equivalents

Linear Measure

1 centimeter = 10 millimeters = .39 inch
 1 decimeter = 10 centimeters = 3.94 inches
 1 meter = 10 decimeters = 39.37 inches
 1 dekameter = 10 meters = 32.8 feet
 1 hectometer = 10 dekameters = 328.08 feet
 1 kilometer = 10 hectometers = 3,280.8 feet

Weights

1 centigram = 10 milligrams = .15 grain
 1 decigram = 10 centigrams = 1.54 grains
 1 gram = 10 decigrams = .035 ounce
 1 dekagram = 10 grams = .35 ounce
 1 hectogram = 10 dekagrams = 3.52 ounces
 1 kilogram = 10 hectograms = 2.2 pounds
 1 quintal = 100 kilograms = 220.46 pounds
 1 metric ton = 10 quintals = 1.1 short tons

Liquid Measure

1 centiliter = 10 milliliters = .34 fl. ounce
 1 deciliter = 10 centiliters = 3.38 fl. ounces
 1 liter = 10 deciliters = 33.81 fl. ounces
 1 dekaliter = 10 liters = 2.64 gallons
 1 hectoliter = 10 dekaliters = 26.42 gallons
 1 kiloliter = 10 hectoliters = 264.18 gallons

Square Measure

1 sq. centimeter = 100 sq. millimeters = .155 sq. inch
 1 sq. decimeter = 100 sq. centimeters = 15.5 sq. inches
 1 sq. meter (centare) = 100 sq. decimeters = 10.76 sq. feet
 1 sq. dekameter (are) = 100 sq. meters = 1,076.4 sq. feet
 1 sq. hectometer (hectare) = 100 sq. dekameters = 2.47 acres
 1 sq. kilometer = 100 sq. hectometers = .386 sq. mile -

Cubic Measure

1 cu. centimeter = 1000 cu. millimeters = .06 cu. inch
 1 cu. decimeter = 1000 cu. centimeters = 61.02 cu. inches
 1 cu. meter = 1000 cu. decimeters = 35.31 cu. feet

Approximate Conversion Factors

To change	To	Multiply by	To change	To	Multiply by
inches	centimeters	2.540	ounce-inches	newton-meters	.007062
feet	meters	.305	centimeters	inches	.394
yards	meters	.914	meters	feet	3.280
miles	kilometers	1.609	meters	yards	1.094
square inches	square centimeters	6.451	kilometers	miles	.621
square feet	square meters	.093	square centimeters	square inches	.155
square yards	square meters	.836	square meters	square feet	10.764
square miles	square kilometers	2.590	square meters	square yards	1.196
acres	square hectometers	.405	square kilometers	square miles	.386
cubic feet	cubic meters	.028	square hectometers	acres	2.471
cubic yards	cubic meters	.765	cubic meters	cubic feet	35.315
fluid ounces	milliliters	29.573	cubic meters	cubic yards	1.308
pints	liters	.473	milliliters	fluid ounces	.034
quarts	liters	.946	liters	pints	2.113
gallons	liters	3.785	liters	quarts	1.057
ounces	grams	28.349	liters	gallons	.264
pounds	kilograms	.454	grams	ounces	.035
short tons	metric tons	.907	kilograms	pounds	2.205
pound-foot	newton-meters	1.356	metric tons	short tons	1.102
pound-inches	newton-meters	.11296			

Temperature (Exact)

°F	Fahrenheit temperature	5/9 (after subtracting 32)	Celsius temperature	°C
----	------------------------	----------------------------	---------------------	----

PIN: 049931-000